



# Hardware User Guide

## Wolverine II AC with Remote IS System

Part No: MAN00087 Rev. B

## Document History

Hardware Reference Manual Document Number: MAN00087 Rev. B September 24, 2010:

Version	Date	Description	Author
A	2009.09.21	First version	J.B.
B	2010.03.30	Update Ethernet cable language Update branding	T.B.

## Copyright Notice

This document is copyrighted, 2010 by the Manufacturer. The information provided in this document has been carefully checked and is accurate at the time of publication. However, Computer Dynamics, Inc. (CDI) assumes no responsibility for any infringements of patents or other rights of third parties that may result from its use.

No part of this publication may be reproduced, stored in a retrieval system, or transmitted in any form or via any means without the prior written permission of the manufacturer. Furthermore, this publication and features described herein are subject to change without notice.

## Trademarks

All brand and product names used for identification in this document are trademarks or registered trademarks of their respective companies.

## Disclaimer

Computer Dynamics reserves the right to make changes, without notice, to any product, including circuits and/or software described or contained in this manual in order to improve design and/or performance. Computer Dynamics assumes no responsibility or liability for the use of the described product(s), conveys no license or title under any patent, copyright, or mask work rights to these products, and makes no representations or warranties that these products are free from patent, copyright, or mask work right infringement, unless otherwise specified. Applications that are described in this manual are for illustration purposes only. Computer Dynamics makes no representation or warranty that such application will be suitable for the specified use without further testing or modification.

## Warranty

Computer Dynamics warrants that each of its products will be free from material and workmanship defects for a period of one year from the invoice date. If the customer discovers a defect, Computer Dynamics will, at its option, repair or replace the defective product at no charge to the customer, provided it is returned during the warranty period of one year, with transportation charges prepaid. The returned product must be properly packaged in its original packaging to obtain warranty service.

# Warnings, Cautions, and Notes as Used in this Publication



Warning notices are used in this publication to emphasize that hazardous voltages, currents, temperatures, or other conditions that could cause personal injury exist in this equipment or may be associated with its use.

In situations where inattention could cause either personal injury or damage to equipment, a Warning notice is used.



Caution notices are used where equipment might be damaged if care is not taken.



Notes merely call attention to information that is especially significant to understanding and operating the equipment.

## Important Safety Precautions

### Warning



Always completely disconnect the power cord from your chassis whenever you work with the hardware. Do not make connections while the power is on. Sensitive electronic components can be damaged by sudden power surges. Only experienced electronics personnel should open the PC chassis.

### Caution



Always ground yourself to remove any static charge before touching the CPU card. Modern electronic devices are very sensitive to static electric charges. As a safety precaution, use a grounding wrist strap at all times. Place all electronic components in a static-dissipative surface or static-shielded bag when they are not in the chassis.

## Safety and Warranty



- Please read these safety instructions carefully.
- Please disconnect this equipment from any AC outlet before cleaning. Do not use liquid or spray detergents for cleaning, use a damp cloth.
- For pluggable equipment, the power outlet must be installed near the equipment and must be easily accessible.
- Put this equipment on a reliable surface during installation. Dropping it or letting it fall could cause damage.
- Make sure the voltage of the power source is correct before connecting the equipment to the power outlet.
- Position the power cord so that people cannot step on it. Do not place anything over the power cord.
- All cautions and warnings on the equipment should be noted.
- If the equipment is not used for a long time, disconnect it from the power source to avoid damage by transient over-voltage.
- Never pour any liquid into an opening. This could cause fire or electrical shock.
- Never open the equipment. For safety reasons, only qualified service personnel should open the equipment.
- If any of the following situations arises, get the equipment checked by service personnel:
  - The power cord or plug is damaged.
  - Liquid has penetrated into the equipment.
  - The equipment does not work well, or you cannot get it to work according to the user's manual.
  - The equipment has been dropped and damaged.
  - The equipment has obvious signs of breakage.

## Content of this Manual

This manual describes the features and operation of the following Wolverine industrial computers:

WOLVERINE II AC with Remote IS System – Main Enclosure containing 15.0" Industrial computer with Windows XP  
- Remote Enclosure containing Ethernet Intrinsic Safety Barrier

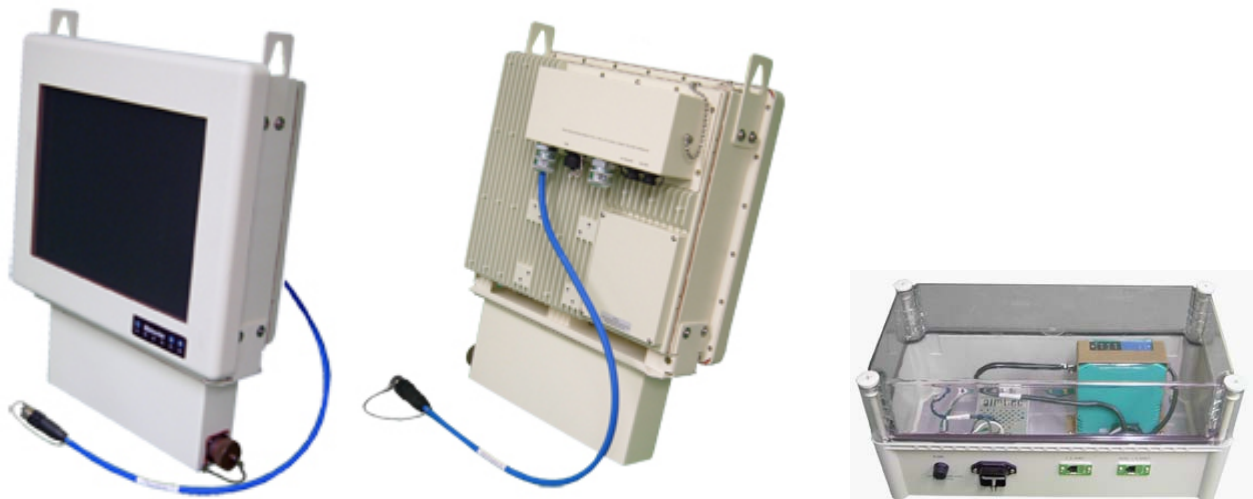

# Table of Contents

Informational Pages.....	ii
<b>1. Computer Features.....</b>	<b>1-1</b>
1.1. Feature Summary.....	1-2
1.1.1. Standard Features.....	1-2
1.1.2. Back I/O Plates.....	1-2
1.1.3. Gland Plate.....	1-3
1.1.4. Power Input.....	1-4
1.1.5. Standard I/O.....	1-4
1.1.6. Heaters.....	1-4
1.1.7. Front Overlay Keypad.....	1-4
<b>2. Hardware Installation.....</b>	<b>2-1</b>
2.1. Installation Guidelines – Main Enclosure.....	2-1
2.2. Installation Guidelines – Remote Enclosure.....	2-1
2.3. Warnings for Hazardous Area Approvals.....	2-3
2.4. Markings for Hazardous Area Approvals.....	2-4
<b>3. Connectors &amp; Cabling.....</b>	<b>3-1</b>
3.1. Power Input – Main Enclosure.....	3-1
3.2. Power Input – Remote Enclosure.....	3-1
3.3. Connector Layout.....	3-2
3.4. Printer Port LPT1.....	3-2
3.5. Serial Communication Ports.....	3-3
3.5.1. RS-485 Option.....	3-3
3.5.2. RS-422 Option.....	3-3
3.5.3. Shielding.....	3-4
3.6. USB Ports.....	3-4
3.7. VGA Port.....	3-4
3.8. Mouse & Keyboard Ports.....	3-4
3.9. Ethernet Interface.....	3-5
<b>4. System Operation.....</b>	<b>4-1</b>
4.1. Setup.....	4-1
4.1.1. Powering Up the Wolverine Industrial Computer.....	4-1
4.1.2. Powering Down the Wolverine Industrial Computer.....	4-1
4.2. System Peripherals.....	4-1
4.2.1. Removable Storage Media.....	4-1
4.3. External Keyboard and Mouse.....	4-3
4.4. Graphic System.....	4-3
4.5. Touch Screen.....	4-3
4.6. Touch Screen Driver for Windows.....	4-3
4.7. Communications.....	4-3
4.8. Heater Operation.....	4-4
4.9. Front Overlay Keypad.....	4-4
4.9.1. Keypad Buttons and Operation.....	4-4
4.9.2. LED Operation.....	4-5
4.10. Shutting Down the Computer.....	4-5
<b>5. BIOS Settings.....</b>	<b>5-1</b>
<b>6. Diagnostics and Troubleshooting.....</b>	<b>6-1</b>
6.1. Self-Test Diagnostics.....	6-1
6.1.1. System Test and Initialization.....	6-1
6.1.2. System Configuration Verification.....	6-1

6.2.	Troubleshooting .....	6-2
6.2.1.	Power Up.....	6-2
6.2.2.	Display .....	6-3
6.2.3.	Memory .....	6-3
6.2.4.	External PS/2 Mouse.....	6-3
6.2.5.	Keyboard .....	6-4
6.2.6.	Communications .....	6-4
6.2.6.1.	COM Port Connection .....	6-4
6.2.6.2.	Network Communications .....	6-4
6.2.6.3.	Printing.....	6-5
6.3.	Corrective Actions .....	6-5
6.3.1.	CMOS Checksum Error.....	6-5
<b>7.</b>	<b>Technical Data.....</b>	<b>7-1</b>
7.1.	Mechanical Specifications.....	7-1
7.1.1.	Main Enclosure.....	7-1
7.1.2.	Remote Enclosure.....	7-1
7.1.3.	Gland Plate.....	7-1
7.2.	Functional Specifications.....	7-1
<b>8.</b>	<b>Agency Approvals &amp; Government Regulations .....</b>	<b>8-1</b>
8.1.	Agency Approvals .....	8-1
8.2.	Government Regulations.....	8-1
8.3.	Hazardous (Classified) Location / Area.....	8-2
<b>9.</b>	<b>RMA Request &amp; Return Form.....</b>	<b>9-1</b>

# 1. Computer Features

The WOLVERINE II AC with Remote IS System is a high performance workstation comprised of two enclosures. The main enclosure is designed primarily for use in Hazardous and Harsh Environments running on Windows XP® operating systems. The remote enclosure is designed for Non-Hazardous Environments and should be mounted only in a safe area.

The main enclosure is a fully self-contained PC-compatible computer with a built-in flat screen display and resistive touch screen. The unit is housed in a rugged metal case to protect the system against dust, water, and damage in a Harsh Environment. The remote enclosure is a plastic case designed to protect the host Ethernet Intrinsic Safety Barrier in a Controlled Environment.

Both the main enclosure and Remote enclosure are 115/230VAC units that accept a range of 100-240 VAC.

The main enclosure includes heaters for extended temperature operation.

The unit is supplied completely assembled and requires only mounting and connecting.

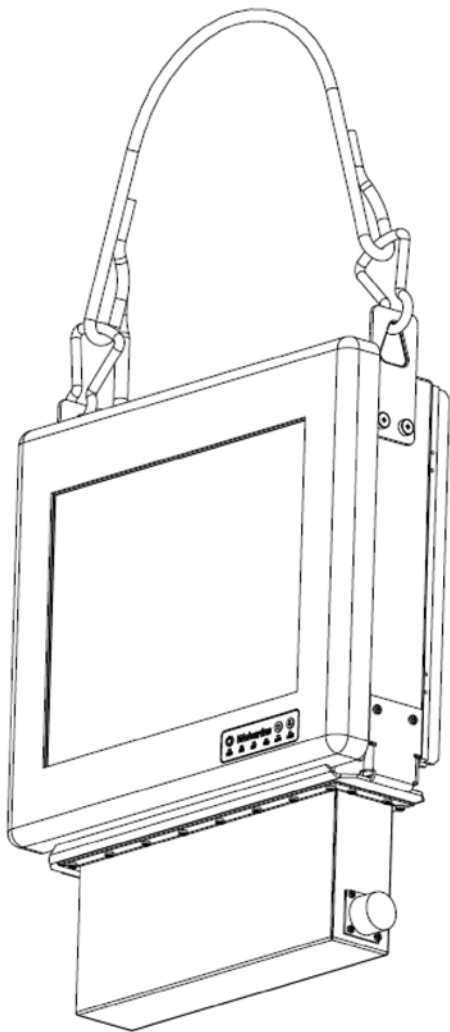

**Figure 1.1:** Main Enclosure

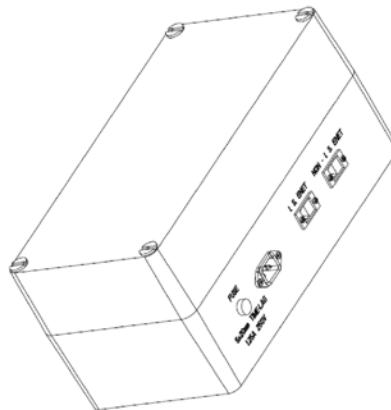

**Figure 1.2:** Remote Enclosure

## 1.1. Feature Summary

When you purchase a WOLVERINE II AC with Remote IS System, you receive:

- Main Enclosure containing 15" Industrial computer with the operating system software installed.
- Remote Enclosure containing Ethernet Intrinsic Safety Barrier
- 25' (7.62m) AC Power cable for Main Enclosure
- Installation hardware
- Microsoft® Windows documentation, software distribution, Certificate of Authenticity and license agreement

### 1.1.1. Standard Features

Feature	Description
Operating System:	Windows XP
CPU	Intel® Pentium M® processor 1.6 GHz
Cache	1 MB L2
Hard disk	40 GB (minimum)
RAM	512 MB, DDR-266 installed by factory.
Display	15.0" Color Active Matrix TFT – XGA 1024x768 resolution, Transflective Daylight readable TFT
Touch Screen	Resistive
Parallel port	LPT1 located on I/O plate
Serial ports	COM1, COM3, COM4 (RS-232), COM2 (RS-232/485) located on I/O plate
USB ports	Two USB 2.0 located on I/O plate
Communications	10/100 Ethernet (RJ-45) with Intrinsic Safety Barriers
Keyboard port	PS/2 located on I/O plate
Mouse port	PS/2 located on I/O plate
PC/104 connector	Populated by PCMCIA PC/104 adapter or A/D card
Panel dimming	Front Keypad Dimming buttons
ATX Switch	Momentary push button
VGA Port	VGA Port located on I/O plate
Gland Plate	IP67 seal for I/O Plate; Cable Glands; External Keyboard, Mouse and USB connections
Wireless Ethernet	802.11 b/g
Heaters	Extended Temperature Operation

### 1.1.2. Back I/O Plates

The back I/O plate provides access to four serial ports, one printer port, one PS/2 keyboard, one PS/2 mouse, two USB 2.0 ports, input power terminal block, fuse, and VGA port. Figure 1.3 indicates the Back I/O plate layout.

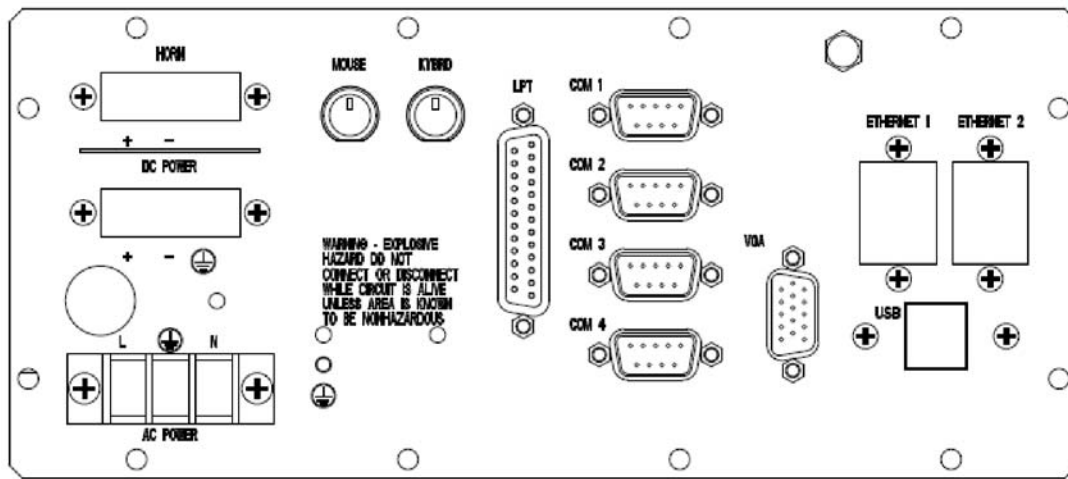

Figure 1.3: Back I/O Plate

### 1.1.3. Gland Plate

All cabling will access the back I/O plate through the gland plate.



Modification of Gland Plate invalidates enclosure protection.

When reinstalling the gland plate, the screws must be tightened to 12 in-lbs (136 Ncm) to ensure the unit is sealed correctly to meet the IP67 enclosure rating.

Input and output wiring methods and cable types must be in accordance with Group II Category 3, Zone 2 wiring methods and in accordance with the authority having jurisdiction.

Keyboard and mouse connectors, two glands, and one USB connector are available on the gland plate shown in Figure 1.4.

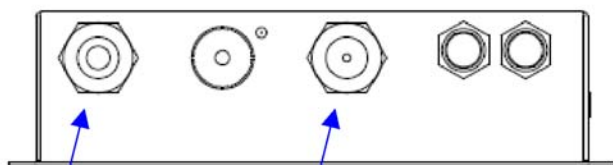
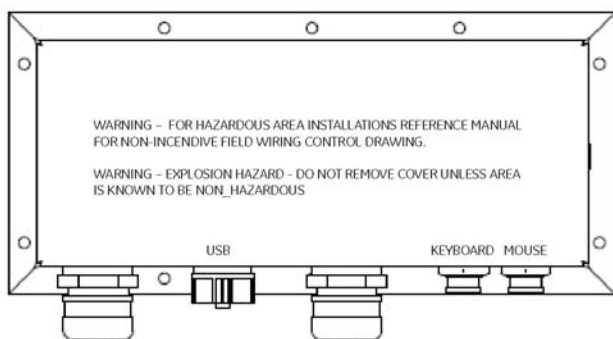

1/4 - 3/8 DIA  
[6.35] - 9.53 DIA  
CABLE GLAND

1/4 - 3/8 DIA  
[6.35] - 9.53 DIA  
CABLE GLAND

**Figure 1.4:** Gland Plate Layout

#### **1.1.4. Power Input**

The input power consists of a three terminal power block. The terminal denoted by the character “L” is for line voltage, the “N” terminal is for the neutral AC return, and  denotes case ground.

The “ATX” switch on the front keypad overlay powers on the unit when depressed. This switch tells the motherboard to turn on the main power supply. Depressing the switch for 4 seconds shuts down the unit. Best practice is for the operating system to power down the unit.

#### **1.1.5. Standard I/O**

The main enclosure provides the following I/O interface channels:

- Four RS-232 serial ports. The user may request for the optional RS-422/485 port in place of RS-232 for COM2. COM ports are accessible from the back I/O plate.
- One enhanced parallel port. LPT1 is located on the back I/O plate.
- Two USB 2.0 Ports are accessible through the back I/O plate. One of these ports is routed to an external USB connector on the Gland Plate.
- VGA port is accessible through the back I/O plate.
- One auto-sensing 10/100 Ethernet adapter available through a circular military connector. An Intrinsic Safety barrier protects the Ethernet circuit and must be connected to the remote enclosure I.S. ENET input to complete the Intrinsically Safe circuit.
- 802.11 b/g wireless Ethernet capable of data transfers up to 54 mbps.

#### **1.1.6. Heaters**

The main enclosure is equipped with AC heaters for extended temperature operation. The components in the remote enclosure are industrial rated and do not require heaters for extended temperature operation.

#### **1.1.7. Front Overlay Keypad**

The front overlay keypad provides an ATX power button and dimming buttons for changing the backlight intensity. LEDs embedded in the overlay provide indicators for system status and various I/O activities. These will be discussed in further detail in Chapter 4 – System Operation.

## 2. Hardware Installation

This chapter describes the procedures for the safe location and securing of the WOLVERINE II AC with Remote IS System. The system has been designed to ensure simple installation.

### 2.1. Installation Guidelines – Main Enclosure

This Main enclosure is designed to operate in an outdoor environment.

- The Main enclosure is furnished with four ¼ -20 mounting holes two on each side and eight ¼-20 VESA mounting holes on the back of the Heat Sink. A cable attached to the enclosure via two carabineers is provided for mounting the unit on a hook.
- The mounting method must be able to support the weight of the unit under shock and vibration conditions for the given application.
- To insure proper operation take care not to install unit in tight confined areas, during mid day operations when the effects of solar heating are at peak radiance, surrounding walls and surfaces can reflect additional solar energy and cause the unit to over heat and shut down until temperatures fall back to normal operating conditions.
- The unit must have a minimum clearance of six inches (154mm) per side and back.
- The unit is available with pass through glands for cable connections (required to maintain enclosure protection rating). These glands are watertight and must be tightened to two complete turns after hand tightening to keep water out. The customer must pass the cables through the glands and wire the associated I/O connectors to the end of these cables.
- When reinstalling the gland plate, the screws must be tightened to 12 in-lbs (136 Ncm) to insure the unit is sealed correctly to meet the IP67 enclosure rating.

### 2.2. Installation Guidelines – Remote Enclosure

- The Remote enclosure is designed to operate in an indoor environment.
- The Remote enclosure is furnished with four M5x0.8mm mounting holes on the bottom of the enclosure.
- The Remote enclosure is not approved for hazardous locations. The Remote enclosure must be installed in a non-hazardous area.

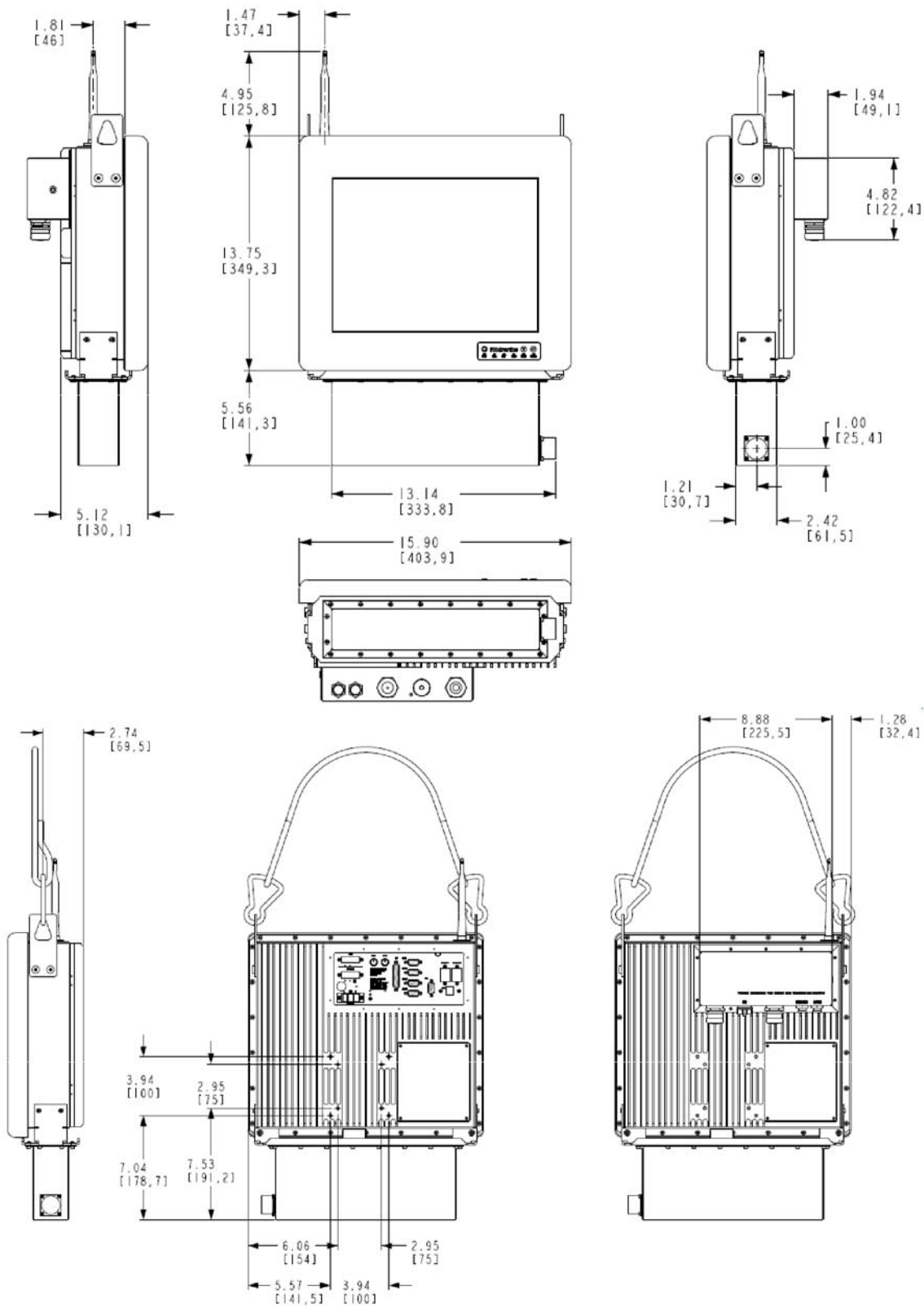

**Figure 2.1:** Illustrations And Dimensions of the Main Enclosure

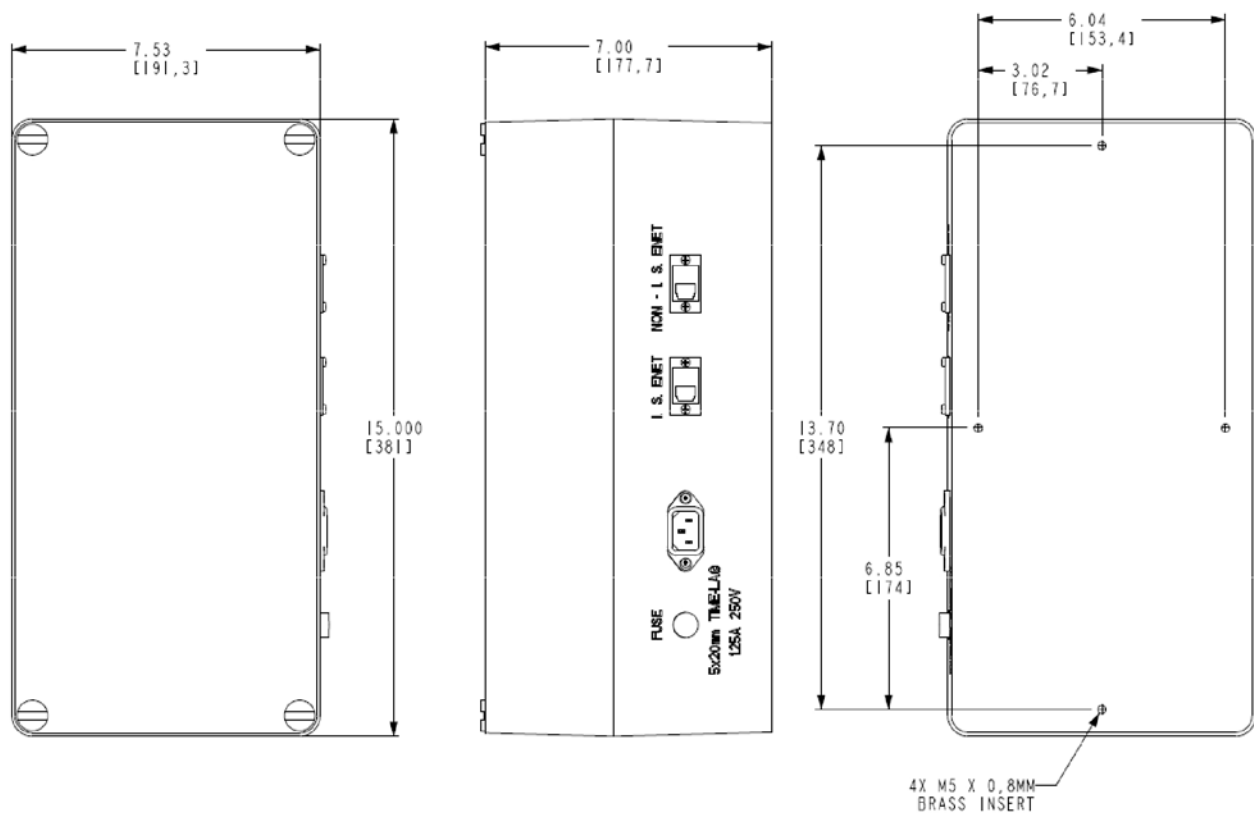

Figure 2.2: Illustrations And Dimensions of the Remote Enclosure

### 2.3. Warnings for Hazardous Area Approvals

- Input and output wiring methods and cable types must be in accordance with Group II Category 3, Zone 2 wiring methods and in accordance with the authority having jurisdiction.
- The Main enclosure is suitable for use in Group II Category 3, Zone 2, Gas group II or non-hazardous locations only.

#### Explosion Hazard



- Substitution of components may impair suitability for Group II Category 3, Zone 2.
- Do not connect or disconnect equipment unless power has been switched off or the area is known to be non-hazardous.
- Do not install or remove SCSI devices or cards while circuit is alive.
- Gland Plate shall be installed for hazardous area applications.
- Product shall be connected to no greater than a 50 Amp branch circuit.
- The proper method for removing power from the unit is to switch off power at the circuit breaker.
- See the control drawing located in Chapter 8 for field wiring parameters.
- Power Pigtail Warning - hot work permit required - do not connect/disconnect power cable in hazardous area
- Antenna Warning - explosion hazard - do not remove or install antenna unless area is known to be non-hazardous
- Enclosure Cover Warning - explosion hazard - do not remove cover unless area is known to be non-hazardous. Warning is applicable to any removable cover on the unit - HDD access door, Gland Plate etc.)
- I/O Cover Warning - for hazardous area installations reference manual for field wiring control drawing

## 2.4. Markings for Hazardous Area Approvals

IP67



II 3 G

Ex [ia] nC II T4

-40° C ≤ Ta ≤ 50° C

## 3. Connectors & Cabling

This chapter describes the connector layout and cabling on the WOLVERINE II AC with Remote IS System All power and communication connectors are described in this section.

Communication connectors are provided from the main CPU motherboard. Most connectors are located on the back I/O plate. All cabling to the I/O plate will be accessed through the glands.

- PS/2 Keyboard (back I/O plate), external Mini-Con-X Keyboard connector (gland plate)
- PS/2 Mouse port (back I/O plate), external Mini-Con-X mouse connector (gland plate)
- Four serial ports, COM1, COM2, COM3, COM4 (back I/O plate).
- Parallel port (back I/O plate)
- Two USB 2.0 ports (back I/O plate), one USB connector (gland plate)
- VGA port (back I/O plate)
- Ethernet 10/100 base T port – Intrinsically Safe (RJ-45 with Circular Military shell – Main enclosure barrier housing)
- Ethernet 10/100 base T port – Intrinsically Safe (RJ-45 - Remote enclosure I.S. ENET)
- Ethernet 10/100 base T port – Non-Intrinsically Safe (RJ-45 - Remote enclosure NON-I.S. ENET)

### 3.1. Power Input – Main Enclosure

The Main enclosure is powered by 115/230VAC, and will operate from 100-240VAC. The unit is powered on through the ATX button located on the front keypad overlay.

A 3' (0.91m) AC power “pigtail” cable with locking connector is provided with the unit and comes pre-wired to the terminal block on the back I/O plate. A 25' (7.62 m) AC power cable is also supplied with the unit and provides a locking connector on one end to mate with the 3' “pigtail” and bare leads on the other end. Connect the green wire to earth ground, black wire to 115/230V AC line, and white wire to AC Neutral. The AC power input shall be connected to no greater than a 50 AMP branch circuit. To remove power from the unit, the proper method is to switch off power at the circuit breaker.

The following information is provided for re-connecting AC input to the terminal block in the event that the user need to disconnect the 3' (1.22 m) AC power “pigtail.” Attach the 115/230V AC line (black wire) to the “L” connection, the AC neutral (white wire) to the “N” connection, and earth ground (green wire) to the

 “connection of the AC power terminal block on the back I/O plate. The terminal block is rated for wire size 12-22 (0.32-3.3mm 2) AWG and has a torque rating of 7 in-lb. (79Ncm) max. It is recommended to use at least 18GA (0.82 mm 2) wire for the power input.



Serious injury due to shock is possible if unit is wired incorrectly or connected to voltage exceeding the input voltage range.

For power supply details, refer to specifications in Chapter 7. There is one user-serviceable fuse on the back I/O plate. The unit comes equipped with an 8A 250V 5x20mm fuse. Suggested replacement fuse – Littelfuse 215008.

### 3.2. Power Input – Remote Enclosure

The Remote enclosure is powered by 115/230VAC, and will operate from 100-240VAC. The unit is powered on by applying power to the IEC power inlet connector.

For power supply details, refer to specifications in Chapter 7. There is one user-serviceable fuse on the front of the Remote enclosure. The unit comes equipped with a 1.25A 250V 5x20mm fuse. Suggested replacement fuse – Littelfuse 2181.25P.



The Remote enclosure must be installed in a safe area. Do not connect power to the Remote enclosure in a hazardous area.

### 3.3. Connector Layout



External devices should not be powered up when connecting to communication ports.

#### Back I/O Plate Connectors

Glands on the gland plate allow cabling to access the back I/O plate connectors.

The back I/O plate consists of:

- 2 USB ports
- 4 RS232 ports – Com 1-4
- LPT port
- Input Power Terminal block
- Keyboard connector
- Mouse Connector
- VGA Port

### 3.4. Printer Port LPT1

A 25-pin D-type female printer port connector is located on the back I/O plate and labeled accordingly. In order to provide higher EMC immunity and maintain CE Mark compliance, the LPT cable must be shielded.

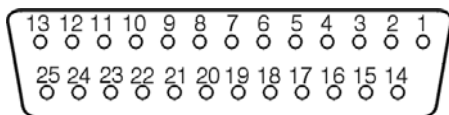
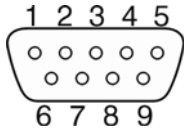

**Figure 3.1:** Printer Port

Pin	Assignment	Pin	Assignment
1	Strobe	10	Acknowledge
2	Data Bit 0	11	Busy
3	Data Bit 1	12	Paper End
4	Data Bit 2	13	Select Out
5	Data Bit 3	14	Auto Feed XT
6	Data Bit 4	15	Error
7	Data Bit 5	16	Initialize Printer
8	Data Bit 6	17	Select In (from Printer)
9	Data Bit 7	18 to 25	Ground

### 3.5. Serial Communication Ports

Four RS-232 COM ports (1-4) are available on the back I/O plate. The standard 9-pin D-sub connector pin out is shown below.



**Figure 3.2:** COM Port

RS-232C Name	Pin	Assignment
CF	1	DCD (Data Carrier Detect)
BB	2	RX (Receive Data)
BA	3	TX (Transmit Data)
CD	4	DTR (Data Terminal Ready)
AB	5	GND (Signal Ground)
CC	6	DSR (Data Set Ready)
CA	7	RTS (Request to Send)
CB	8	CTS (Clear to Send)
CE	9	RI (Ring Indicator)

#### 3.5.1. RS-485 Option

Only COM2 can be selected for RS-485 through SW1 located near the bios chip. To select RS-485 set SW1 to the following:

- (1) On
- (2) On
- (3) Off
- (4) On

Pin	Assignment
1	RS-485 TX-
2	RS-485 TX+
5	GND

#### 3.5.2. RS-422 Option

Only COM2 can be selected for RS-422 through SW1 located near the bios chip. To select RS-422 set SW1 to the following:

- (1) On
- (2) On
- (3) On
- (4) On

Pin	Assignment	Pin	Assignment
1	TX-	6	RTS-
2	TX+	7	RTS+
3	RX+	8	CTS+
4	RX-	9	CTS-
5	GND		

### 3.5.3. Shielding

In order to provide higher EMC immunity and maintain CE Mark compliance, the serial cables must be shielded.

### 3.6. USB Ports

The two USB ports are 2.0 compliant and are located on the back I/O plate. In order to provide higher EMC immunity and maintain CE Mark compliance, the USB cables must be shielded.

### 3.7. VGA Port

The VGA port is available on the back I/O plate. The standard 15-pin D-sub connector pin out is shown below.

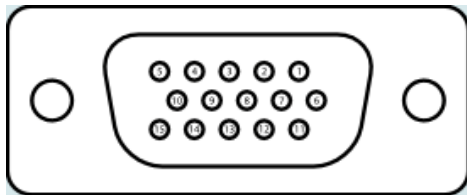

Figure 3.3: VGA Port

Pin	Assignment	Pin	Assignment
1	Red	9	+5V
2	Green	10	Ground
3	Blue	11	Pull-Up
4	N/C	12	DDC Data
5	V Ground	13	HSYNC
6	V Ground	14	VSYNC
7	V Ground	15	DDC Clock
8	V Ground		

### 3.8. Mouse & Keyboard Ports

Connectors are available on the gland plate to allow NEMA4/IP67 connections to a keyboard and mouse without removal of the gland plate. This temporary maintenance connection is intended for such things as initial setup, downloading data, uploading software, etc. The connectors provided on the gland plate are Conxall Mini-Con-X sockets part number 7282-6SG-XXX. See Figure 3.4 for pin-out of these connectors. The mating cable plug is

Conxall part number 6282-6PG-XXX. An adapter cable is also available to convert these connections to standard PS/2 connectors. The adapter cable can be ordered through Computer Dynamics part number CAB011840 (CAB, NEMA4 6-PIN MALE TO PS/2 FEM, 72", TEST) or Conxall part number C1545.

Two PS/2 ports are also available on the back I/O plate and labeled accordingly. This temporary maintenance connection is intended for such things as initial setup, downloading data, uploading software, etc.

Keyboard connector:

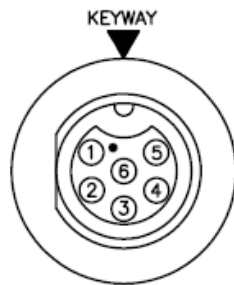

Pin	Signal
1	KB Data
2	NC
3	GND
4	+5V
5	KB Clock
6	NC

Mouse connector:

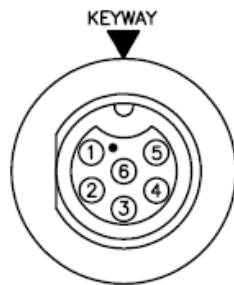

Pin	Signal
1	Mouse Data
2	NC
3	GND
4	+5V
5	Mouse Clock
6	NC

**Figure 3-4:** Mouse & Keyboard Ports

### 3.9. Ethernet Interface

An Intrinsically-Safe Ethernet 10/100BaseT port is provided. The Main enclosure Ethernet connector, located on the barrier housing and labeled "I.S. ENET", is a D38999 Series III Circular Military connector with an integrated RJ-45. This connection provides an IP68 seal when mated. The Remote enclosure provides two standard RJ-45 Ethernet connectors. The port labeled "I.S. ENET" is the Intrinsically safe port and is configured for connection to the Main enclosure Ethernet connector. The port labeled "NON-I.S. ENET" is not Intrinsically safe and is configured for a standard Ethernet connection.

An Ethernet crossover cable (max. length 300 ft) must be used for connecting the Main enclosure to the Remote enclosure. One end of the cable needs to incorporate a D38999 Series III Circular Military connector (P/N RJFTV6MG) for connection to the Main enclosure and a standard RJ-45 on the other end for connection to the Remote enclosure "I.S. ENET" port. Optionally, a 300 ft Ethernet cable with the proper ends installed may be ordered from Computer Dynamics using part number 81A7690-0009.



In order to maintain an Intrinsically Safe Ethernet connection, the Main Enclosure Ethernet must be connected to only the Remote enclosure "I.S. Enet" port. Do not connect to any other Ethernet port.

## 4. System Operation

This chapter provides details of system operation. The following topics are covered:

- Setup
- System Peripherals
- External Keyboard and Mouse
- Graphic System
- Operator Interfaces
- Communications
- Heater Option
- Shutdown

### 4.1. Setup

#### 4.1.1. Powering Up the Wolverine Industrial Computer

The Main enclosure is suitable for use in Group 2 Category 3, Zone 2, Gas group II, or non-hazardous locations only. The Remote enclosure is suitable for use in non-hazardous locations only. Before you attempt to power up the system for the first time, inspect the unit for loose or damaged components.

Before you power up your system, you may want to attach a standard PS/2-type keyboard and mouse to the external ports on the industrial computer. Most configuration activities that you perform on the unit can be more easily completed using a keyboard and mouse.

#### 4.1.2. Powering Down the Wolverine Industrial Computer

In a proper shutdown, the operating system will turn off the power supply and the unit will power down. In the case of an emergency, the ATX switch can be depressed for a quick controlled shutdown of Windows. The ATX switch can also be held down for four seconds for the system to power down without Windows shutting down (this is not a recommended shut down process).



Do not disconnect equipment unless power has been switched off or the area is known to be non-hazardous. To ensure power has been switched off to the unit, the main power should be removed at the circuit breaker, followed by removal of the power cables at Wolverine's power terminal block.

### 4.2. System Peripherals



Do not install or remove Hard Disk Drive while circuit is alive. Failure to observe this precaution could result in damage to the equipment.

#### 4.2.1. Removable Storage Media

The Wolverine industrial computer system has a single removable hard disk drive. The disk drive has a standard EIDE/ATA-2 interface. The standard size is 40GB or larger. Access to the storage media is from the rear access plate.

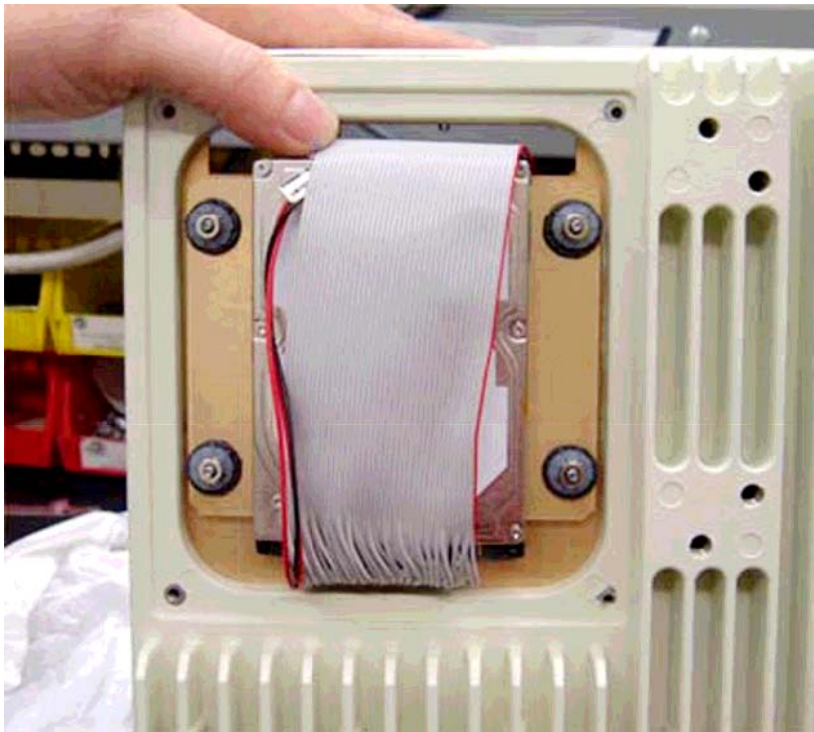
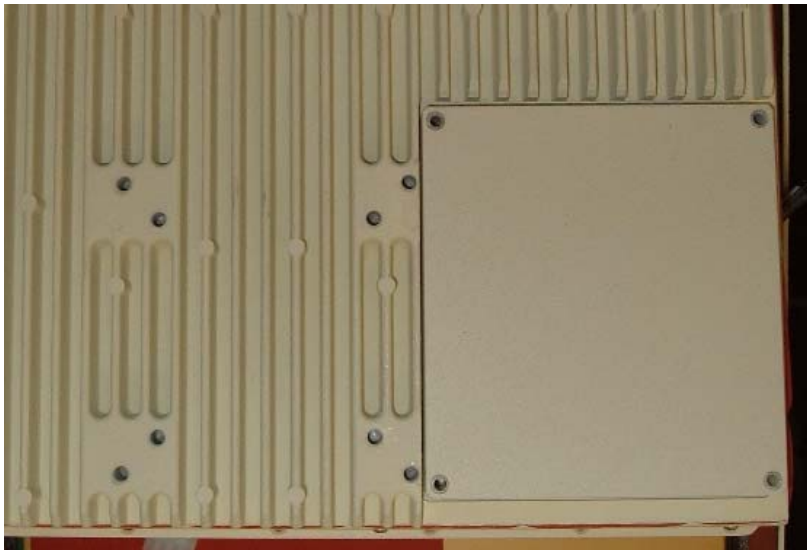

**Figure 4-1:** Storage Media Access



When reinstalling the hard drive access plate, the screws must be tightened to 12 in-lbs (136 Ncm) to insure the unit is sealed correctly to meet the IP67 enclosure rating.

### 4.3. External Keyboard and Mouse

An external PS/2 keyboard and mouse can be attached via two external connectors (Figure 3.4) on the gland plate or to the PS/2 keyboard and mouse connectors (Figure 1.3) on the back I/O plate.

The touch screen and PS/2 mouse will work simultaneously if the mouse is Microsoft or IBM PS/2 compatible.

### 4.4. Graphic System

The Main enclosure includes a 15-inch color TFT (XGA resolution) screen. The flat screen display has the following features:

- High Luminance (equal to or greater than 500cd/m<sup>2</sup>)
- Wide angle viewing
- A built-in back light with a long life back light tube (equal to or greater than 50,000 hrs)
- Transflective technology – allows for sunlight readable viewing

### 4.5. Touch Screen

The Main enclosure includes a Resistive touch screen on the flat panel display.

The touch screen has a resolution of 1024x1024 touch points (independent of screen size) and provides an efficient and reliable method of entering information. The screen responds to the touch of your finger with or without a glove.

The touch screen is connected internally to a USB port.

### 4.6. Touch Screen Driver for Windows

The touch screen driver is installed, configured and calibrated at the time of manufacture.

### 4.7. Communications

Your industrial computer has been configured with networking components that enable you to establish new networks or connect to existing networks easily. If you intend to use Microsoft NetBEUI, TCP/IP, or Direct Cable Connection, some minimal setup changes are required before you can use the system for network applications. In Windows XP systems, these settings are changed using the Network application in the Control Panel program group.

#### Installed Network Components

Network Component	Comments
PCI Network Adapter	Automatically configured in system
TCP/IP	Default settings must be changed before connecting to an existing network. Contact your network administrator for appropriate settings.
NetBEUI	Default settings must be changed before connecting to an existing network. Contact your network administrator for appropriate settings.
System Identification	Computer Name: Each system is uniquely identified by its serial number and can be renamed before adding it to an existing network  Workgroup: The default workgroup is Workgroup. This should be renamed before adding it to an existing network.

## 4.8. Heater Operation

The Main enclosure includes heaters to extend the operating temperature range. Ambient temperatures below or near 0° C will require a warm-up period before power will be applied to the internal ATX power supply. Once power is applied to the ATX power supply the unit will power on automatically\*. The heaters will continue to operate following power-up as needed to maintain internal temperatures above the turn-off threshold.

The HTR LED on the front keypad overlay will illuminate steady when heat is being applied. If the HTR LED flashes then an error has been detected within the heater control system. In this case disconnect external power. Wait 10 seconds and reconnect power. If the problem persists, contact Computer Dynamics at (864-627-8800).



If the BIOS power setting for 'Power on after Power Fail' has been changed then pressing the ATX switch will be required to power the unit on after the warm-up period. Under most conditions the LCD should power on in less than 30 minutes.

## 4.9. Front Overlay Keypad

The Main enclosure includes a front overlay keypad, which provides an ATX power button, dimming buttons, and LEDs to indicate system status and I/O activity.



Figure 4-2: Front Overlay

### 4.9.1. Keypad Buttons and Operation

- ATX power button – press and release to power up or power down the unit. The ATX power button can also be held down for four seconds for the system to power down without Windows shutting down (this is not a recommended shut down process).
- Dimming buttons – used to change backlight intensity. There are seven distinct levels of backlight intensity available. Pressing and releasing a dimming button will change the backlight intensity one level. Holding down a dimming button will quickly scroll through the various backlight intensity levels. The selected brightness level is stored in non-volatile memory. On power up the unit will return to the last brightness level selected.

#### 4.9.2. LED Operation

LED Function	Label	Color	Operation
Power Status	PWR	Green	On when unit is powered on
Heater Status	HTR	Yellow	OFF = Normal operation ON STEADY = Heating Mode FLASHING = Error Detected - unit will not heat or power on
Battery Status	BAT	Green or Red	Green when unit is running on external power Red when unit is running on battery power  Remains unlit on units that do not have battery backup
Hard Drive Status	HDD	Green	On when there is Hard Drive/Compact Flash Activity
Ethernet 1 Status	LINK1	Green or Amber	Green when there is a Link on Ethernet 1 Amber when there is also Activity on Ethernet 1
Ethernet 2 Status	LINK2	Green or Amber	Green when there is a Link on Ethernet 2 Amber when there is also Activity on Ethernet 2

#### 4.10. Shutting Down the Computer



To avoid damaging files, always shut down Windows software before removing power from your Wolverine.

To shut down Windows XP software, select Shut Down from the Start menu.

## 5. BIOS Settings

It is normally not necessary to change the hardware configuration settings in the CMOS memory. If settings become corrupted, follow the procedures here to reload the factory configuration.

1. Power down the computer, connect a keyboard and turn on the power. Enter the Setup mode by pressing the DEL key when prompted during the computer power-up sequence. The main BIOS setup utility screen will appear offering several options for changing settings.
2. Once in the Bios load optimized defaults – this will restore all defaults.
3. Save bios and exit.

## 6. Diagnostics and Troubleshooting

This chapter consists of "Self-Test Diagnostics," "Troubleshooting," and "Corrective Actions." "Self-Test Diagnostics," describes how to respond to errors that could be detected by the automatic self-test that is performed each time the Wolverine industrial computer powers up. "Troubleshooting" contains tables of symptoms, their possible causes, and recommended corrective actions. "Corrective Actions" contains detailed procedures that are too lengthy to include in the Troubleshooting tables.

### 6.1. Self-Test Diagnostics

The computer automatically performs self-test diagnostics each time it is powered up. The self-test consists of a series of checks that verify correct performance of the computer hardware. When the self-test is being performed, you will see the message XXXX M OK displayed on the screen, where XXXX is a number that increases until it matches the amount of usable memory.

#### 6.1.1. System Test and Initialization

These routines test and initialize board hardware. If the routines encounter an error during the tests, you will see an error message on the screen. There are two kinds of errors: fatal and non-fatal. If a non-fatal error occurs, the system can usually continue the boot up sequence. Non-fatal error messages usually appear on the screen with the following instruction:

**Press <F1> to RESUME**

Write down the message and press the F1 key to continue the boot-up sequence.

#### 6.1.2. System Configuration Verification

These routines check the current system configuration against the values stored in the CMOS memory. If they don't match, the program will generate an error message. To correct this condition, you will need to run the BIOS setup program and correct the configuration information in memory.

There are three situations in which you might need to change the CMOS settings:

1. You are starting your system for the first time.
2. You have changed the hardware attached to your system.
3. The CMOS memory had lost power and the configuration information has been erased. If this has happened, call Computer Dynamics (864-627-8800).

## 6.2. Troubleshooting

### 6.2.1. Power Up

Symptom	Possible Causes	Solution
Computer does not power up.	<p>Power not on.</p> <p>Improper shutdown – loss of power</p> <p>Unit in ‘warm-up’ mode HTR LED will be on Steady</p> <p>Error within heater control system HTR LED will be flashing</p>	<p>Make sure that computer is plugged in. Make sure that power source is functioning properly.</p> <p>Depress “ATX” button for 4 seconds. Depress the button again to power on.</p> <p>Wait for unit to finish heating. LCD should power on after warm-up is complete. Press the ATX switch if LCD does not power on automatically after warm-up period. See Chapter 4 – Heater Operation for more details.</p> <p>Disconnect external power. Wait 10 seconds and reconnect power. If the problem persists contact the Computer Dynamics at (864-627-8800).</p>
Display is blank.	See “Display” topic in this Chapter	See “Display” topic in this Chapter
<b>Safe Recovery Error</b> message displayed.	Occurs on initial power up if the unit is accidentally turned off without first shutting down the Windows software.	The computer will power up normally.
<b>CMOS checksum error – Defaults loaded</b>  <b>CMOS battery failed</b> message displayed.	CMOS battery failure.	This battery has a lifetime of up to 10 years under normal operating conditions. For more information, see “CMOS Checksum Error” topic in this chapter.
A screen appears just after powerup, or just after reset, which has the title “CMOS Setup Utility.”	The DEL key has been accidentally pressed.	Cycle power again. The computer will power up normally.
The computer has reset even though the power was not interrupted.	The CTRL-ALT-DEL keys were pressed twice at the same time.	This should never be done, unless you are attempting to reset the computer.

### 6.2.2. Display

Symptom	Possible Causes	Solution
Characters are dim.	Computer screen is in direct light.	Change lighting or adjust contrast.
	Dimming is turned down	Adjust dimming knob to increase brightness
Display is blank.	System temperature is outside operating range.	Keep unit in specified operating temperature range.
	Computer is set up for invalid video mode.	Reboot. Select VGA Mode
	Screen saver is active.	Touch the screen.

### 6.2.3. Memory

Symptom	Possible Causes	Solution
<b>Out of Memory</b> message is displayed or insufficient memory error occurs during operation.	System ran out of memory for the application.	Check the memory requirements for the application. (Refer to the application documentation.)
	Too many terminate and stay resident (TSR) programs running.	Modify the startup folder to use only those TSR applications that are really needed.

### 6.2.4. External PS/2 Mouse

Symptom	Possible Causes	Solution
Cursor does not respond to mouse movement	Mouse not plugged in.	Power down computer. Plug mouse into mouse port on computer and reboot.
	The type of mouse is not supported.	Use a PS/2 mouse.
	System is busy.	Press CTRL-ALT-DELETE to view task list.
	Mouse not detected.	Restart computer with external mouse connected.

## 6.2.5. Keyboard

Symptom	Possible Causes	Solution
External keyboard locks up	The type of keyboard is not supported.	Use PS/2 compatible keyboard
	Keyboard not plugged into keyboard port on the computer.	Plug keyboard in. (Power down computer first.)
	System is busy.	Press CTRL-ALT-DELETE to view task list.

## 6.2.6. Communications

### 6.2.6.1. COM Port Connection

Symptom	Possible Causes	Solution
Communications between the host computer and the controller are unsuccessful.	COM port not configured in system.	Verify that the COM port is configured in the system.
	Cabling between computer and controller.	Verify that the cable between the computer and the controller is correctly wired.
	Baud rate and parity configured incorrectly.	Verify that the baud rate and parity on the computer are consistent with those on the controller.
	Wrong address.	Verify that the slave address is correct.

### 6.2.6.2. Network Communications

Symptom	Possible Causes	Solution
Conflicts on network.	IP Address not unique.	Change the IP address to a unique address. (Contact your system administrator if this or other settings need to be changed.)
	Identical computer name.	Change computer name. Computers cannot share computer name on network.

### 6.2.6.3. Printing

Symptom	Possible Causes	Solution
Printer will not turn on.	Cables not connected properly. Printer power cord not plugged in.	Ensure that the cables are properly connected and that the power cord is connected to the electrical outlet.
Printer will not print.	Printer is not turned on.	Turn on the printer
	Printer is not online.	Set the printer to online.
	The device drivers for your application are not installed.	Install the correct printer drivers for your application in Windows.
	Printer that is set up for a network is not connected to the network.	Connect the printer to the network.
	Printer cable is too long, unshielded, or defective.	Replace the cable.
Printer is offline.	Paper tray is empty.	Fill the paper tray with paper. Set printer to online.
Printer prints garbled information.	Correct printer drivers not installed.	Install the correct printer driver.
	Cable is not connected properly.	Ensure that the printer cable is connected properly to the computer.
	Problem specific to printer.	Run a printer self-test. Refer to the documentation provided with your printer for instructions. If the self-test fails, the problem is printer-specific. The printing section of the software documentation and in Windows online Help may also be helpful.

## 6.3. Corrective Actions

### 6.3.1. CMOS Checksum Error

If the CMOS battery has failed, the following error messages will be displayed on the screen:

CMOS checksum error - Defaults loaded

CMOS battery failed

This battery has a lifetime of up to 10 years under normal operating conditions. If the battery failed, contact Computer Dynamics (864-627-8800).

## 7. Technical Data

### 7.1. Mechanical Specifications

#### 7.1.1. Main Enclosure

The Main enclosure is manufactured from aluminum and houses the motherboard, LCD and touch screen. An access door for the hard drive is located on the back of the Main enclosure. The barrier housing is located at the bottom of the main enclosure.



Modification of Gland Plate invalidates enclosure protection.

When reinstalling the gland plate, the screws must be tightened to 12 in-lbs (136 Ncm) to insure the unit is sealed correctly to meet the IP67 enclosure rating.

Input and output wiring methods and cable types must be in accordance with Group II Category 3, Zone 2 wiring methods and in accordance with the authority having jurisdiction.

#### 7.1.2. Remote Enclosure

The Remote enclosure is manufactured from plastic and houses the remote Ethernet barrier and power supply.

#### 7.1.3. Gland Plate

The gland plate is fixed to the main chassis so that yoke and pedestal mounting configurations have necessary hardware to wire the unit for Hazardous Areas, and also to maintain the enclosure protection rating.

### 7.2. Functional Specifications

CPU and Memory	
Microprocessor	Intel Pentium M processor 1.6 GHz
User Memory	512 MB, DDR-266 minimum installed by factory.
Operating System	Windows XP
Hard Disk	40 Gbyte minimum, IDE standard 2.5-inch mounting

Contact your local distributor for upgrades.

Display	
Display Variants	15-inch Color TFT – XGA
Active Display Area	15-inch – 246 mm x 184.5 mm

Power Requirements – Remote Enclosure	
AC Input	115/230 VAC, 50/60 Hz
Voltage Range	100-240 VAC
Power Rating	4 Watts, 0.1 Amp max

Power Requirements – Main Enclosure	
AC Input	115/230 VAC, 50/60 Hz
Voltage Range	100-240 VAC
Power Rating	780 Watts, 5.8 Amp max

Ports	
Parallel Port	LPT1 (back I/O plate)
Serial Ports	COM1 external RS-232 port (back I/O plate) COM2 external RS-232 port (back I/O plate), Optional RS-485/422 COM3 external RS-232 port (back I/O plate) COM4 external RS-232 port (back I/O plate)
Keyboard Port	PS/2 (back I/O plate) External Mini-Con-X connector (gland plate)
Mouse Port	PS/2 (back I/O plate) External Mini-Con-X connector (gland plate)
USB Ports	USB1 (back I/O plate) USB2 (back I/O plate) External USB (gland plate)
Panel dimming	Front Overlay Keypad
Communication	Intrinsically Safe 10/100 Ethernet (D38999 Series III RJ-45) (barrier housing) 802.11 b/g Wireless Ethernet
VGA Port	VGA port (back I/O plate)



Physical – Remote Enclosure	
Dimensions	381 mm wide (15.00 inches) 178 mm high (7.00 inches) 191 mm deep (7.53 inches)
Weight	2.9 Kg (6.4 lbs)

Physical – Main Enclosure	
Dimensions	404 mm wide (15.90 inches) 491 mm high (19.31 inches) without antenna 616 mm high (24.26 inches) with antenna 179 mm deep (7.06 inches)
Weight	18.8 Kg (41.5 lbs)

Environmental Conditions		
Temperature	Operation	-40° C to +50° C
	Storage	-40° C to +70° C
Humidity	5 to 95% RH (non-condensing)	
Enclosure Protection	MAIN - NEMA4/4X, IP67; REMOTE - IP20	
Altitude (Operating)	Less than 2,000M	

## 8. Agency Approvals & Government Regulations

### 8.1. Agency Approvals

Description	Agency Standard or Marking	Comments
Low Voltage Directive European Safety for Industrial Control Equipment		Self-Declaration in accordance with European LVD Directive 2006/95/EC; Independent 3rd party assessment (Notified Body #0673)
Electromagnetic Compatibility Directive European EMC for Industrial Control Equipment		Self-Declaration in accordance with European EMC Directive 2004/108/EC; Independent 3rd party assessment (Notified Body #0673)
Explosive Atmospheres Directive European Safety for Hazardous Locations Equipment Group II, Category 3, Gas Group II		Self-Declaration in accordance with ATEX Directive 94/9/EC; Independent 3rd party assessment (Notified Body #0673)



A product's approval should be verified by the marking on the unit.

### 8.2. Government Regulations

U.S., Canadian, Australian and European regulations are intended to prevent equipment from interfering with approved transmissions or with the operation of other equipment through the AC power source.

The Wolverine II AC with Remote IS System has been tested and found to meet or exceed the requirements of U.S. (47 CFR 15), Canadian (ICES-003), Australian (AS/NZS 3548), and European (EN55022) regulations for Class A digital devices when installed in accordance with the guidelines noted in the appropriate product section. These various regulations share commonality in content and test levels with that of CISPR 22 and based on this commonality testing to the each individual standard was deemed inappropriate.

The FCC requires the following to be published according to FCC guidelines:



This equipment has been tested and found to comply with the limits for a Class A digital device, pursuant to Part 15 of the FCC Rules. These limits are designed to provide reasonable protection against harmful interference when the equipment is operated in a commercial environment. This equipment generates, uses, and can radiate radio frequency energy and, if not installed and used in accordance with the instruction manual, may cause harmful interference to radio communications. Operation of this equipment in a residential area is likely to cause harmful interference in which case the user will be required to correct the interference at his/her own expense.

Any changes or modifications to the product or installation that are not expressly approved by Computer Dynamics could void the user's authority to operate the equipment under FCC rules.

Industry Canada requires the following note to be published:



This Class A digital apparatus complies with Canadian ICES-003.

### 8.3. Hazardous (Classified) Location / Area

#### Field Wiring Control Drawing, Group II Category 3, Zone 2, Gas Group II

Wolverine II AC with Remote IS  
System Parameters

Acceptable Parameters of an  
Associated Field Wiring Apparatus

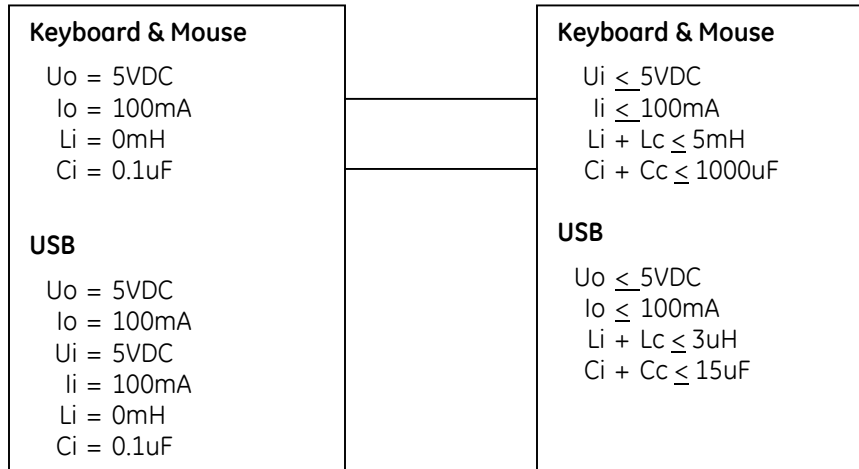

- If the electrical parameters of the cable are unknown, the following values may be used.

$C_c = 60\text{pF}/0.305\text{m}(1\text{ft})$   
 $L_c = 0.20\mu\text{H}/0.305\text{m}(1\text{ft})$

- Terms –
  - $U_o$  = Maximum Output Voltage
  - $I_o$  = Maximum Output Current
  - $U_i$  = Maximum Input Voltage
  - $I_i$  = Maximum Input Current
  - $C_i$  = Internal Capacitance
  - $L_i$  = Internal Inductance
  - $C_c$  = Capacitance of cabling
  - $L_c$  = Inductance of cabling

## 9. RMA Request & Return Form

If you need to return one of our products for repair, please complete our RMA Request Form found on the [support page](#) of our website.

### About Computer Dynamics

Computer Dynamics (A GE Intelligent Platforms Company) is a leading global provider of flat panel display solutions for a wide range of industries and applications. Our comprehensive product offering includes open-frame, enclosed, and environmentally sealed flat panel display systems in both computer and monitor configurations. The company is headquartered in the U.S. and is a part of GE Intelligent Platforms. Whether you're looking for one of our standard products or a fully custom solution, Computer Dynamics has the breadth, experience and 24/7 support to deliver what you need. For more information, visit [www.cdynamics.com](http://www.cdynamics.com).

### Computer Dynamics Contact Information

Americas: 1 864 627 8800

Additional contact information available on our web site at [www.cdynamics.com/contact.asp](http://www.cdynamics.com/contact.asp)

[www.cdynamics.com](http://www.cdynamics.com)

**Computer  
DYNAMICS**

A GE Intelligent Platforms Company

©2010 Computer Dynamics. All Rights Reserved. All other brands or names are property of their respective holders. Specifications are subject to change without notice.

MAN00087 Rev. B