

WDFPKit

**Copyright January 1995
Computer Dynamics, Inc.**

**7640 Pelham Road
Greenville, SC 29615
864-627-8800**

TRADEMARKS

Western Digital® and Paradise® are registered trademarks of Western Digital Corporation.
VESA® is a registered trademark and VBE™ is a trademark of the Video Electronics Standards Association.

COPYRIGHTS

All Western Digital Software, Drivers, and Utilities © 1989-1992 Western Digital Corporation.
All Rights Reserved.
© 1985-1992 Congruent Corporation.
All Rights Reserved.
© 1985-1992 Microsoft Corporation.
All Rights Reserved.

Revised:

Jan 1995
Nov 1995
Apr 1996
Apr 1998
Jun 2000

FCC Testing

This subassembly is marketed to be sold to equipment manufacturers for incorporation into systems. This equipment is not FCC tested. FCC testing is the responsibility of the final equipment manufacturer.

TABLE OF CONTENTS

1. INTRODUCTION	1
1.1 Display Information.....	1
1.2 Features.....	2
1.3 Specifications.....	2
2. WDFPCARD HARDWARE CONFIGURATION	5
2.1 Default Strapping Mode.....	8
2.2 COM A / COM B IRQ (SF1,SF2, SF3).....	9
2.3 COM A / COM B Address (SF4, SF9).....	10
2.4 Video Strapping Options (SF5, SF10).....	10
2.5 Page Select (SF6).....	11
2.6 LPT IRQ (SF7).....	12
2.7 LPT Address (SF8).....	12
2.8 PC Interface (SF12, SF13, SF15, SF16).....	12
2.9 Zero Wait State (SF14).....	13
2.10 COM A RS-232/RS-422 Select (SF17, SF18).....	13
2.11 COM B RS-232/RS-422 Select (SF19, SF20).....	14
2.12 Panel +12V Select (SF21).....	14
2.13 Access LED (LE1).....	15
2.14 VGA Video Interface (J1).....	15
2.15 Printer Interface (J2).....	16
2.16 COM A RS-422 Interface (J3).....	16
2.17 COM B RS-422 Interface (J4).....	17
2.18 COM B RS-232 Interface (J5).....	17
2.19 COM A RS-232 Interface (J6).....	17
2.20 Standard D-Sub Adapter Wiring.....	18
2.21 System Interface (J7, J8).....	19
2.22 PC Interface (P1, P2).....	20
3. WDFPTERM BOARD HARDWARE CONFIGURATION	23
3.1 Default Strapping Mode.....	24
3.2 +12V Source Select (SF1).....	24
3.3 -12V Source Select (SF2).....	25
3.4 SCLK Select (SF3).....	25
3.5 +5V Source Select (SF4).....	26
3.6 Panel +12V Select (SF5).....	26
3.7 Optional VEE Module (VEE1).....	26
3.8 System Interface (J1).....	27
3.9 Flat Panel Interface (J2).....	27
3.10 External Power Input (J3).....	28
3.11 Touchscreen Power (J4).....	28
3.12 Backlight Power (J5).....	29
3.13 Spare Power (J6).....	29
3.14 BLDIM Connector (J7).....	29
4. SYSTEM OVERVIEW	31
4.1 WDFPKit Memory Map.....	33
4.2 WDFPKit I/O Map.....	34
4.3 WDFPKit Interrupt Assignments.....	34
4.4 Flash Programming Voltage port.....	35

4.5	Installation	35
4.5.1	WDFPCard Installation.....	35
4.5.2	WDFPTerm Board Installation.....	35
5.	SOFTWARE OPERATION	37
5.1	Flash Programming Voltage Enable/Disable	37
5.2	Dither Support for Color TFT Flat Panel Displays.....	38
5.2.1	The Dither TSR.....	38
5.3	FVBIOS	40
5.3.1	Interrupt 10H Functions - Video Services.....	41
5.3.2	Interrupt 10H Functions - Western Digital Paradise Extensions.....	43
5.3.3	Interrupt 11H Functions - Return System Information.....	50
5.3.4	Interrupt 12H Functions - Return System Memory Size	50
5.3.5	Interrupt 14H Functions - Serial Services.....	51
5.3.6	Interrupt 15H Functions - Miscellaneous Hardware Services.....	52
5.3.7	Interrupt 17H Functions - Parallel Printer Services.....	53
6.	REFERENCE SECTION	56
6.1	Additional Reading	56
6.2	WDFPKit I/O Options.....	56
6.3	WDFPCard Mating Connectors.....	60
6.4	WDFPTerm Board Mating Connectors.....	61
6.5	Mechanical Outlines.....	62
7.	WARRANTY	65

1. INTRODUCTION

The WDFPKit from Computer Dynamics consists of a WDFPCard, a half-length PC Bus Interface card, and a WDFPTerm board, an active Termination Adapter Board. The WDFPCard is remotely connected to the WDFPTerm board, which is mounted to a sheet metal enclosure driving a flat panel display. The WDFPKit will drive a variety of flat panels, touchscreens and CRT's from virtually any 16-bit ISA computer system. The WDFPKit features a high performance VGA display, which is designed for the rigors of the industrial environment. The WDFPCard is fully compatible with IBM VGA at the hardware, register and BIOS levels.

Included on the WDFPCard are two fully configurable COM ports. These may be set up as RS-232, RS-422 or any combination thereof, and can be configured as COM1, COM2, COM3 or COM4 at IRQ3, IRQ4, IRQ11, IRQ12 or IRQ15. One of these COM ports can be used as an optional touchscreen interface to the panel. Also on the WDFPCard is one fully configurable LPT port with full readback capability, which may be set up as LPT1 or LPT2 at IRQ5 or IRQ7.

The flat panel display and optional touchscreen are housed in a sturdy metal OEM frame and are ready to mount in your enclosure or embed into your product. Applications range from factory and machine control to point of sale terminals, medical equipment and diskless LAN workstations.

1.1 Display Information

The display on any WDFPKit system is an EL (electro luminescent), monochrome LCD (liquid crystal display) or color LCD. Each type has its own operational characteristics and requirements. The LCD makes objects visible at its surface by controlling light (reflected or transmitted) through a glass sandwich. Three main types of LCD's are available today: reflective, transmissive, or transreflective. A reflective LCD uses the ambient light, which is reflected into the panel and does not require any additional light source. Because it uses ambient light, it performs well outdoors or in an office environment. In poor lighting, this type of LCD is not suggested. Transmissive LCD's require a light source behind the panel (backlight). This backlight usually requires a high AC voltage to operate. Because the light source is provided behind the panel, any external ambient light will detract from its visual properties. A transmissive panel is not recommended for outdoor use but is good in office or poor light conditions. The third type of LCD is a combination (or compromise) of the reflective and transmissive types. This type is the transreflective panel. It is a reflective panel which may use a backlight as an additional light source. However, the optical properties of the transreflective unit are not as good as either of the other types. The advantages of LCD panels are mainly in cost and power consumption while the disadvantages are limited viewing angle, low contrast, and slow response time. WDFPKit systems use only the backlight versions of LCD's. The backlight inverter is included with the display.

EL panels are, in their simplest form, an array of LEDs. In the panel structure there is a chemical film which gives off light when subjected to an electrical stimulus. These panels require high dc voltage which is derived from +12Vdc (or +5Vdc) and requires high current. The optical characteristics of EL panels are high contrast with a wide viewing angle and a fast response time. They operate well in most lighting conditions. Because of the fast response time there may be a slight flicker seen which is dependent on the frame rate of the panel.

This manual provides you with instructions to install and operate the Computer Dynamics WDFPKit. The manual also includes a description of all components and a list of supplies and tools you will need to install the kit. After you read this manual, you will be able to:

- Verify jumper settings on the WDFPKit
- Install the WDFPCard in your PC
- Install the WDFPTerm board in your housing
- Connect the display and touchscreen to the WDFPTerm board
- Install the display/touchscreen in your enclosure

In addition to this manual, you should also have available the:

- TBdriver™ manual (*if using touch screen and purchased TBdriver*)
- BLDIM™ manual (*if purchased BLDIM module*)

1.2 Features

- * Standard 6-ft remote capability via a SCSI-2 type connector for driving flat panel display.
- * Optional cable lengths and connectors are available upon request.
- * LCD/EL display controller with Super VGA video.
- * Simultaneous CRT and flat panel display, if desired.
- * Two PC-compatible serial ports selectable as RS-232 or RS-422.
- * RS-422 devices also meet EIA Standard RS-485.
- * Socketed RS-232 DRVR/RCVR parts for quick field replacement.
- * One parallel printer port with read back capability selectable as LPT1 or LPT2.

1.3 Specifications

Compatibility	100% IBM hardware BIOS/software compatible
Video/Display	VGA compatible with analog video output (option). LCD or EL displays installed. Software initialization drivers included.
Serial I/O	Two serial ports configurable as RS-232 or RS-422. Each RS-232 port has a 16-byte FIFO on both transmit & receive. Max baud rate is 115.2Kbaud. Each RS-422 port has the Receiver terminated in 100-ohms between the Differential Pair and meets EIA Standard RS-485 as well.

Parallel I/O

One parallel port. Supports Centronics-type printers or can be used as an I/O port with 8 outputs, 4 inputs, and 5 inputs/outputs.

Environmental

Temperature constraints vary with the display and touchscreen.

PL1/2 0 to 55°C operating temp
-40 to 75°C storage temp

SH3 0 to 45°C operating temp
-25 to 60°C storage temp

SH4/8 0 to 40°C operating temp
-25 to 60°C storage temp

DLx 0 to 55°C operating temp
-55 to 85°C storage temp

GT1/2 0 to 70°C operating temp
-60 to 85°C storage temp

GT3/4 0 to 55°C operating temp
-40 to 85°C storage temp

WDFPKit Option Power Requirements												
WDFPKIT	+5V	+12V	-12V		-panel	+5V	+12V		-TOUCH	+5V	+12V	-12V
WDFPCard	0.50	0.02	0.02		-PL1	NU	2.0		-DLx	NU	0.40	NU
					-PL2	NU	1.8		-GT3	0.20	NU	NU
					-SH3	0.03	0.35		-GT3	0.20	NU	NU
					-SH4	0.09	1.6		-GT1	0.25	0.06	0.06
					-SH8	.007	0.53		-GT2	0.25	0.06	0.06

Touch screen type DLx is any of DL1, DL2, DL3, DL4, DL7 and DL8.

To determine the power requirements for any specific WDFPKit model, add the individual power requirements for each option. For example, a WDFPKit-SH3-DL4 would require:

	+5V	+12V	-12V
WDFPCard	0.50	0.02	0.02
-SH3	0.03	0.35	NU
-DL4	0.40	NU	NU
Total Current	0.93	0.37	0.22

Note:

NU designates not used. All measurements are in amps.

(This page intentionally left blank)

2. WDFPCARD HARDWARE CONFIGURATION

The following drawings and sections show the location of the strapping fields, designated SF, the RS-232 and RS-422 COM ports, the printer port, video connector, and system interface connectors. Before using your WDFPKit, the WDFPCard will need to be strapped, or confirmed, for the environment in which you want it to operate.

Note:

This manual references both Revision B and Revision C WDFPCard. Please verify which Revision you received, as some features are not supported on both boards. The Revision C WDFPCard is shorter in length. Its card-edge is on the AT connector, directly below SF12 and SF13.

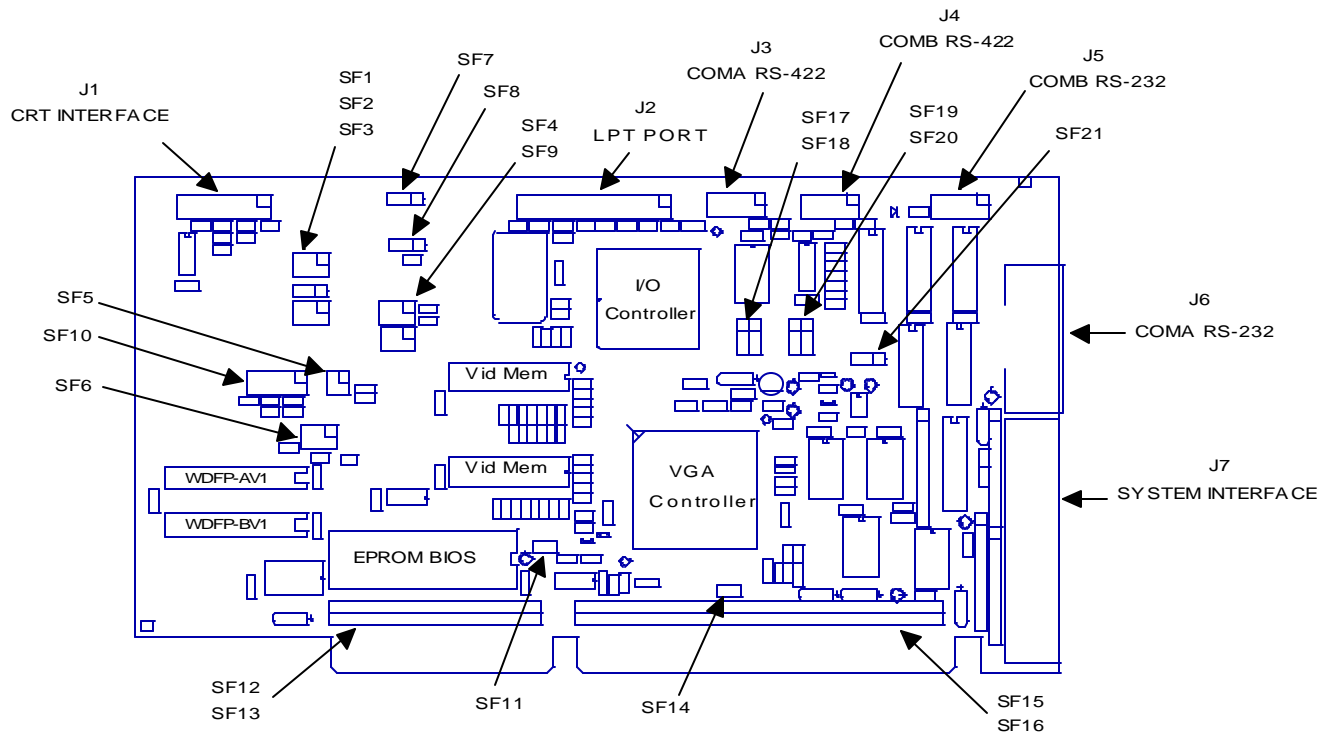

WDFPCard Layout - Revision B

Strapping Field Summary

SF1, SF2, SF3:	COM A/B interrupt
SF4, SF9:	COM A/B address
SF5:	Panel select
SF6:	Page select
SF7:	LPT interrupt
SF8:	LPT address
SF10:	Video strapping
SF11:	Program FLASH device
SF12, SF13:	PC/XT bus
SF14:	Zero wait-states
SF15, SF16:	PC/AT bus
SF17, SF18:	COM A RS-232/RS-422 select
SF19, SF20:	COM B RS-232/RS-422 select

Connector I/O Summary:

J1:	CRT interface
J2:	LPT port
J3:	COM A RS-422 port
J4:	COM B RS-422 port
J5:	COM B RS-232 port
J6:	COM A RS-232 port
J7:	System interface port

SF21:

Panel +12Vdc source

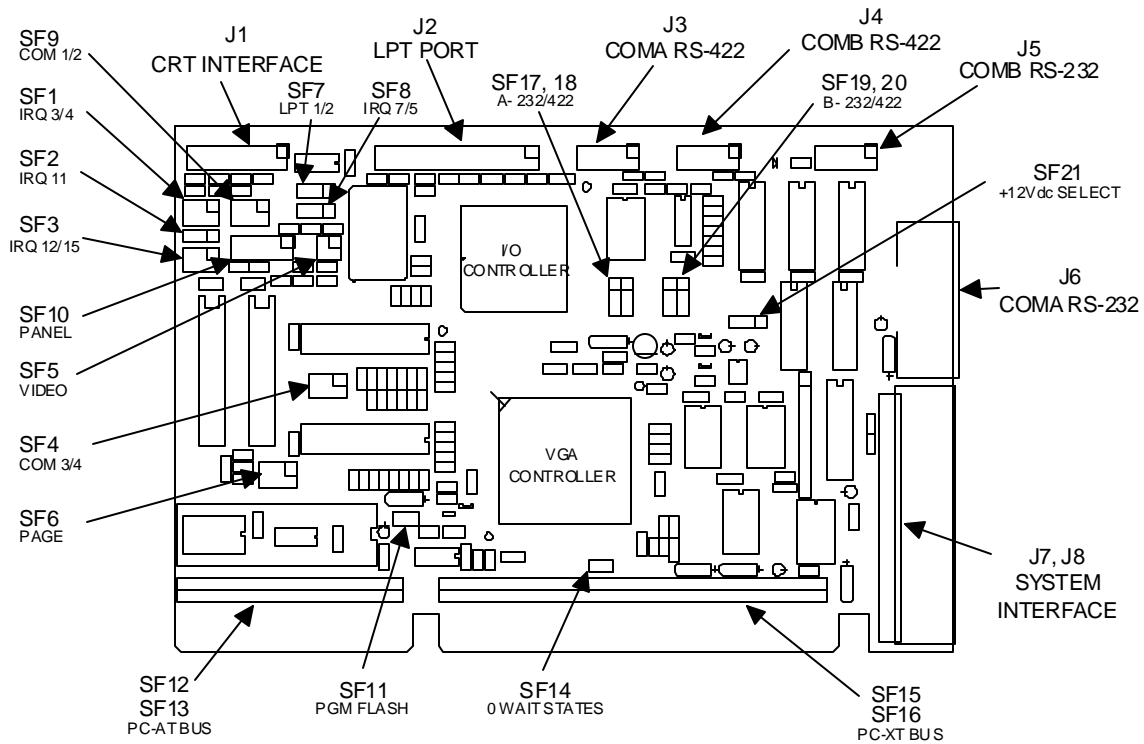

WDFPCard Layout - Revision C

Strapping Field Summary:

SF1, SF2, SF3:	COM A/B interrupt
SF4, SF9:	COM A/B address
SF5:	Panel select
SF6:	Page select
SF7:	LPT interrupt
SF8:	LPT address
SF10:	Video strapping
SF11:	Program FLASH device
SF12, SF13:	PC/XT bus
SF14:	Zero wait-states
SF15, SF16:	PC/AT bus
SF17, SF18:	COM A RS-232/RS-422 select
SF19, SF20:	COM B RS-232/RS-422 select
SF21:	Panel +12Vdc source

Connector I/O Summary:

J1:	CRT interface
J2:	LPT port
J3:	COM A RS-422 port
J4:	COM B RS-422 port
J5:	COM B RS-232 port
J6:	COM A RS-232 port
J7:	System interface port
J8:	Alternate System interface

For both Revisions of the WDFPCard, if the connector or IC is horizontal, pin 1 is located in the top right corner.

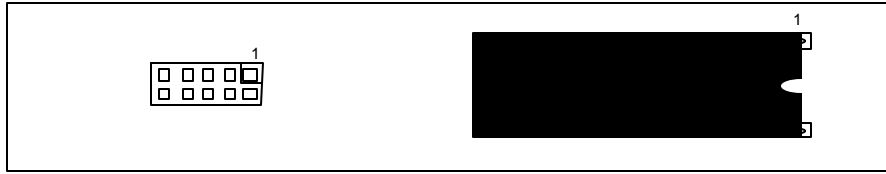

Horizontal Pin 1 Alignment

If the connector or IC is vertical, pin 1 is located in the top left corner.

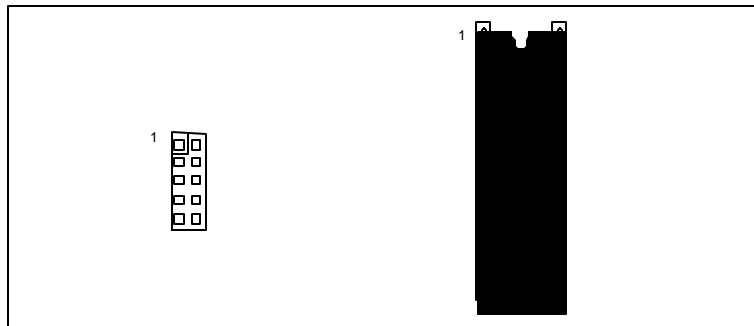

Vertical Pin 1 Alignment

2.1 Default Strapping Mode

When your system is delivered, the WDFPCard will be set-up as noted below. If changes need to be performed for your particular installation, please refer to Sections 2.2 thru 2.12.

NAME	FUNCTION	NOTES	STRAPS
COMA	COM3 (3E8h)	IRQ4 RS-232	SF1: 1-3 SF4: 3-5 SF17: 1-2 SF18: 1-2
COMB	COM4 (2E8h)	IRQ3 RS-232	SF1: 4-6 SF4: 2-4 SF19: 1-2 SF20: 1-2
LPT	LPT2 (278h)	IRQ7	SF7: 1-2 SF8: 1-2
COM IRQ	Alternate Interrupts		SF2: Open SF3: Open
COM ADD	Alternate Addresses		SF9: Open
PGM FLASH	Program the FLASH BIOS		SF11: Open
+12Vdc SELECT	Additional Current to the Panel (Must be set identical to SF5 on WDFPTerm board)		SF21: 1-2
0 WS	Zero Wait-States		SF14: Open
PANEL VIDEO PAGE	TBD at time of purchase		SF5: Preset SF6: at SF10: CDI
XT/AT BUS	PC-Bus Interface		SF12: Open SF13: Open SF15: Open SF16: Open

The standard I/O addresses and interrupts associated with the four PC COM ports are shown in the following table. Note that most BIOS ROM's do not recognize COM3 and COM4 during POST (Power-On System Test) however, most COM port programs do.

PORT	ADDRESS	INTERRUPT
COM1	3F8h	4
COM2	2F8h	3
COM3	3E8h	4
COM4	2E8h	3

PC COM Port Addresses and Interrupts

2.2 COM A / COM B IRQ (SF1, SF2, SF3)

There are two configurable COM ports on the WDFPCard referred to as COM A and COM B. Either COM port interrupt can be selected as IRQ3, IRQ4, IRQ11, IRQ12 or IRQ15 via strapping fields SF1, SF2 and SF3. The COM ports on the WDFPCard cannot share IRQs, thus the straps are physically setup so that each COM port can select a unique IRQ. It is not recommended to select more than one IRQ per COM port, as this will cause irregular problems with system operation. The IRQ selected via these straps must match the IRQ selected by the appropriate software.

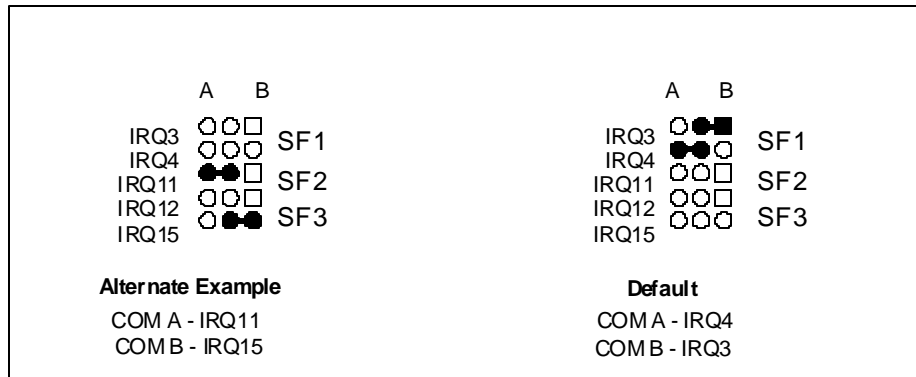

SF1, SF2, SF3: COM Port Interrupt Select

These strapping fields can be used to select any combination of IRQs for the two COM ports, not just the ones exhibited. It should be noted, however, that some software and applications will not recognize non-standard IRQ's for the COM ports such as IRQ11, IRQ12 or IRQ15. These are available for use when conflicts arise in your system.

2.3 COM A / COM B Address (SF4, SF9)

There are two configurable COM ports on the WDFPCard referred to as COMA and COM B. Either COM port address can be selected as COM1, COM2, COM3 or COM4 via strapping fields SF4 and SF9. Each COM port label represents a unique address as noted in the preceding table. The COM ports on the WDFPCard cannot share addresses, and it is not recommended to select more than one address per COM port, as this will cause irregular problems with system operation. The address selected via these straps must match the address selected by the appropriate software.

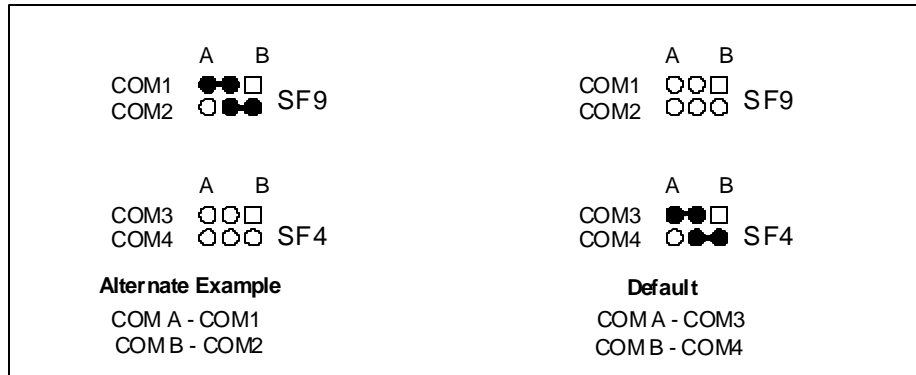

SF4, SF9: COM Port Address Select

These strapping fields can be used to select any combination of addresses for the two COM ports, not just the ones shown. These are available for use when conflicts arise in your system.

Note:

Both COM ports can be disabled by removing all straps from SF1, SF2, SF3 SF4 and SF9. Should you want to disable just one of the COM ports, remove the appropriate straps.

2.4 Video Strapping Options (SF5, SF10)

Strapping fields SF5 and SF10 provide power-on default options for video. These straps will be set to the default value at the factory based on the flat panel configuration ordered.

Note:

The default strapping for the WDFPCard that will drive a monitor is with SF5 and SF10 unstrapped. If the WDFPCard is ordered as part of a Display-Pac, or if it is ordered pre-configured for a specific panel, the default strapping from the factory may be different.

Note:

Due to the constant addition of new flat panel displays supported by the WDFPKit product line, maintaining an up-to-date chart for video strapping in this manual is not possible. The straps in SF5 and SF10 should have been pre-configured for the flat panel in your Display-Pac. If you are experiencing problems with your flat panel, or if you are implementing a different panel, contact your Computer Dynamics Sales Engineer with the flat panel specifics and they will provide you with the appropriate information.

Panel Specific straps (shown here with hatching) will be configured per the customers order at the factory. If additional assistance or changes are needed, call your Computer Dynamics Sales Engineer for Assistance.

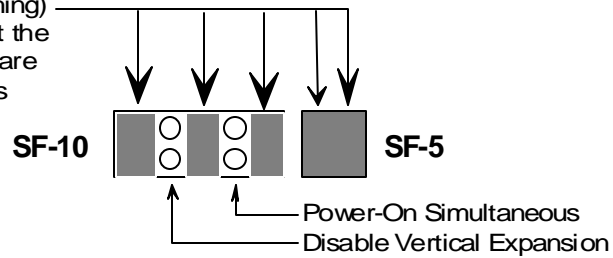

NOTE: The two straps show above shows functionality only. The state of the strap (i.e. whether you insert or remove the strap to achieve the Power-On Simultaneous mode) is panel specific. By default, boards are shipped from the factory configured for NON-Simultaneous operation.

NOTE: The default Vertical Expansion depends mainly on the size of the panel. Normally:
 Panel Height < 480 Lines - Disable Expansion
 Panel Height => 480 Lines - Enable Expansion

SF5, SF10: Video Strapping Options

2.5 Page Select (SF6)

This strapping field selects the correct area from within the ROM for the flat panel being driven. It is preset at the factory, and should only be changed when an alternate panel is to be used with your system. Please call your Computer Dynamics' Sales Engineer should you require an alternate panel selection.

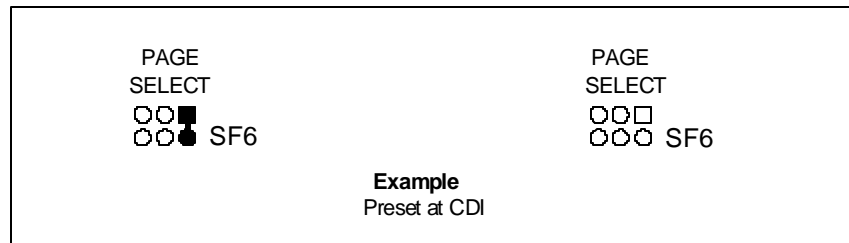

SF6: ROM Page Select

The standard I/O address and interrupt associated with the PC LPT port is shown in the following table. Note that most BIOS ROM's do not recognize LPT2 during POST (Power-On System Test) however, most LPT port programs do.

PORT	ADDRESS	INTERRUPT
LPT1	378h	5
LPT2	278h	7

PC LPT Port Addresses and Interrupts

2.6 LPT IRQ (SF7)

There is one printer port on the WDFPCard and its interrupt can be selected as IRQ5 or IRQ7 via strapping field SF7. The LPT port on the WDFPCard cannot share IRQ's, thus the straps are physically setup so that the LPT port can select a unique IRQ. The IRQ selected via these straps must match the IRQ selected by the appropriate software.



SF7: LPT Interrupt Select

2.7 LPT Address (SF8)

There is one LPT port available on the WDFPCard and its address can be selected as either 378h (LPT1) or 278h (LPT2). Installing a strap as shown in the default position will enable the LPT port at address 278h.

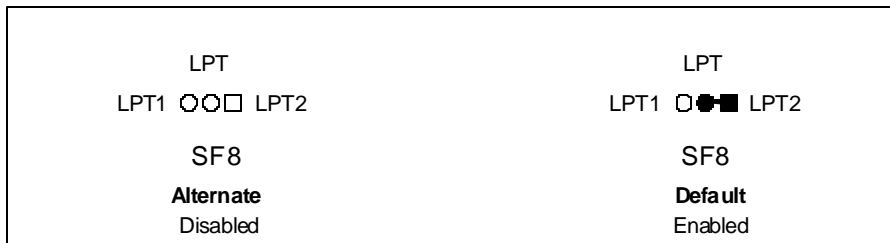

SF8: LPT Address Select

Note:

The Revision B WDFPCard only supports LPT2. The LPT port on either Revision can be disabled by removing straps SF7 and SF8.

2.8 PC Interface (SF12, SF13, SF15, SF16)

Please refer to section 2.22

2.9 Zero Wait State (SF14)

This signal is asserted to indicate that a shorter access time can be executed.



SF14: Zero Wait State Enable

2.10 COM A RS-232/RS-422 Select (SF17, SF18)

Regardless of the address selection of COM A, (COM1-COM4) or the interrupt, (IRQ3, IRQ4, IRQ11, IRQ12, or IRQ15) you may additionally select whether the interface will be RS-232 or RS-422/RS-485. The appropriate drivers and receivers are already installed on board, no additional electronics are required.

Note:

Both sets of straps must be in the same position in order to select the correct interface operation

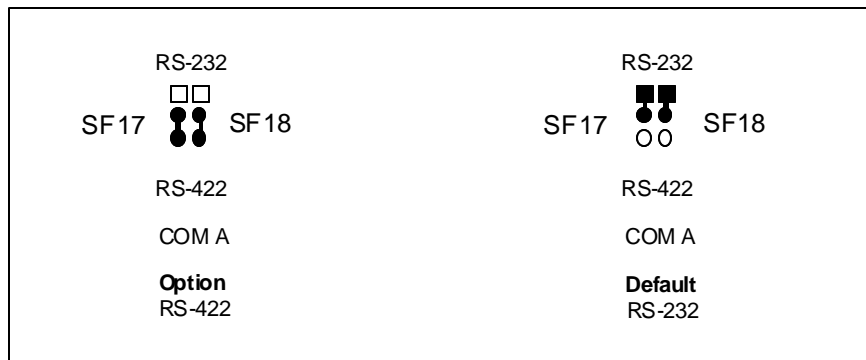

SF17, SF18: COM A RS-232/RS-422 Select

2.11 COM B RS-232/RS-422 Select (SF19, SF20)

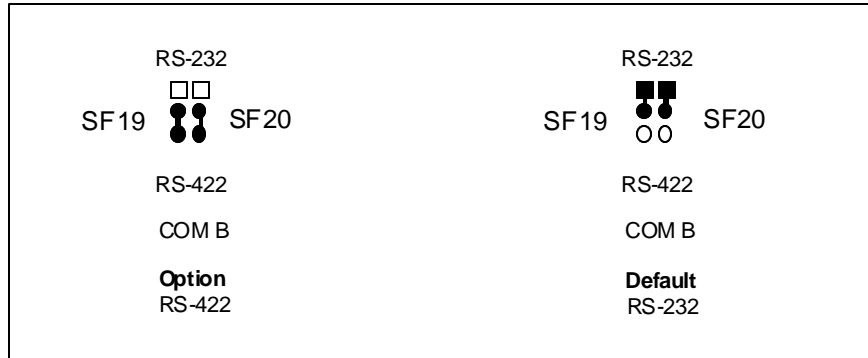

SF19, SF20: COM B RS-232/RS-422 Select

Refer to section 2.10 for operation. This is for COM B using SF19 and SF20.

Note:

It is possible for COM A to be selected as RS-232 simultaneously with COM B selected as RS-422, or vice-versa. COM A port operates independently of COM B port.

2.12 Panel +12V Select (SF21)

This selection allows the user to "double-up" on the +12Vdc being sent to the panel for extra current carrying capabilities. The selection allows constant +12Vdc originating from the power supply to be sent to the panel or "Switched" +12Vdc to be sent to the panel only when accessing it. The latter is often the case when the panel is used in a power-sequencing situation.

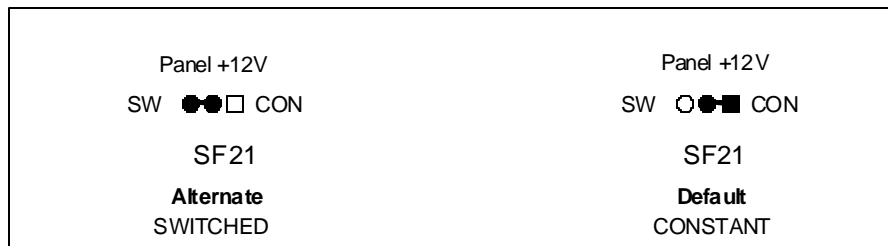

SF21: Panel +12V Select

Note:

This strap must be set identically to SF5 on the WDFPTerm board for proper voltage selection.

2.13 Access LED (LE1)

The Access LED is located between the COMB RS-422 (J4) and COMB RS-232 (J5) interface ports. This LED illuminates when the WDFPCard is being accessed in either a Memory or an I/O location. It serves as a handy troubleshooting aid when determining when the WDFPCard is operating.

2.14 VGA Video Interface (J1)

A VGA monitor can be connected to the WDFPCard using the VGA adapter module available from Computer Dynamics. This module re-routes the signals from the header connector, J1, to the industry standard High-Density 15-pin D-type connector as shown in the following figure.

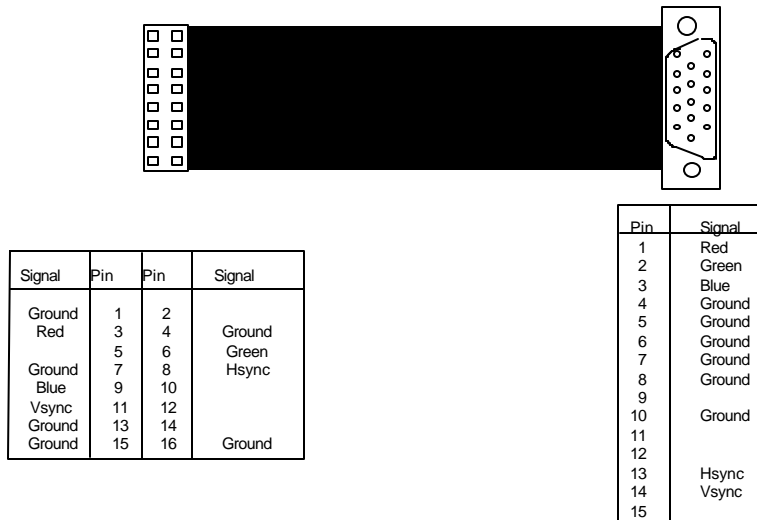

J1: WDFPCard SVGA Cable

2.15 Printer Interface (J2)

The printer port on the WDFPCard is flat-cable-compatible with the standard PC 25-pin parallel connector as shown in the following figure. The 25-pin connector for the printer port is typically a female connector.

The 25-pin connector can be converted to a Centronics-compatible connector using an adapter cable available from most computer stores.

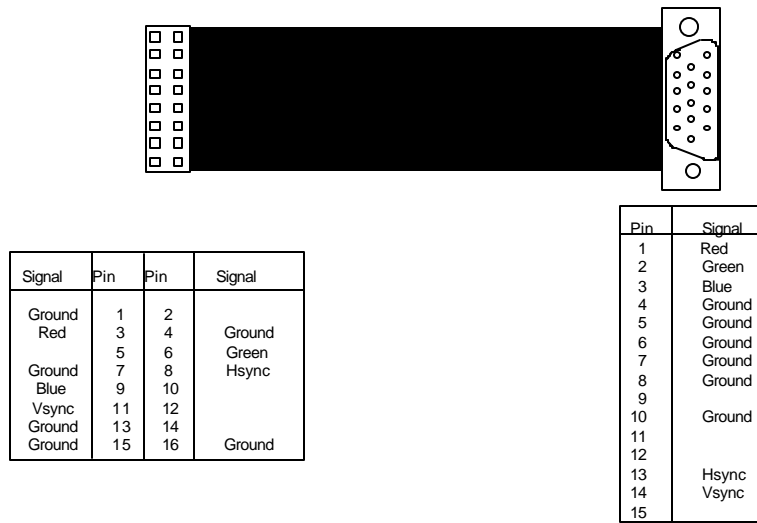

2.16 COM A RS-422 Interface (J3)

The COMA RS-422 serial port has pinouts defined below. The input signals are terminated in 100-ohm impedance between the differential pairs. The output signals are un-terminated. Both the RTS and CTS lines are provided for applications requiring handshake capabilities. The connector on the WDFPCard is a 2 row x 5 pin, .100" center. Computer Dynamics manufactures an accessory kit, which contains a female, DB-25 interface connector.

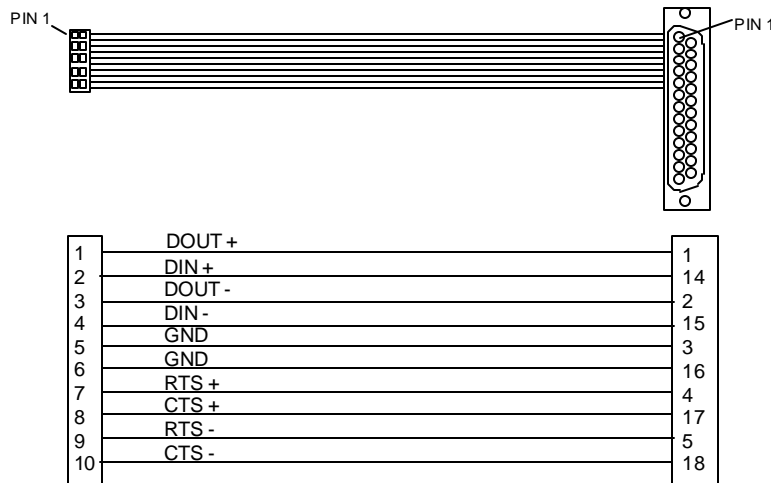

J3, J4: COM A/B RS-422 Pinouts

2.17 COM B RS-422 Interface (J4)

The COM B RS-422 serial port is identical to J3 above.

2.18 COM B RS-232 Interface (J5)

The COM B RS-232 serial port is flat-cable compatible with the standard PC 9-pin serial connector as shown in the following figure. Computer Dynamics manufactures an accessory kit, which contains a male, DB-9 interface connector.

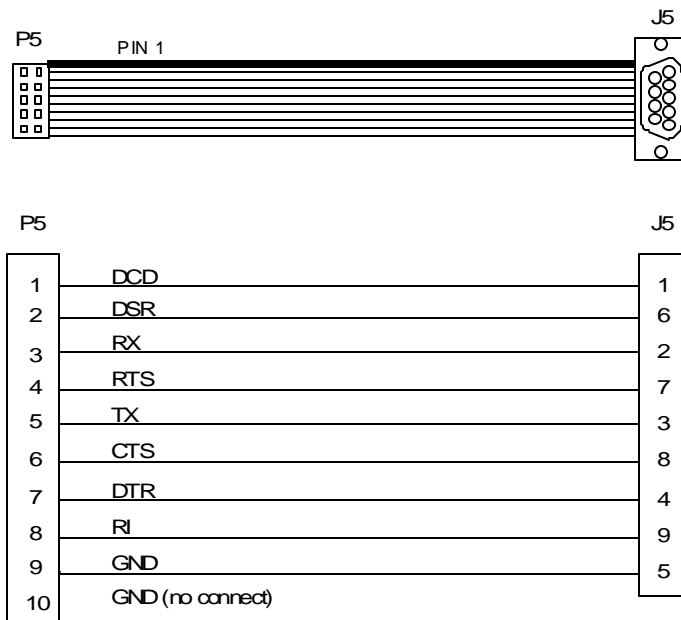

J5: COM B RS-232 Pinout

2.19 COM A RS-232 Interface (J6)

The COM A RS-232 serial port is a PC standard 9-pin D-subminiature male connector. Touch screen interfaces purchased from Computer Dynamics are pin compatible with this connector. The typical mouse is also compatible with this connector. The pin definition of this connector is shown in the following table.

Pin	Function
1	Received Line Signal Detect
2	Received Data

3	Transmitted Data
4	Data Terminal Ready
5	Ground
6	Data Set Ready
7	Request To Send
8	Clear To Send
9	Ring Indicator

J6: COM A RS-232 Pinout

2.20 Standard D-Sub Adapter Wiring

Many devices now support the standard PC 9-pin connector. The original 25-pin connector may be connected as shown. This adapter is available from many suppliers. The 25-pin connector is typically a male. Note that the signal directions are those for data terminal equipment (DTE). The 25-pin connector is flat-cable compatible with modems.

1	RLSD	8
2	RX	3
3	TX	2
4	DTR	20
5	GND	7
6	DSR	6
7	RTS	4
8	CTS	5
9	RI	22

9-Pin to 25-Pin Adapter Wiring

2.21 System Interface (J7, J8)

The system interface cable comes standard as a 6-ft, 50-pin SCSI-2 type cable and connects the WDFPCard to the WDFPTerm board via J7. This cable carries all voltages and signals required to drive flat panel displays (LCD, EL, Plasma, etc.) The following table illustrates the physical and electrical layout of the SCSI-2 type connector. This cable consists of 25 twisted pairs with pins 1 and 26 being a twisted pair, pins 2 and 27 a twisted pair, pins 3 and 28 a twisted pair and so on.

There are 4 pairs of RS-422 signals within this cable, two located on the far left side and two located on the far right side, and are designated as *(signal name) +* and *(signal name) -*. These are the control signals required for the panel interface and are decoded on the WDFPTerm board.

Note:

For Revision C WDFPCard only:

For shorter cable distances, or special system requirements, an alternate System interface connector, J8, is provided for installation in place of the SCSI-2 connector. J8 is a 2mm header, which interfaces to 1mm flat-ribbon cable. It is pinned out identically to J7.

WARNING:

This is **NOT** a port designed to run SCSI-2 type devices and plugging in such a device to this cable may cause damage to the WDFPCard and/or the SCSI-2 device.

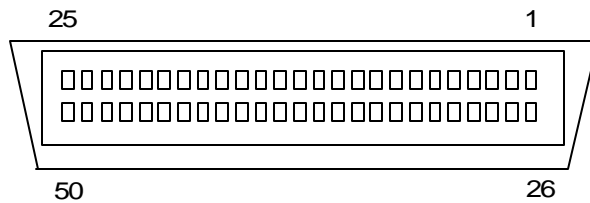

SCSI-2 (FRONT VIEW)

SIGNAL	PIN	PIN	SIGNAL
SCLK -	1	26	SCLK +
DATA EN -	2	27	DATA EN +
GROUND	3	28	VIDEO00
VIDEO01	4	29	GROUND
VIDEO17	5	30	+5Vdc
GROUND	6	31	VIDEO02
VIDEO03	7	32	GROUND
-12Vdc	8	33	+12Vdc SELECT
GROUND	9	34	VIDEO04
VIDEO05	10	35	GROUND
VIDEO15	11	36	CON
GROUND	12	37	VIDEO06
VIDEO07	13	38	GROUND
+5Vdc	14	39	+5Vdc
GROUND	15	40	VIDEO08
VIDEO09	16	41	GROUND
RESET	17	42	VIDEO14
GROUND	18	43	VIDEO10
VIDEO11	19	44	GROUND
VIDEO16	20	45	+5Vdc
GROUND	21	46	VIDEO12
VIDEO13	22	47	GROUND
+12Vdc	23	48	+12Vdc
V SYNC -	24	49	V SYNC +
H SYNC -	25	50	H SYNC +

J7, J8: System Interface Pin Definition

2.22 PC Interface (P1, P2)

The WDFPCard is a PC bus-compatible board and will plug directly into any available 16-bit slot in your computer chassis. P1 is the larger connector and represents the XT bus. P2 is the smaller connector and represents the AT bus.

P1A is electrically identical to SF15.

P1B is electrically identical to SF16.

P2A is electrically identical to SF12.
P2B is electrically identical to SF13.

Electrical positions SF12, SF13, SF15 and SF16 provide convenient test points in which to monitor bus activity.

Signal	XT Bus Pin	P1 Pin	P1 Pin	XT Bus Pin	Signal
/IO Channel Check	A1	1	2	B1	Ground
SDATA 07	A2	3	4	B2	Reset Driver
SDATA 06	A3	5	6	B3	+5Vdc
SDATA 05	A4	7	8	B4	IRQ 2
SDATA 04	A5	9	10	B5	-5Vdc
SDATA 03	A6	11	12	B6	DRQ 2
SDATA 02	A7	13	14	B7	-12Vdc
SDATA 01	A8	15	16	B8	/0WS
SDATA 00	A9	17	18	B9	+12Vdc
IO Channel Ready	A10	19	20	B10	Ground
AEN	A11	21	22	B11	/MEMW
SADDRESS 19	A12	23	24	B12	/MEMR
SADDRESS 18	A13	25	26	B13	/IOW
SADDRESS 17	A14	27	28	B14	/IOR
SADDRESS 16	A15	29	30	B15	/DACK 3
SADDRESS 15	A16	31	32	B16	DRQ 3
SADDRESS 14	A17	33	34	B17	/DACK 1
SADDRESS 13	A18	35	36	B18	DRQ 1
SADDRESS 12	A19	37	38	B19	/DACK 0
SADDRESS 11	A20	39	40	B20	CLOCK
SADDRESS 10	A21	41	42	B21	IRQ 7
SADDRESS 09	A22	43	44	B22	IRQ 6
SADDRESS 08	A23	45	46	B23	IRQ 5
SADDRESS 07	A24	47	48	B24	IRQ 4
SADDRESS 06	A25	49	50	B25	IRQ 3
SADDRESS 05	A26	51	52	B26	/DACK 2
SADDRESS 04	A27	53	54	B27	T/C
SADDRESS 03	A28	55	56	B28	ALE
SADDRESS 02	A29	57	58	B29	+5Vdc
SADDRESS 01	A30	59	60	B30	14.3818 MHz
SADDRESS 00	A31	61	62	B31	Ground
+5Vdc	No Pin	63	64	No Pin	Ground

P1: PC/XT Bus Connections

Signal	AT Bus Pin	P2 Pin	P2 Pin	AT Bus Pin	Signal
/SBHE	C1	1	2	D1	/MEM CS 16
LA 23	C2	3	4	D2	/IO CS 16
LA 22	C3	5	6	D3	IRQ 10
LA 21	C4	7	8	D4	IRQ 11
LA 20	C5	9	10	D5	IRQ 12
LA 19	C6	11	12	D6	IRQ 15
LA 18	C7	13	14	D7	IRQ 14
LA 17	C8	15	16	D8	/DACK 0
/MEMR	C9	17	18	D9	DRQ 0
/MEMW	C10	19	20	D10	/DACK 5
SDATA 08	C11	21	22	D11	DRQ 5
SDATA 09	C12	23	24	D12	/DACK 6
SDATA 10	C13	25	26	D13	DRQ 6
SDATA 11	C14	27	28	D14	/DACK 7
SDATA 12	C15	29	30	D15	DRQ 7
SDATA 13	C16	31	32	D16	+5Vdc
SDATA 14	C17	33	34	D17	/MASTER
SDATA 15	C18	35	36	D18	Ground

P2: PC/AT Bus Connections

3. WDFPTERM BOARD HARDWARE CONFIGURATION

The WDFPTerm board is an active termination board, which has provisions to mount directly to the sheet metal to which the panel is affixed. It is a system requirement and serves as an interface between the WDFPCard and the desired panel. The WDFPTerm board will accept all Computer Dynamics' standard panel interface cards directly into connector J2.

The following drawing shows the location of the all strapping fields, power connectors, panel interface connector, and system interface connector. Before using your WDFPKit, the WDFPTerm board will need to be strapped, or confirmed, for the environment in which you want it to operate. The following sections define the strapping fields, their defaults and configuring them for your operating environment.

Note:

The WDFPTerm Board operates with any Revision of the WDFPCard.

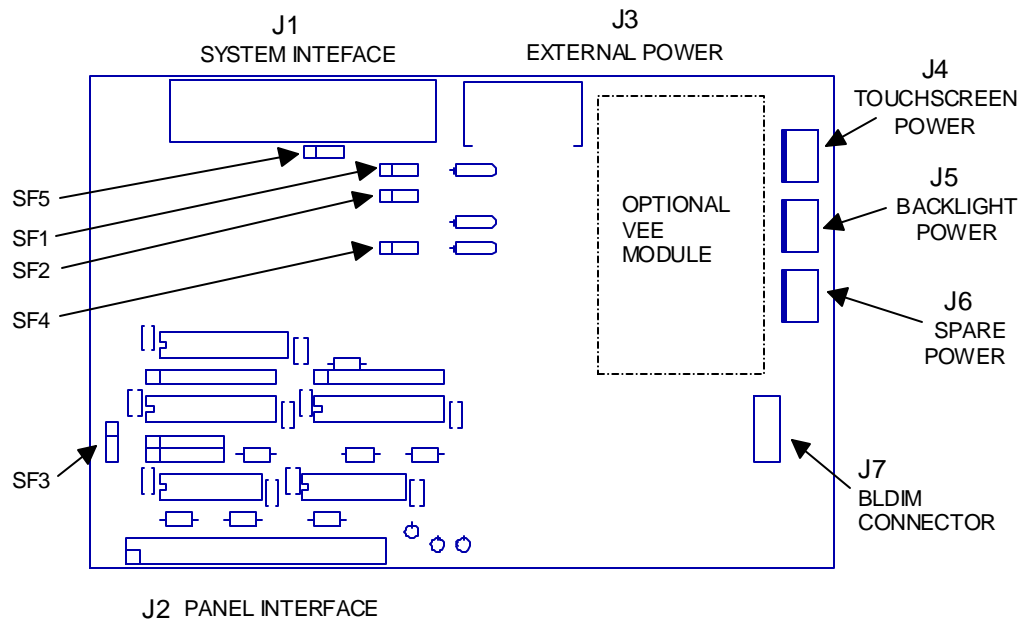

WDFPTerm Board Layout

Strapping Field Summary:

- SF1: +12Vdc Source
- SF2: -12Vdc Source
- SF3: SCLK Polarity
- SF4: +5Vdc Source
- SF5: Panel +12Vdc Select

Connector I/O Summary:

- J1: System Interface
- J2: Panel Interface
- J3: External Power Input
- J4: Touchscreen Power Output
- J5: Backlight Power Output
- J6: Spare Power Output
- J7: BLDIM Connector

3.1 Default Strapping Mode

When the system is delivered, the WDFPTerm board will be set-up as noted below. If changes need to be made for your particular installation please refer to Sections 3.2 thru 3.6.

NAME	FUNCTION	STRAPS
+12Vdc SOURCE	Internal vs. External origin of +12Vdc	SF1: 1-2
-12Vdc SOURCE	Internal vs. External origin of -12Vdc	SF2: 1-2
SCLK	Polarity of the System Clock	SF3: 2-3
+5Vdc SOURCE	Internal vs. External origin of +5Vdc	SF4: 1-2
+12Vdc SELECT	Additional current to the Panel (Must be set identical to SF21 on WDFPCard)	SF5: 1-2

3.2 +12V Source Select (SF1)

This strap provides selection for the source of the +12Vdc to the touchscreen power connector, backlight power connector, spare power connector, BLDIM connector, panel interface connector, and the optional VEE module.

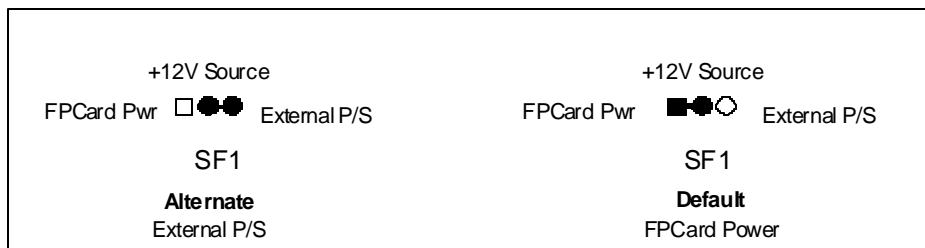

SF1: +12V Source Select

3.3 -12V Source Select (SF2)

This strap provides selection for the source of the -12Vdc to the touchscreen power connector, backlight power connector, spare power connector, BLDIM connector, panel interface connector, and the optional VEE module.



SF2: -12V Source Select

3.4 SCLK Select (SF3)

The polarity of the system clock with respect to the data may vary from panel to panel. This polarity is preset at Computer Dynamics prior to shipment, and the default is as shown. If you change panels, it may be necessary to select the negative polarity of the system clock for proper operation.



SF3: SCLK Polarity Select

Note:

This is a hard-wire jumper on the PC board.

3.5 +5V Source Select (SF4)

This strap provides selection for the source of the +5V to the WDFPTerm board, the touchscreen power connector, backlight power connector, spare power connector, BLDIM connector, panel interface connector, and the optional VEE module.

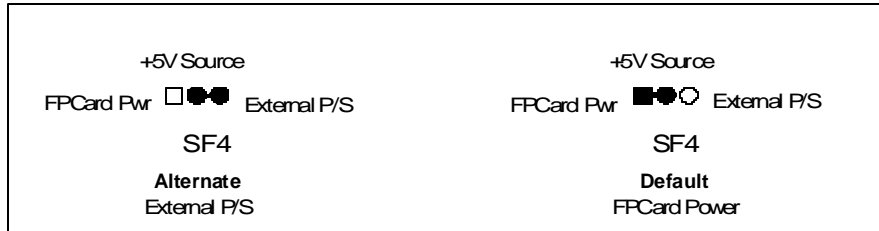

SF4: +5V Source Select

3.6 Panel +12V Select (SF5)

This selection allows the user to double-up on the +12Vdc being sent to the panel for extra current carrying capabilities. The selection allows constant +12Vdc originating from the power supply to be sent to the panel or "Switched" +12Vdc to be sent to the panel only when accessing it. The latter is often the case when the panel is used in a power-sequencing situation.



SF5: Panel +12V Select

Note:

This strap must be set identically to SF21 on the WDFPCard in order for proper voltage selection.

This is a hard-wire jumper on the PC board.

3.7 Optional VEE Module (VEE1)

This is an optional module, which can be plugged directly into the WDFPTerm board when an inverter board is not present. As this will rarely be required in the field, this module can be purchased directly from your Computer Dynamics' Sales Engineer.

3.8 System Interface (J1)

This is identical to the system interface connector J7 on the WDFPCard. Please refer to Section 2.21.

3.9 Flat Panel Interface (J2)

Flat panel displays (liquid crystal displays, electro-luminescent, plasma, etc.) may be connected to the WDFPTerm board through J2, a 2 x 20 flat-cable compatible header connector. This connector can be used with panels with dual-row and some single-row connectors. Computer Dynamics offers cable interfaces for common LCD or EL displays. Contact your Computer Dynamics' Sales Engineer for availability on specific panel interfaces.

Signal	Pin	Pin	Signal
Con	1	2	B3/RGB3/VD15
Blank/WF/FR	3	4	UD3/R3/RGB15/VD7
LP	5	6	LD3/G3/RGB9/VD3
PCLK/XSCLL	7	8	RGB11/VD11
Reset	9	10	RGB11/VD11
Ground	11	12	RGB10/VD10
Ground	13	14	RGB17/VD9
Ground	15	16	RGB16/VD8
Ground	17	18	RGB4 for 18 Bit TFT/VD16
LD1/G1/RGB7/VD1	19	20	RGB5 for 18 Bit TFT/VD17
LD0/G0/RGB6/VD0	21	22	Ground
B2/RGB2/VD14	23	24	Ground
B1/RGB1/VD13	25	26	+5Vdc
+5Vdc	27	28	N/C
VRTC/YD/FP	29	30	N/C
Inverted PCLK/XSCLK	31	32	B0/RGB0/VD12
UD2/R2/RGB14/VD6	33	34	Key
UD1/R1/RGB13/VD5	35	36	+12Vdc
UD0/R0/RGB12/VD4	37	38	Switched +12Vdc
LD2/G2/RGB8/VD2	39	40	-12Vdc

J2: Panel Interface

- Blank/WF is the blanking signal for CRTs, plasma and EL panels. It is the backplane bias signal for LCD's.
- LP is the latch pulse for LCD's.
- PCLK/XSCLL is the pixel clock for CRTs. It is the shift clock for LCD's.
- R0-R3, G0-G3 and B0-B3 are the data bits for 3-bit, 9-bit, and 12-bit TFT's.
- RGB0-RGB17 are the data bits for 18-bit TFT's.
- UD0-UD7 are the data bits for the upper half of dual screen LCD's.
- LD0-LD7 are the data bits for the lower half of dual screen LCD's.
- Switched +12Vdc can be used in power sequencing for flat panels requiring a LCD bias voltage of +12Vdc.

3.10 External Power Input (J3)

This connector is the same as the power connector on 5.25" floppy drives. Shown below is the electrical pinout. Computer Dynamics recommends using an external power supply for system interface cabling distances over 6-ft. When installing an external power supply, ensure strapping fields SF1, SF2 and SF4 are in the correct position.

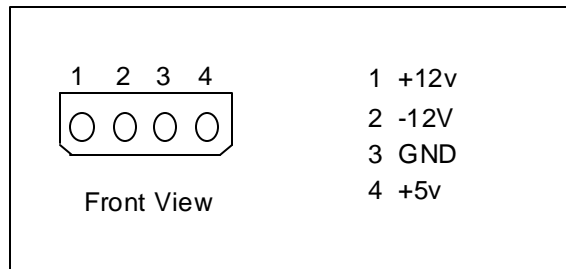

J3: External Power Input

3.11 Touchscreen Power (J4)

This connector is the same as the power connector on 3.5" floppy drives. If using a touchscreen interface, plug the cable into this connector.

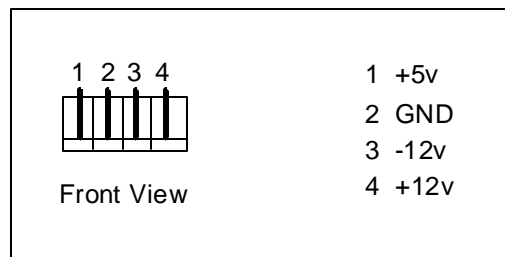

J4, J5, and J6: Accessory Power

3.12 Backlight Power (J5)

This connector is identical both physically and electrically to the touchscreen power connector, J4.

3.13 Spare Power (J6)

This connector is identical both physically and electrically to the Touchscreen Power connector, J4.

3.14 BLDIM Connector (J7)

The BLDIM product is primarily intended to light (or drive) LCD panel backlights. It does this using dc-to-ac inverters. The following diagram shows the pinout of the BLDIM and is a 2x5 connector.

Note:

Refer to the BLDIM manual for details on installation and hook-up.

SIGNAL	PIN	PIN	SIGNAL
+5Vdc	1	2	+12Vdc
Switched +12Vdc	3	4	Ground
VEE +	5	6	VEE -
Ground	7	8	CON
Ground	9	10	Mechanical Key

J7: BLDIM Connector Pinout

(This page intentionally left blank)

4. SYSTEM OVERVIEW

The WDFPKit works as a system to provide a PC/AT with an interface to flat panels and CRT's. The following diagram is a block representation of the WDFPKit.

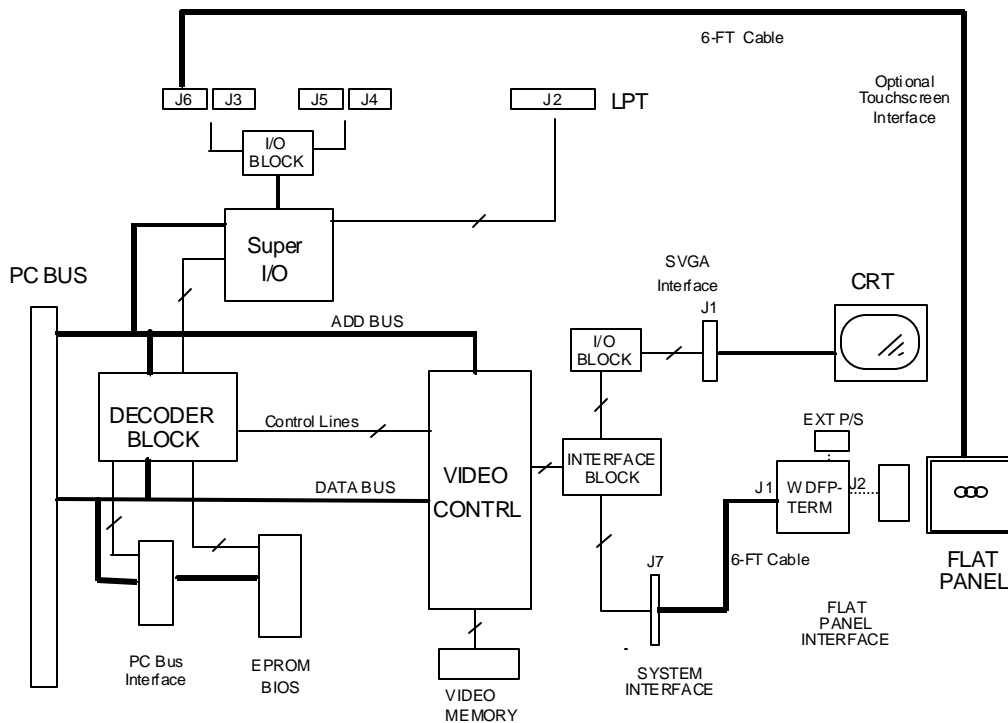

WDFPKit Block Diagram

The Block Diagram consists of the following components:

1. PC Bus interface
2. Decoder Block
3. Video Controller Block and Memory
4. Super I/O Block
5. BIOS EPROM
6. Flat panel interface
7. Super VGA interface
8. COM A serial ports
9. COM B serial ports
10. LPT parallel port

The PC bus interface section consists of:

- 16-bit ISA connectors

- De-coupling capacitors for incoming power and all IC's

- A bi-directional buffer chip, controlled by on-board circuitry directing the flow of the lower 8 bits of the data bus

- Termination of clock signals.

The decoder block consists primarily of two 22V10 PALs which decode the serial and parallel addressing of the ports, perform the chip selection of the EPROM, directs the flow of the PC bus interface and drives the access LED.

The video controller block and memory consists of a CMOS VLSI device that drives flat panel displays and standard CRTs with 1 Mb of video RAM. It is fully backward compatible with previous video standards including MDA, EGA, and CGA.

The super I/O block consists primarily of a 16C552 device, which allow servicing of two serial I/O ports simultaneously, and includes one bi-directional parallel port with read-back capability. Each serial port contains a 16-byte FIFO on both transmit and receive buffers.

The default BIOS EPROM is a 1MB x 8 device, which contains the operating parameters of the WDFPCard.

The flat panel interface block consists of the circuitry, cables and components required to successfully drive a multitude of displays. This block requires a WDFPTerm board connected via a SCSI-2 type cable to the WDFPCard in order to function.

The SVGA interface block consists of driver devices, termination techniques and a cable interface to a CRT in order to function.

The COM and LPT ports are driven directly via the super I/O chip. Strapping fields may be set to customize virtually any system installation.

4.1 WDFPKit Memory Map

The VGA occupies memory from A0000H to BFFFFH depending on the mode, as shown in the following figure. These addresses are the same as defined in the PC/AT. Address ranges listed as "not used" respond to memory reads and writes, but are not used by the video mode. Address ranges not identified do not respond to memory reads or writes.

A0000			Mode 13	Mode 14	Modes 15 & 16	Modes 17 & 18	Mode 19
A1F40			not used	not used			
A3E80							
A6D60					not used		
A9600						not used	
AFA00							not used
B0000							
B8000	Modes 0-3	Modes 4-6					
B8FA0	not used	even scans					
B9F40		not used					
BA000		Modes 4-6 odd scans					
BBF40		not used					
BFFFF							

WDFPKit Memory Map

4.2 WDFPKit I/O Map

The WDFPKit I/O map is listed in the following table.

Address	Function
102	VGA Enable Register
278-27F	LPT2
2E8-2EF	COM4
2F8-2FF	COM2
378-37F	LPT1
3E8-3FF	COM3
3B0-3BB	Monochrome Adapter (VGA)
3C0-3CF	VGA
3D0-3DF	Color Graphic Adapter (VGA)
3F8-3FF	COM1
550-55F	Flash Programming Voltage
760-767	Page Select

WDFPKit I/O Map

Note:

LPT1 is not supported on WDFPCard Revision B.

4.3 WDFPKit Interrupt Assignments

The WDFPKit interrupts are listed in the following table.

Interrupt	Function	Software Vector
3	COM port B Default	BH
4	COM port A Default	CH
5	LPT port Alternate	DH
7	LPT port Default	FH
11	COM port Alternate	73H
12	COM port Alternate	74H
15	COM port Alternate	77H

WDFPKit Interrupt Assignments

4.4 Flash Programming Voltage port

The programming voltage for Flash memory may be turned on or off by outputting to the Flash programming voltage port.

Bit	Function
7-1	Reserved
0	0 = Programming Voltage Disabled
	1 = Programming Voltage Enabled

Flash Programming Voltage Port

4.5 Installation

If you have not yet configured your WDFPKit for your specific application, please refer to Section 2.0. The following section details the steps required for proper system installation.

4.5.1 WDFPCard Installation

Locate an available 16-bit slot in your computer system, plug in your configured WDFPCard and inspect for a firm fit. Screw the mounting bracket down securely to the chassis. Attach all required interface cables to the WDFPCard and examine for a good solid connection.

4.5.2 WDFPTerm Board Installation

The WDFPTerm board has been designed to mount directly to the sheet metal housing via four #6-32 mounting screws located in the corners of the board. For the mechanical dimensions of the board and mounting hole locations, please refer to section 6.5. Attach all required interface cables to the WDFPTerm board and examine for a good solid connection.

(This page intentionally left blank)

5. SOFTWARE OPERATION

The following section details the software parameters of the WDFPKit.

5.1 Flash Programming Voltage Enable/Disable

Flash programming voltage may be turned on and off by using the Flash programming voltage port. The Flash programming voltage is enabled by outputting a 1 to port 550H.

Flash programming algorithms vary between chip manufacturers and can become quite involved. They can cause damage to the Flash EPROM if programmed or erased improperly. Computer Dynamics provides a separate utility (ROMDISK.EXE) which will image a floppy diskette onto a Flash EPROM. This utility is part of the ROM Tools package. Contact Computer Dynamics for more information.

```
*****
; WDFPKit Flash programming voltage Enable
;
; This source code may be used in applications using the
; Computer Dynamics WDFPKit
;
; (c) Lines Unlimited 1989
;
*****

Flash_port      EQU    550H
Flash_ENABLE    EQU    1

CODE    SEGMENT PARA PUBLIC

; Enable Flash programming voltage

port    mov     dx, Flash_port      ; write enable value to the Flash programming
        mov     al, Flash_ENABLE
        out    dx,al

CODE ENDS

END
```

The Flash programming voltage is disabled by outputting a 0 to port 550H.

```
*****
; WDFPKit Flash programming voltage Enable
;
; This source code may be used in applications using the
; Computer Dynamics WDFPKit
;
; (c) Lines Unlimited 1989
;
*****

Flash_port      EQU    550H
Flash_DISABLE   EQU    0
```

```

CODE    SEGMENT PARA PUBLIC

; Enable Flash programming voltage

        mov     dx, Flash_port          ; write disable value to the Flash programming
port
        mov     al, Flash_ENABLE

        out     dx,al

CODE ENDS
        END

```

5.2 Dither Support for Color TFT Flat Panel Displays

Standard VGA video uses a Digital to Analog Converter (DAC), to generate the color signal on an analog monitor. This DAC contains 256 registers. Each register contains a color formula comprised of 6 bits red, 6 bits green, and 6 bits blue. The specific values contained in each register are then used to drive the analog outputs to the monitor.

Since TFT displays are digital, the WDFPKit's video controller implements a "digital DAC". The front end of the DAC is the same as the standard DAC, but the output is provided in different digital formats suitable to driving various types of panels. In addition, many of the standard color TFT LCD displays are 9-bit interface (3 bits red, 3 bits green, 3 bits blue). This means that the internal 6-bits-per-color in each DAC register must be cut down to 3-bits-per-color to drive the panel. The most obvious effect of this color loss is visible in an image in which an area consists of a single color that progresses from very light to very dark. In this type of picture you will be able to see "color bands" instead of smooth transitions from light to dark.

To minimize the effect of the digital interface, the WDFPKit has the capability of dithering. Dithering is a process where specific pixels or groups of pixels are mapped to various intensities and patterns at the video controller level. Depending on the desired 6-bits-per-color in the DAC, the resulting 3-bits-per-color from the controller is constantly modified in real time to give the effect of the desired color. This is somewhat similar to flashing the colors red and white on the screen. If the colors are flashed fast enough, the human eye will interpret them as pink.

5.2.1 The Dither TSR

The WDFPKit is pre-configured with the optimum dither method for flicker-free operation in the DOS environment. However, the WDFPKit Samples and Utilities Diskette comes with a program, DITHER.EXE, that allows the customer to change the dither method or to disable it if desired.

The command line is as follows:

Usage: **dither** [0-6] | [I] | [U]

With no argument it reports the current dither mode

```

0          Read Current Dither Settings( same as with no argument)
1          2 Frame - 27K Color Dithering
2          2 Frame - 180K Color Dithering
3          2 & 3 Frame - 256K Color Dithering
4          NO Dither - 512 True Colors

```

```
5          NO Dither - 512 True Colors
6          Space Dithering - 27K Colors
I\U      Install\Unload TSR
```

As a TSR, [SHIFT-ALT-F1] through [SHIFT-ALT-F6] perform the same functions as the command line options 1 through 6. [SHIFT-ALT-R] will display the current dither mode if in text modes 3 or 7. Otherwise it will be ignored.

The dither program has two modes of operation: 1) command line operation, and 2) TSR operation. When executed from the command line, the change is immediate and remains in effect until the system is re-booted or until dither is executed again with a different option. Below are some examples of using dither as a command line utility.

```
dither -0          read current dither mode
dither -4          disable dithering
dither -5          disable dithering (mode 5 is the same as mode 4)
dither -6          space dithering - 27K colors
dither -? or dither /h  help - displays a usage similar to that shown above.
```

Dither can also be installed as a TSR. This is done by typing:

```
dither -i
```

To unload the TSR simply type:

```
dither -u
```

When installed as a TSR there are 8 hot keys. They are [ALT-SHIFT-F1] through [ALT-SHIFT-F6] and [ALT-SHIFT-R]. [ALT-SHIFT-F1] through [ALT-SHIFT-F6] have the same effect as typing dither -1 through dither -6. They simply set the specified mode. [ALT-SHIFT-R] has the same effect as dither -0 if in text modes 3 or 7, otherwise it is ignored. The TSR capability allows the customer to load an application and then determine the most appropriate dither option without having to drop out to the command line between each dither mode change.

Note:

Dither TSR will not function on the Windows desktop. However, it can be executed as a command line utility from a full screen DOS window under Windows. Also any dither mode that is set prior to starting Windows will remain in effect during Windows unless it is changed in a full screen DOS window as stated earlier.

To determine the default dither mode for your system, power up the WDFPKit unit. Then run dither -0. Dither.exe can be placed in the AUTOEXEC.BAT file if the default dither mode is not acceptable in your environment.

5.3 FVBIOS

There are times when the only part of the BIOS ROM that needs changing or updating is the video BIOS portion. For such cases a utility has been developed called FVBIOS. This utility takes only a video BIOS image and updates a current BIOS Flash ROM with the video BIOS. The command line is:

```
FVBIOS <image file> [f1 | f2]
```

where:	f1	Force SBC-486DX	(486SX / 486DX / 486DX/2)
	f2	Force SBC-SXE/SBC-486	(386SX / 486SLC)

Normally the only command line parameter needed is the input filename. FVBIOS will autodetect the type of Computer Dynamics WDFPKit board on which it is running. If CDI Extensions have been strapped out, FVBIOS will not be able to tell which board it is on, autodetection logic will fail and FVBIOS will prompt the user to specify the appropriate board type from a choice list. If the user has CDI Extensions strapped out and does not wish to be prompted, the board type can be "forced" on the FVBIOS command line.

Note:

The WDFPKit comes with a standard EPROM BIOS. The FVBIOS utility requires an optional Flash BIOS and the WDFPKit must be restrapped for Flash BIOS support prior to using this utility.

5.3.1 Interrupt 10H Functions - Video Services

The INT 10 software interrupt will handle all standard video functions. The following outlines the video services in more detail with their corresponding register entry values:

AH = 00 **Set video mode**
 AL Mode value - Standard VGA Modes - see table below

Mode# Hex	Type	Colors	Alpha	Resolution	Font	Clock (MHz)	HSync (KHz)	VSync (Hz)	Memory (Min.)	Buffer Start	Page
0,1	A/N	16/256K	40x25	320x200	8x8	25.175	31.55	70.3	256K	B8000	8
0,1*	A/N	16/256K	40x25	320x350	8X14	25.175	31.55	70.3	256K	B8000	8
0,1**	A/N	16/256K	40x25	360x400	9x16	28.322	31.34	69.8	256K	B8000	8
2,3	A/N	16/256K	80x25	640x200	8x8	25.175	31.55	70.3	256K	B8000	8
2,3*	A/N	16/256K	80x25	640x350	8X14	25.175	31.55	70.3	256K	B8000	8
2,3**	A/N	16/256K	80x25	720x400	9x16	28.322	31.34	69.8	256K	B8000	8
4,5	APA	4/256K	40x25	320x200	8x8	25.175	31.55	70.3	256K	B8000	1
6	APA	2/256K	80x25	640x200	8x8	25.175	31.55	70.3	256K	B8000	1
7	A/N	MONO	80x25	720x350	9x14	28.322	31.34	69.8	256K	B8000	8
7*	A/N	MONO	80x25	720x400	9x16	28.322	31.34	69.8	256K	B8000	8
D	APA	16/256	40x25	320x200	8x8	25.175	31.55	70.3	256K	A0000	8
E	APA	16/256K	80x25	640x200	8x8	25.175	31.55	70.3	256K	A0000	4
F	APA	MONO	80x25	640x350	8X14	25.175	31.55	70.3	256K	A0000	2
10	APA	16/256K	80x25	640x350	8X14	25.175	31.55	70.3	256K	A0000	2
11	APA	2/256K	80x30	640x480	8x16	25.175	31.55	60.1	256K	A0000	1
12	APA	16/256K	80x30	640x480	8x16	25.175	31.55	60.1	256K	A0000	1
13	APA	256/256K	40x25	320x200	8x8	25.175	31.55	70.3	256K	A0000	1

Note:

For Modes 3 and 7, 8-dot fonts are used when driving a panel.

AH = 01 **Set cursor type (start and end)**

CL Cursor end line

CH Cursor start line

AH = 02 **Set cursor position**

BH Page to set cursor

DL Character column position

DH Character row position

AH = 03 Get cursor position of page
 BH Page to return cursor
Exit:
 DL Character column position
 DH Character row position
 CL Cursor end line
 CH Cursor start line

AH = 04 Return light pen position
Exit:
 DL Char column of light pen
 DH Char row of light pen
 CH Raster line
 BX Pixel column
 AH Light pen trigger (1 pressed)

AH = 05 Change displayed (active) page
 AL Page number to display

AH = 06 Scroll active page up
 CL Column of scroll upper left
 CH Row of scroll upper left
 DL Column of scroll lower right
 DH Row of scroll lower right
 BH Attribute for blanked space
 AL Number of lines to scroll

AH = 07 Scroll active page down
 CL Column of scroll upper left
 CH Row of scroll upper left
 DL Column of scroll lower right
 DH Row of scroll lower right
 BH Attribute for blanked space
 AL Number of lines to scroll

AH = 08 Read character and attribute
 BH Video page to read character
Exit:
 AL Character

AH = 09 Write character and attribute
 AL Character to write
 BL Character attribute (alpha)
 Character color (graphics)
 BH Page to write character
 CX Count of characters to write

AH = 0A Write character at cursor
 BH Page to write character
 AL Character to write
 CX Count of characters to write

AH = 0B Write color palette
 BL Color value for palette

BH	Palette color ID (01)
AH = 0C	Write graphics pixel
AL	Color value for pixel (XORed if bit7=1)
CX	Column to write pixel
DX	Row to write pixel
AH = 0D	Read graphics pixel
CX	Column to read pixel
DX	Row to read pixel
Exit:	
AL	Value of pixel read
AH = 0E	Teletype write character
AL	Character to write
BL	Foreground color (graphics only)
AH = 0F	Return Current Video Parameters
Exit:	
AL	Current video mode
AH	Number of character columns
BH	Active page
AH = 13	Write string
ES:BP	Pointer to string
CX	Length of string to display
DH	Character row for display
DL	Character column for display
BL	Display attribute
AL	Write string mode
	0 Chars only, no cursor update
	1 Chars only, update cursor
	2 Char, Attrib, no cursor update
	3 Char, Attrib, update cursor

5.3.2 Interrupt 10H Functions - Western Digital Paradise Extensions

In addition to the standard video functions, the Computer Dynamics WDFPKit-486DX family provides Western Digital Paradise Super VGA Enhancements via INT 10 BIOS calls.

AH = 00	Set video mode
AL	= Western Digital Mode number, per tables below

VESA VBE-Compliant Super VGA Modes

VESA Mode# (Hex)	WD Mode	Type	Colors	Alpha	Resolution	Font	Memory (Min.)	Buffer Start	Page
101	5F	APA	256/256K	80x30	640x480	8x16	512K	A0000	1
102	58/6A	APA	16/256K	100x75	800x600	8x8	256K	A0000	1
103	5C	APA	256/256K	700x75	800x600	8x8	512K	A0000	1
104	5D	APA	16/256K	128x48	1024x768	8x16	512K	A0000	1
105	60	APA	256/256K	128x48	1024x768	8x16	1M	A0000	1
109	55	A/N	16/256K	132x25	1056x400	8x16	256K	B8000	4
10A	54	A/N	16/256K	132x43	1056x344	9x9	256K	B8000	2
10D	68	APA	32,768	40x25	320x200	8x8	256K	A0000	1
10E	78	APA	65,536	40x25	320x200	8x8	256K	A0000	1
110	62	APA	32,768	80x30	640x480	8x16	1M	A0000	1
111	72	APA	65,536	80x30	640x480	8x16	1M	A0000	1

132 Column Modes (Supported on CRT only)

Mode# (Hex)	Type	Colors	Alpha	Resolution	Font	Clock (MHz)	HSync (KHz)	VSync (Hz)	Memory (Min.)	Buffer Start	Page
54	A/N	16/256K	132x43	1056x344	9x9	44.9	31.06-	69.2+	256K	B8000	2
55	A/N	16/256K	132x25	1056x400	8x16	44.9	31.06-	69.2+	256K	B8000	4

640x480x256 Color Modes

Mode# (Hex)	Type	Colors	Alpha	Resolution	Font	Clock (MHz)	HSync (KHz)	VSync (Hz)	Memory (Min.)	Buffer Start	Page
5F	APA	256/256K	80x30	640x480	8x16	25.175	31.55-	60.1-	512K	A0000	1

800x600 modes (Supported on CRT only)

Mode# (Hex)	Type	Colors	Alpha	Resolution	Font	Clock (MHz)	HSync (KHz)	VSync (Hz)	Memory (Min.)	Buffer Start	Page
58/6A	APA	16/256K	100x75	800x600	8x8	36.0	35.12-	56.2-	256K	A0000	1
58/6A	APA	16/256K	100x75	800x600	8x8	40.0	37.84+	60.3+	256K	A0000	1
58/6A	APA	16/256K	100x75	800x600	8x8	50.0	47.67+	71.7+	256K	A0000	1
5C	APA	256/256K	100x75	800x600	8x8	36.0	35.12-	56.2-	512K	A0000	1
5C	APA	256/256K	100x75	800x600	8x8	40.0	37.84+	60.3+	512K	A0000	1
5C	APA	256/256K	100x75	800x600	8x8	50.0	47.67+	71.8+	1M	A0000	1

1024x768 modes

Mode# (Hex)	Type	Colors	Alpha	Resolution	Font	Clock (MHz)	HSync (KHz)	VSync (Hz)	Memory (Min.)	Buffer Start	Page
5D	APA	16/256K	128X48	1024X768	8X16	44.9	35.6+	87.1+	512K	A0000	1
5D	APA	16/256K	128X48	1024X768	8X16	65.0	48.37-	60.0-	512K	A0000	1
60 ⁽¹⁾	APA	256/256K	128X48	1024X768	8X16	44.9	35.6+	87.1+	1M	A0000	1
60 ⁽¹⁾	APA	256/256K	128X48	1024X768	8X16	65.0	48.37-	60.0-	1M	A0000	1

(1) This mode has an alternate mode number of 30 for use in environments which have a conflicting Mode 60.

32K Color modes

Mode# (Hex)	Type	Colors	Alpha	Resolution	Font	Clock (MHz)	HSync (KHz)	VSync (Hz)	Memory (Min.)	Buffer Start	Page
62 ⁽¹⁾	APA	32,768	80x30	640x480	8x16	25.2	31.50-	70.29	1M	A0000	1
68 ⁽¹⁾	APA	32,768	40x25	320x200	8x8	25.2	31.60-	70.2+	256K	A0000	1

(1) This mode has an alternate mode number of 32 for use in environments which have a conflicting Mode 62.

64K Color modes

Mode# (Hex)	Type	Colors	Alpha	Resolution	Font	Clock (MHz)	HSync (KHz)	VSync (Hz)	Memory (Min.)	Buffer Start	Page
72	APA	65,536	80x30	640x480	8x16	25.2	31.50-	70.29	1M	A0000	1
78	APA	65,536	40x25	320x200	8x8	25.2	31.60-	70.2+	256K	A0000	1

Additional Video services are supported via a "Gateway Function" (identified by ax=7F7FH).

Note:

All numbers shown in the BIOS calls are HEX.

AX = 7F7F

BH = 2 **Return Special Status Info**

Returns: CH = Total display memory (VRAM) in 64K units

CL = Display memory (VRAM) unused

AX = 7F7F

BX = 4101 **Toggle Auto-Centering ON/OFF**

Note:

Not available when Vertical Expansion is enabled. Vertical Expansion is the default setting for most WDFPKit-486DX flat panel products with 480 vertical lines or greater. Some panels less than 480 lines high are implemented with Vertical Expansion disabled.

AX = 7F7F
BX = 4102 **Toggle Vertical Expansion ON/OFF**

Note:

Text modes and graphics modes use different hardware algorithms for expanding to fill the screens. Text modes use "enhanced vertical expansion" which only expands the lines between the text characters and so the text characters do not look choppy like most flat panel displays.

AX = 7F7F
BX = 4103 **Toggle Enhanced Vertical Expansion Type**
Types available: Expand three lines below each text row.
Expand one line above and two lines below each text row.

Note:

Enhanced Vertical expansion is only available in text modes. A different hardware algorithm is used in graphics modes.

AX = 7F7F
BX = 4104 **Three Way Display Toggle: flat panel ☺ CRT ☺ Simultaneous**

Note:

During Three-way Display Switching, the switch from CRT-only to Simultaneous is inhibited if the current Video Mode is a high-resolution mode which is not supported on the flat panel.

AX = 7F7F
BX = 4105 **Switch to CRT**

Note:

This BIOS call may clear the video memory when using a split screen (dual screen) panel.

AX = 7F7F
BX = 4106 **Switch to LCD**

Note:

This BIOS call may clear the video memory when using a split screen (dual screen) panel.

AX = 7F7F
BX = 4107 **Toggle Between LCD/CRT; No Mode Set (VGA Mode Only)**

AX = 7F7F
BX = 4108 **Toggle Between Simultaneous/Non-Simultaneous Display (VGA Mode Only)**

AX = 7F7F
BX = 410A **Toggle between Normal/Reverse Video for Text/Graphics Modes.**

Note:

This toggling feature is for MONO LCD only and has the following sequence: Text Reverse and Graphics Normal, then Text Normal and Graphics Normal, then Text Reverse and Graphics Reverse.

AX = 7F7F

BX = 410B Toggle between 32-Bit and 16-Bit Memory Data Path.

AX = 7F7F

BX = 410D Switch To Simultaneous mode.

Note:

This BIOS call may clear the video memory when using a split screen (dual screen) panel.

AX = 7F7F

BX = 4200 Get Extended Information

Returns:

BX = Status Information

CX = Status Information (see below)

STATUS BITS	BX	CX
0	00 = No CRT Attached 01 = Color CRT Attached 10 = Mono CRT Attached 11 = Reserved	Reserved
1		
2	0 = Display is CRT 1 = Display is LCD	0 = 32-bit memory data path 1 = 16-bit memory data path
3	0 = Auto Center is On 1 = Auto Center is Off	Reserved
4	00 = Graphics Normal - Text Reverse 01 = Graphics Normal - Text Normal 10 = Graphics Reverse - Text Reverse 11 = Reserved	
5		
6	0 = Vertical Expansion is On 1 = Vertical Expansion is Off	Memory Configuration 000 = Reserved 001 = Reserved 100 = 256Kx16x2 101 = 256Kx16x1 111 = Reserved
7	Reserved	
8	00 = 800x600 @ 56Hz 01 = 800x600 @ 60Hz 10 = 800x600 @ 72Hz 11 = 800x600x16 @ 72Hz & 800x600x256 @ 72Hz	
9		Reserved
10	00 = 1024x768x16 Interlaced 01 = 1024x768x16 @ 60Hz 10 = Reserved 11 = Reserved	
11		
12	00 = 1024x768x256 Interlaced 01 = 1024x768x256 @ 60Hz 10 = Reserved 11 = Reserved	
13		0 = AT Bus 1 = Local Bus
14	0 = Non-simultaneous Display 1 = Simultaneous Display	Reserved
15	Reserved	0 = 90c24 1 = 90c24A

AX = 7F7F
 BX = 4201 **Set Extended Information**

CH = Status Information

STATUS BITS	CH
0	00 = 800x600 @ 56Hz 01 = 800x600 @ 60Hz 10 = 800x600 @ 72Hz 11 = 800x600x16 @ 72Hz & 800x600x256 @ 72Hz
1	
2	00 = 1024x768x16 Interlaced 01 = 1024x768x16 @ 60Hz 10 = 1024x768x16 @ 70Hz 11 = 1024x768x16 @ 72Hz
3	
4	00 = 1024x768x256 Interlaced 01 = 1024x768x256 @ 60Hz 10 = 1024x768x256 @ 70Hz 11 = 1024x768x256 @ 72Hz
5	
6	Reserved
7	

AX = 7F7F

BX = 4700 Do Monitor Detection

Returns: BL = 0 - No Monitor
BL = 1 - Color Monitor
BL = 2 - Mono Monitor

AX = 7F7F

BH = 48 Set Power Down Status

BL = 0 - System Power-Down Mode

CH = DRAM refresh option
0=DRAM self refresh
1=CAS before RAS refresh
2=CKIN / PR71
3=32 KHz pass-through

BL = 1 - Display Idle Mode

CH = DRAM refresh option
0=DRAM self refresh
1=CAS before RAS refresh

BL = 2 - General Power-Down Mode

CL = EXT Clock Divide Value

BL = 3 - General Power-Down Mode

CL = INT Clock Divide Value

BL = 4 - Deep Sleep Mode (save registers)

CH = DRAM refresh option
ES:DX = 1020 byte buffer

BL = 5 - Deep Sleep Mode (restore registers)

ES:DX = 1020 byte buffer

BL = 6 - Save Display Memory

CX = 64K display memory bank

BL = 7 - Restore Display Memory

CX = 64K display memory bank
 AX = 7F7F
BH = 49 To-Suspend

 AX = 7F7F
BH = 4A From-Suspend

 AX = 7F7F
BH = 60 Return BIOS Status Info
Returns: AX = Offset to date_time
 CX = offset to part_no/version
 BP = Segment of BIOS
 DI = Offset to BIOS Internal Tables

5.3.3 Interrupt 11H Functions - Return System Information

Return the equipment installed determined by the BIOS power on diagnostics.

Interrupt 11 Functions

Exit:

AX	Equipment information
0	Diskette drives attached
1	Math coprocessor installed
2,3	Planer RAM size in 16k increments
4,5	Initial video mode
	00 - Unused
	01 - 40x25
	10 - 80x25
	11 - Monochrome
6,7	Diskette drives
	00 - 1 drive
	01 - 2 drives
	10 - 3 drives
	11 - 4 drives
8	Not used
9-11	Number of serial adapters
12	Game Adapter installed
13	Not used
14,15	Number of parallel adapters

5.3.4 Interrupt 12H Functions - Return System Memory Size

Return the amount of system memory determined during the power on diagnostics. The value returned is expressed in kb.

Interrupt 12 Functions

Exit:
AX Number of 1k memory blocks

5.3.5 Interrupt 14H Functions - Serial Services

The INT 14 software interrupt will handle serial I/O function requests. This code will use the AH register to decide which of the interrupt 14 functions are to be invoked. The following outlines the serial communication services:

Interrupt 14 Functions

AH = 00 Set communication parameters

AL Init parameters
 Bit 1,0 = 10 7 data bits
 11 8 data bits
 Bit 2 = 0 1 stop bit
 1 2 stop bits
 Bit 4,3 = 00 No parity
 10 No parity
 01 Odd parity
 11 Even parity
 Bit 7-5 = 000 110 Baud-417 divisor
 001 150 Baud-300 divisor
 010 300 Baud-180 divisor
 011 600 Baud-0C0 divisor
 100 1200 Baud-060 divisor
 101 2400 Baud-030 divisor
 110 4800 Baud-018 divisor
 111 9600 Baud-00C divisor

DX serial port
Exit:
AL Modem status
AH Line status (Bit 7 - timeout)

AH = 01 Transmit character

AL Character to transmit
DX serial port
Exit:
AH Line status (Bit 7 - timeout)

AH = 02 Receive character

DX serial port
Exit:
AL Character received
AH Status (Bit 7 - timeout)

AH = 03 Return status

DX serial port
Exit:
AL Modem status
AH Line status (Bit 7 - timeout)

Bit Modem Status
0 Delta clear to send

1	Delta data set ready
2	Trailing edge ring indicator
3	Delta (RLSD)
4	Clear to send
5	Data set ready
6	Ring indicator
7	Received line signal detect

Bit	Line Status
0	Data ready
1	overrun error
2	Parity error
3	Framing error
4	Break detect
5	Trans holding register empty
6	Trans shift register empty
7	Time out error

5.3.6 Interrupt 15H Functions - Miscellaneous Hardware Services

The INT 15 software interrupt will handle a variety of functions, which are particular to the hardware. These include functions for multi-tasking, joystick functions, and extended memory functions. This code will use the AH register to decide which of the interrupt 15 functions are to be invoked. The following outlines the miscellaneous services in more detail with their corresponding register entry values:

Interrupt 15 Functions

AH = 00-7F Cassette functions

Exit:	
AH	86
C	Set

AH = 80 Device open

BX	Device identifier
CX	Process identifier

AH = 81 Device close

BX	Device identifier
CX	Process identifier

AH = 82 Program termination

BX	Device identifier
----	-------------------

AH = 83 Event wait

AL	00 Set event timer
ES:BX	Pointer to post byte
CXDX	Microseconds before post
AL	01 Cancel event timer

AH = 84 Joystick support

DL	00 Read switch settings
Exit:	
AL	Switch settings

DL 01 Return resistive inputs

Exit:

AX Resistive input bit 0
BX Resistive input bit 1
CX Resistive input bit 2
DX Resistive input bit 3

AH = 85 System request key pressed

AL 00 System request key pressed
AL 01 System request key released

AH = 86 Wait microseconds

CX:DX Number of microseconds to wait

AH = 87 Move block

CX Number of words to move
ES:SI Pointer to global descriptor table

AH = 88 Extended memory size

Exit:

AX Amount of extended memory in kb

AH = 89 Enter protected mode

ES:SI Pointer to descriptor
BH Offset into IDT for IRQ 00-07
BL Offset into IDT for IRQ 08-0F

AH = 90 Device busy

AL Type code

AH = 91 Interrupt completion

AL Type code

AH = C0 Return system parameters

Exit:

ES:BX Pointer to configuration table
AH 00

5.3.7 Interrupt 17H Functions - Parallel Printer Services

The INT 17 software interrupt will handle the parallel printer I/O function requests. This code will use the AH register to decide which of the interrupt 17 functions is to be invoked. The following outlines the printer services:

Interrupt 17 Functions

AH = 00 Print character

AL Character to print
DX Printer port

Exit:

AH Status

AH = 01 Initialize printer port

DX Printer port

Exit:

AH Status

AH = 02 Return printer status

DX Printer port

Exit:

AH Status

Bit	Status
0	Time out
1	Reserved
2	Reserved
3	I/O error
4	Selected
5	Out of paper
6	Acknowledge
7	Not busy

(This page intentionally left blank)

6. REFERENCE SECTION

6.1 Additional Reading

IBM PC Technical Reference, IBM Corp., 1983. - Complete reference to the PC. There are versions for both the PC/XT and PC/AT.

Microprocessor and Peripheral Handbook, Volume 1 - Microprocessor, Intel, 1989. This volume contains register definitions for the parts duplicated in the HT-22.

The Programmer's PC Sourcebook, Thom Hogan, Microsoft Press, 1988. This volume contains many tables of useful information on the PC family. It is very handy for the assembly language programmer.

The Peter Norton Programmer's Guide to the IBM PC, Peter Norton, Microsoft Press, 1985. This book is an excellent introduction to the logical organization of the PC family. It highlights differences between different versions.

Microsoft MS-DOS User's Guide and User's Reference, Microsoft, 1988. This volume is included with each purchase of MS-DOS. It will explain DOS commands and some important operations such as formatting.

Programmer's Guide to the EGA and VGA Cards, Richard F. Ferraro, Addison-Wesley Publishing Company, 1988. This volume explains in good detail the function and use of the VGA registers and BIOS calls.

C Programmers Guide to Serial Communications, Joe Campbell, Howard W. Sams & Company, 1987. A complete reference to programming asynchronous serial communications.

6.2 WDFPKit I/O Options

The WDFPKit has a 100% compatible, parallel printer port. That means that all output pins can be read back at the pin. Additionally, four pins have open collector outputs allowing them to be used as inputs or outputs. Compatibility also means IBM defined connectors, pinouts, port mapping, and logic conventions.

If not used for a parallel printer, the parallel printer port can be used as general-purpose parallel I/O. The outputs can drive LEDs, intelligent LCD displays, motor controllers or higher voltage devices through solid state relays. The input lines can be used to read switches, multiplexed keypads, encoders, or interface to higher voltages through solid state relay racks. The parallel printer port can be used as follows:

- 8 bits output only with read back
- 4 bits open collector outputs which are programmable as input or output with read back
- 4 bits input only
- 1 bit programmable interrupt and readable input

All outputs have read back. Read-back keeps you from having to store the output value in memory when changing individual bits. An input buffer actually senses the level at the output and lets you read it. Unfortunately, if the outputs are heavily loaded, the output voltage may not be within TTL voltage limits causing the read back value to be incorrect. LEDs are current devices and will light up even though the pin is greater than 0.8V. However, the read back buffer may see that pin as a high. In these cases, store a copy of what you output in memory.

The bits are accessed by reading or writing to I/O port locations. The following tables show the I/O port locations and list the connector pins affected. The board has a 26-pin header connector, which is normally cabled to a DB-25 connector. The tables and connector diagrams list both the header and DB-25 connector pin numbers.

	D7	D6	D5	D4	D3	D2	D1	D0
Header Pin Number	17	15	13	11	9	7	5	3
DB-25 Pin Number	9	8	7	6	5	4	3	2

Write Address 378H (Use as outputs only.) Reset Condition: Undetermined

These pins are connected to driver outputs with direct read back via port 378H. Each output can source 2.6 mA and sink 24 mA while maintaining TTL voltage levels. This port is not reset on power-up. External devices must not drive these lines or damage may occur.

	D7	D6	D5	D4	/D3	D2	/D1	/D0	
Header Pin Number				IRQ7 Enable	8	6	2	1	
DB-25 Pin Number				IRQ7 Enable	17	16	14	1	
Reset Condition				0	0	0	0	0	
Write for Input	0	0	0	0	0	1	0	0	= 04H

Write Address 37AH (These pins may be outputs or inputs.)

These four pins are connected to open collector outputs with 4.7k pull-up resistors. Each line can sink about 7 mA while maintaining TTL levels. Each pin is also connected to an input buffer for read back. With the open collector output off, the pin can be used as an input. The drawing at the end of this section illustrates how to use these outputs. Notice that D2 is not inverted.

When D4 is set, an interrupt request #7 (IRQ7) will be generated, at the time pin 10 makes a high-to-low transition. Do not enable the interrupt unless pin 10 is properly driven (pin 10 has no pull-up resistor). The status of pin 10 may be read.

	D7	D6	D5	D4	D3	D2	D1	D0
Header Pin Number	17	15	13	11	9	7	5	3
DB-25 Pin Number	9	8	7	6	5	4	3	2

Read Address 378H

The 8-bit output port 378H may also be read back at the same address. This allows you to read the data you have written. External devices must not drive these lines or damage may occur. To simplify your code, OR this byte with the bits you wish to set.

	D7	D6	D5	D4	/D3	D2	/D1	/D0
Header Pin Number				IRQ7 Enable	8	6	2	1
DB-25 Pin Number				IRQ7 Enable	17	16	14	1

Read Address 37AH (These pins may be outputs or inputs.)

These four pins are connected to open collector outputs with 4.7k pull-up resistors. If the appropriate value is written to the open collector outputs (see the following figure), then the pins may be used as inputs. Switches to ground may be connected directly to these pins since 4.7k pull-up resistors are provided on the board. Notice that some inputs are inverted while D2 is not.

	/D7	D6	D5	D4	D3	D2	/D1	/D0
Header Pin Number	21	19	23	25	4			
DB-25 Pin Number	11	10	12	13	15			

Read Address 379H

These five pins are inputs only and have no internal pull-up resistors. Any device connected to these pins must ensure that the logic level goes to a true low (<0.8V) as well as high (>2.0V). An external pull-up resistor must be connected from the input to +5V when open collector devices or switches are used to ground the input.

	DB-25	Header	Header	DB-25	
*Write 37AH bit /D0	1	1	2	14	*Write 37AH bit /D1
Write 378H bit D0	2	3	4	15	
Write 378H bit D1	3	5	6	16	*Write 37AH bit D2
Write 378H bit D2	4	7	8	17	*Write 37AH bit /D3
Write 378H bit D3	5	9	10	18	Ground
Write 378H bit D4	6	11	12	19	Ground
Write 378H bit D5	7	13	14	20	Ground
Write 378H bit D6	8	15	16	21	Ground
Write 378H bit D7	9	17	18	22	Ground
	10	19	20	23	Ground
	11	21	22	24	Ground
	12	23	24	25	Ground
	13	25	26		

Outputs

* Indicates an open collector output which can also be used as an input.

	DB-25	Header	Header	DB-25	
*Read 37A bit /D0	1	1	2	14	*Read 37AH bit /D1
Read back 378H bit D0	2	3	4	15	Read 379H bit D3
Read back 378H bit D1	3	5	6	16	*Read 37AH bit D2
Read back 378H bit D2	4	7	8	17	*Read 37AH bit /D3
Read back 378H bit D3	5	9	10	18	Ground
Read back 378H bit D4	6	11	12	19	Ground
Read back 378H bit D5	7	13	14	20	Ground
Read back 378H bit D6	8	15	16	21	Ground
Read back 378H bit D7	9	17	18	22	Ground
Read 379H bit D6 /INT	10	19	20	23	Ground
Read 379H bit D7	11	21	22	24	Ground
Read 379H bit D5	12	23	24	25	Ground
Read 379H bit D4	13	25	26		

Inputs

* Indicates an open collector output which can also be used as an input.

6.3 WDFPCard Mating Connectors

Reference Designator	Function	CDI Part Number	Manufacturer's Part Number
J1	VGA Monitor	7CRF0-0020-1600	AMP # 499997-3
J2	LPT port	7CRF0-0020-2600	AMP # 499997-6
J3	COMA RS-422	7CRF0-0020-1000	AMP # 499997-1
J4	COMB RS-422	7CRF0-0020-1000	AMP # 499997-1
J5	COMB RS-232	7CRF0-0020-1000	AMP # 499997-1
J6	COMA RS-232	7CBM0-0020-0800	AMP # 747197-3
J7	System Interface	N/A	AMP # 750681-1
J8	System Interface	N/A	SAMTEC # TCSD-25-S-XX-01

6.4 WDFPTerm Board Mating Connectors

Reference Designator	Function	CDI Part Number	Manufacturer's Part Number
J1	System Interface	N/A	AMP # 750681-1
J2	Panel Interface	7CRF0-0020-2600	AMP 499997-6
J3	External Power	7CRF0-0004-3000	AMP 1-480424-0
J4	Touchscreen Power	7CRF0-2100-0400	MOLEX 22-01-2047
J5	Backlight Power	7CRF0-2100-0400	MOLEX 22-01-2047
J6	Spare Power	7CRF0-2100-0400	MOLEX 22-01-2047
J7	BLDIM Control	7CRF0-0020-1100	AMP 499997-1

6.5 Mechanical Outlines

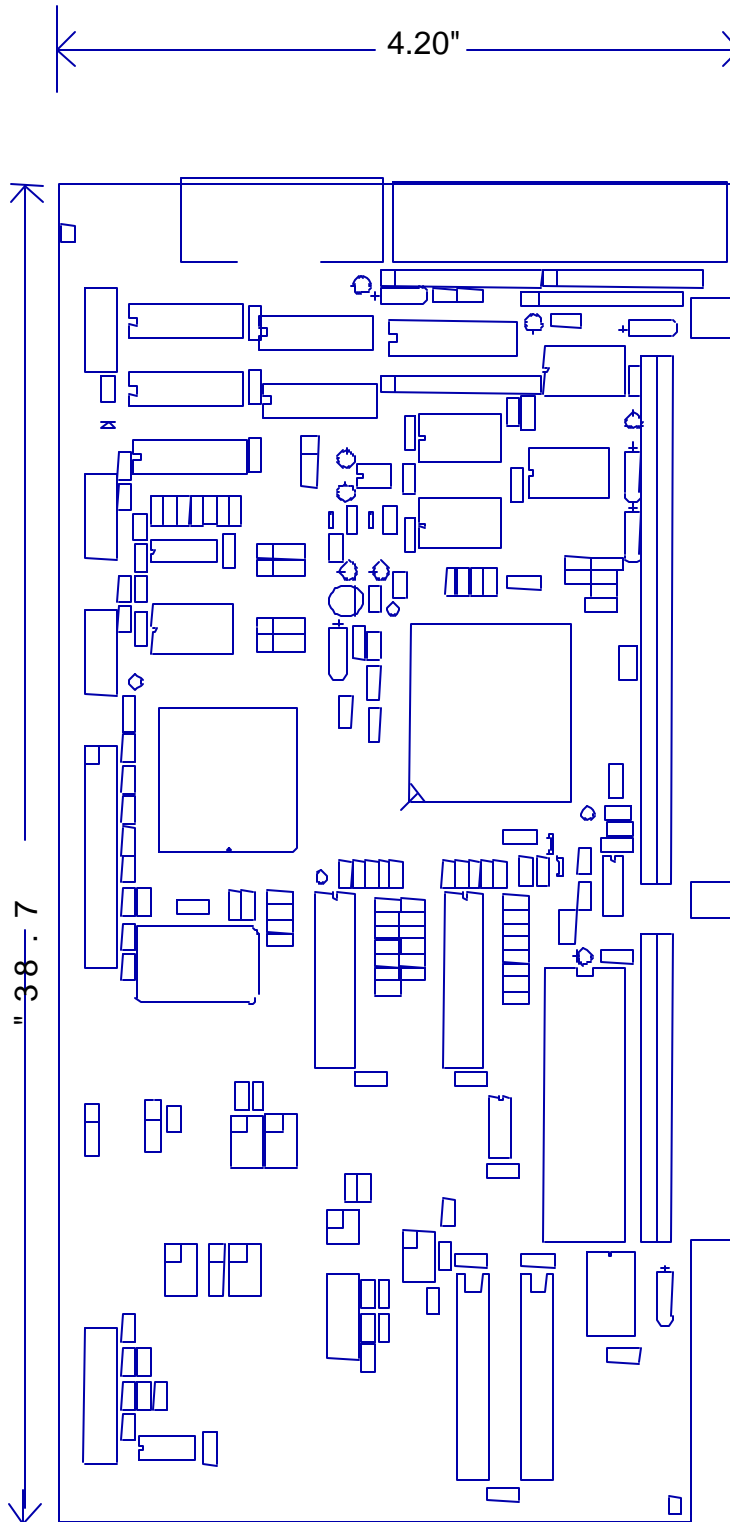

WDFPCard Revision B Mechanical

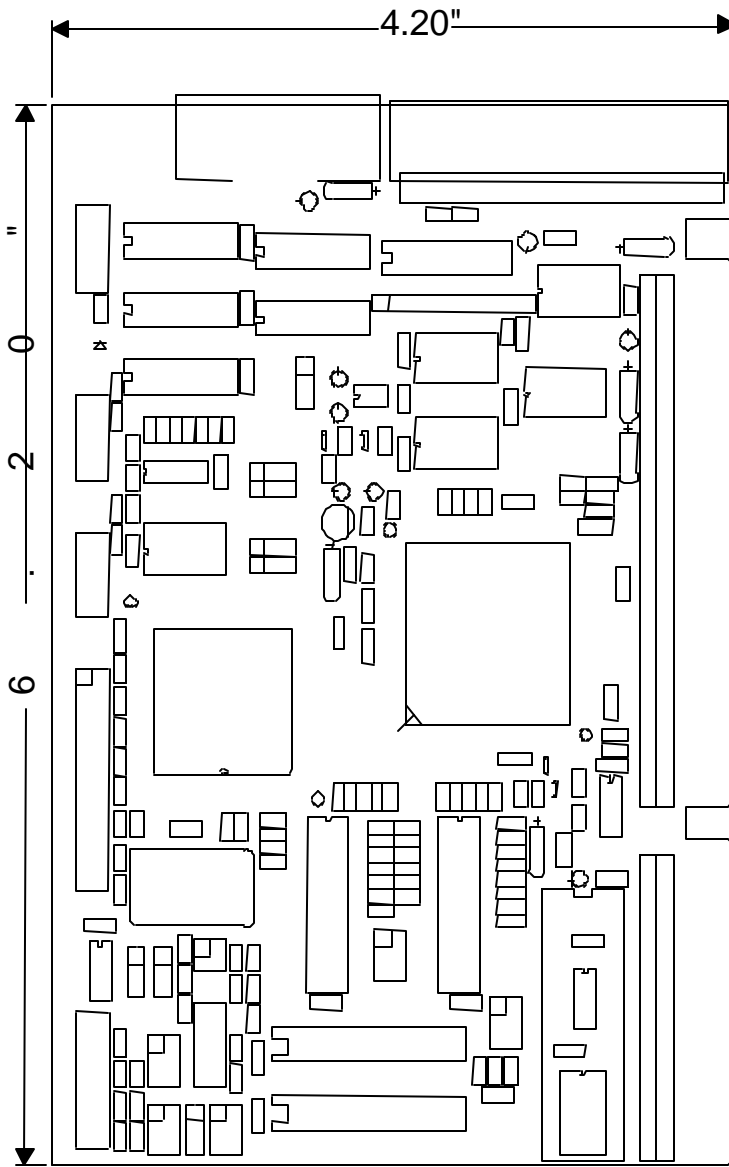

WDFPCard Revision C Mechanical

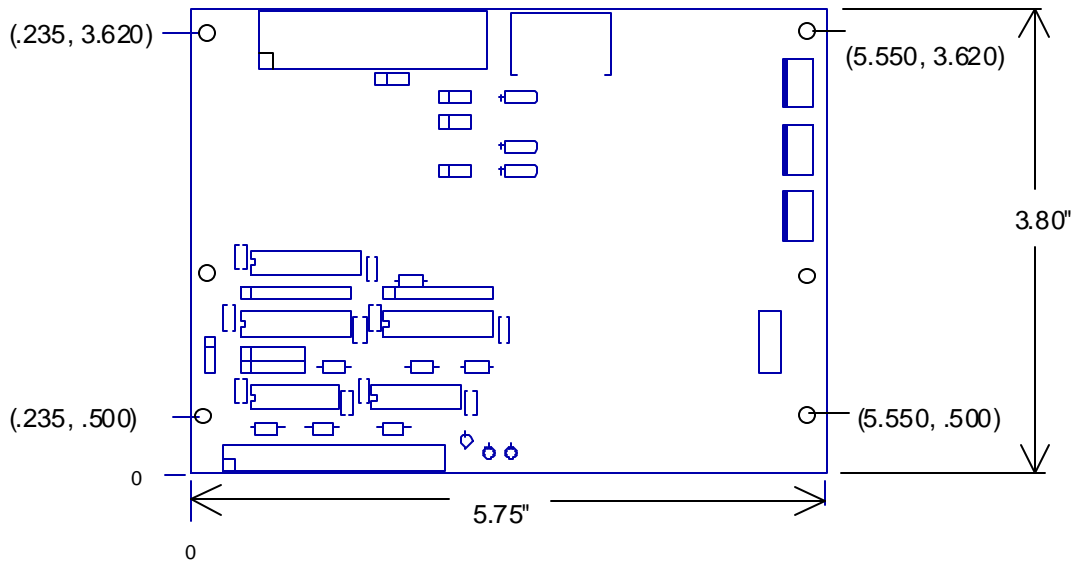

WDFPTerm Board Mechanical

Note:

There are four mounting holes located in the corners of the WDFPTerm board and are designed for #6 hardware. The remaining two holes are designed for supporting panel interface boards available from Computer Dynamics support and should not be used for mounting the WDFPTerm board.

7. Warranty



COMPUTER DYNAMICS INCORPORATED
7640 Pelham Rd., Greenville, SC 29615
Phone: (864) 627-8800

WARRANTY

CDI products are warranted for a period of one year from the date of purchase against all defects in materials and workmanship provided they are properly used and not modified by non-CDI personnel. Subassemblies and items not manufactured by CDI (power supplies, disk drives, etc.) are warranted for the period established by their original manufacturer. CDI will repair or replace the product, provided that it is returned promptly to CDI at the owner's expense. Prior to returning a component or subsystem, the purchaser must obtain a Return Material Authorization number (RMA#) from CDI. All board level products are shipped in an antistatic bag to prevent damage to the electronic components due to electrostatic discharge. Failure to use the bag in shipment will VOID the warranty. No other warranty is expressed or implied.

DISCLAIMER

CDI makes no representation or warranties with respect to the contents hereof and specifically disclaims any implied warranties of merchantability or fitness for any particular purpose. Further, CDI reserves the right to revise the prices or specifications and to make any changes from time to time in the contents hereof without obligation of CDI to notify any person of such revisions or changes.

To Our Customers:

It is our intention to provide you with accurate and useful information about our product. Although the information is correct to the best of our knowledge, we cannot assume responsibility for inaccuracies within the manual.

We request that you inform us of any errors found, areas difficult to understand or suggestions to improve this manual. Please fill out the bottom portion (using additional sheets if necessary) with your comments and return it to CDI.

Thank you.

Name: _____

Computer Dynamics, Inc.

Company: _____

7640 Pelham Rd.

Greenville, S.C. 29615

Phone: (864) 627-8800

Address: _____

Phone: _____

Product Type: _____

Card Serial No. _____

COMMENTS: