

DisplayPac Access™ w/SBC-Max2

Technical Reference Manual

**Copyright 2000
Computer Dynamics, Inc.**

**7640 Pelham Road
Greenville, SC 29615
864-627-8800**

TRADEMARK ACKNOWLEDGMENT

HiQColor™ and TMED™ are trademarks of Intel Corporation (formerly Chips and Technologies, Inc.)

IBM®, Enhanced Graphics Adapter™ and Video Graphics Adapter™ are trademarks of International Business Machines Corporation.

IEEE is a trademark of The Institute Of Electrical And Electronic Engineers, Inc.

MS-DOS™, Windows™, WindowsCE™, Win95™, Win98™ and WinNT™ are trademarks of Microsoft Corporation.

Pentium™, Pentium II™ and Celeron™ are trademarks of Intel Corporation

PhoenixBIOS™ is a trademark of Phoenix Technologies Ltd.

Universal Serial Bus, Specification Copyright Compaq Computer Corporation, Intel Corporation, Microsoft Corporation, NEC Corporation.

VESA® is a registered trademark and VBE™ is a trademark of the Video Electronics Standards Association.

*All other trademarks are the property of their respective holders.

COPYRIGHTS

The information contained in this document is not to be used for other than the purpose, for which this document is furnished by Computer Dynamics, Inc. Nor is this document (in whole or in part) to be reproduced or furnished to third parties or made public without the prior express written permission of Computer Dynamics, Inc.

NOTICE

Neither Computer Dynamics, Inc. nor any of the contributors to this document makes any warranty or representation (expressed or implied) with respect to the accuracy, completeness, or usefulness of the information contained in this document. Computer Dynamics, Inc. assumes no responsibility for liability or damage of any kind which result from the use of the information contained in this document.

The customer should be on notice that many different parties hold patents on products, components, and processes within the personal computer industry. Customers should ensure that their use of the products does not infringe upon any patents. Computer Dynamics, Inc. respects the patent rights of third parties and shall not participate in direct or indirect patent infringement.

REVISION HISTORY

REV	DATE	BY	DESCRIPTION
A-01	5/15/00	R. W. Wilkins	Initial Release

FCC Testing

This subassembly is marketed to be sold to equipment manufacturers for incorporation into systems. This subassembly is not FCC tested. FCC testing is the responsibility of the final equipment manufacturer.

TABLE OF CONTENTS

1	INTRODUCTION	1
1.1	Specifications	1
1.2	System Description	2
1.2.1	Factory ready.....	2
1.2.2	Modular simplicity	2
1.2.3	Rugged Touchscreens	3
1.3	Access Computer Module, Standard	4
1.3.1	Features.....	4
1.4	Access Computer Module, Expanded.....	5
1.4.1	Additional Features.....	5
2	COMMISSIONING PROCEDURES	6
2.1	Mounting Guidelines.....	6
2.2	Installing Access Bezel	6
2.2.1	Completing the Access Installation Process.....	8
2.2.2	Powering Up the Access Computer.....	9
2.2.3	System Test and Initialization.....	9
2.2.4	System Configuration Verification	10
2.3	BIOS Settings.....	10
2.3.1	Setting Up Windows 98 Systems.....	10
2.3.2	Setting Up Windows NT Systems.....	11
2.3.3	Configuring the Access Computer to Run on a Microsoft Network	12
2.3.4	Login Recommendation	12
2.3.5	Changing Video Resolution to Match System	12
2.4	Touch Screen.....	13
2.5	Dynapro SC3 Driver Installation	13
2.5.1	Calibrating Dynapro SC3 Drivers	13
2.6	Shutting Down the Computer.....	14
3	HARDWARE CONFIGURATION	15
3.1	Communication Ports.....	15
3.1.1	Serial Port Connector	16
3.1.2	Printer Port	17
3.1.3	PS/2 Keyboard.....	17
3.1.4	PS/2 Mouse	18
3.1.5	Ethernet Port (E-NET)	19
3.1.6	USB Ports.....	19
3.2	Floppy Interface	20
3.3	ISA and PCI Expansion	21
4	SOFTWARE CONFIGURATION	23
4.1	Phoenix BIOS Setup Guide.....	23
4.1.1	The Menu Bar: Navigating the Setup Menus.....	23
4.1.2	The Legend Bar.....	23
4.1.3	The Field Help Window	24
4.1.4	The General Help Window	24
4.2	The Main Menu	25
4.2.1	Boot Sequence	26

4.2.2	Advanced Hard Disk Features.....	26
4.2.3	Memory Cache.....	28
4.2.4	Memory Shadow.....	30
4.2.5	Boot Options.....	31
4.2.6	Keyboard Features.....	32
4.3	The Advanced Menu.....	33
4.3.1	Integrated Peripherals.....	34
4.3.2	Advanced Chipset Control.....	37
4.3.3	PCI Devices.....	39
4.4	The Power Savings Menu.....	40
4.5	The Boot Menu.....	42
4.6	The Exit Menu.....	43
4.6.1	Discarding Changes & Exit.....	43
4.6.2	Save Changes & Exit.....	43
4.6.3	Get Default Values.....	44
4.6.4	Load Previous Values.....	44
4.6.5	Save Changes.....	44
5	TROUBLESHOOTING GUIDE.....	45
5.1	Major System Failures.....	45
5.1.1	No Response on Power-up.....	45
5.1.2	No Display with Backlight lit.....	45
5.1.3	No System Boot.....	45
5.2	Flat Panel Display.....	46
5.2.1	Unacceptable Display Image.....	46
5.2.2	Missing Pixels.....	46
5.2.3	Pixels stuck on.....	46
5.3	Display Backlight.....	47
5.3.1	Dim or No Backlight.....	47
5.4	Touch Panel.....	47
5.4.1	No response from Touch Panel.....	47
5.4.2	Improper placement of Cursor upon Touch.....	47
5.5	Accessories.....	47
5.5.1	PS/2 Mouse Inactive.....	47
5.5.2	PS/2 Keyboard Inactive.....	48
5.5.3	Printer Inactive.....	48
5.5.4	Printing Garbled Information.....	48
6	REPAIR PROCEDURES.....	49
6.1	Opening the Enclosure.....	49
6.2	Power Distribution.....	49
6.2.1	Substitute Power Cable.....	49
6.3	Adding Features.....	50
6.3.1	Installing Expansion Cards.....	50
6.3.2	PC/104 Card Installation.....	50
6.3.3	PCI/ISA Card Installation.....	51
6.3.4	Configuring Legacy ISA Cards.....	51
6.3.5	Memory Expansion.....	52
6.4	Calibration Procedures.....	52
6.4.1	Touchscreen Calibration.....	52
6.5	Maintenance Procedures.....	53
6.5.1	Changing the Air Filter Element.....	53
6.5.2	Filter Pads.....	53
6.5.3	Changing the Fuse.....	53

A. MECHANICAL OUTLINES 54
B. TECHNICAL DATA..... 56
C. WARRANTY STATEMENT..... 57

TABLE OF FIGURES

Figure 1-1 Access Mounting Bezel.....	2
Figure 1-2 Access Computer Packaging.....	4
Figure 1-3 Access Expanded CPU Packaging.....	5
Figure 2-1 Mounting Clip Locations	7
Figure 2-2 CPU to Bezel Mounting	7
Figure 2-3 Communication Connectors	8
Figure 2-4 Power Connections	9
Figure 3-1 Connector Locations	15
Figure 3-2 Shield Termination	16
Figure 3-3 PS/2 Keyboard Connector	17
Figure 3-4 PS/2 Mouse Connector	18
Figure 3-5 Floppy Drive Cable	20
Figure 6-1 CPU to Display Mounting.....	49
Figure 6-2 Power Connections	50

TABLES

Table 1 RS-232 Connections	16
Table 2 Printer Connections.....	17
Table 3 Keyboard Connections	17
Table 4 Mouse Connections	18
Table 5 Ethernet Connections.....	19
Table 6 USB Connections	19
Table 7 XT ISA Bus Connections.....	21
Table 8 AT ISA Bus Connections	21
Table 9 PCI Bus Connections	22

1 INTRODUCTION

The DisplayPac Access™ industrial flat-panel computer is a high performance workstation designed primarily for use as a hardware platform for PC-Based Control and Human Machine Interface (HMI) software packages. Easy to install, use, upgrade and maintain, this high quality, high reliability product is built to perform.

Built for harsh environments, a DisplayPac Access™ model is a self-contained PC compatible computer, with a built-in flat screen display housed in an industrial IP65 front panel. A rugged metal case protects the system against dust and other damage. The case also provides electromagnetic shielding to EN 55022: 1987 Class A (for emission) and EN 50082-1: 1992 (for immunity). State-of-the-art panel mounting and connecting systems makes it perfect for the shop floor or control area.

A DisplayPac Access™ industrial computer contains on-board Ethernet (10/100 Mbps), dual RS-232 COM ports (1 used by touchscreen) and a Centronics compatible Parallel port let you connect without the need for additional hardware.

The DisplayPac Access™ Flat Panel Display offers superior resolution and wide-angle visibility. Durable and sensitive analog resistive touchscreens increase the adaptability of Access industrial computers to your needs.

1.1 Specifications

Processor	333 MHz AMD K6-2
Memory	32 MB, upgradable to 256 MB
Displays	TFT Active Matrix Color LCD
Expansion Slots	PC/104 connector, optionally 2 ISA and 2 shared PCI/ISA
Bios	Phoenix
L2 Cache	512K
Drives	2 ½" IDE Hard Drive 1.44 MB floppy, front accessible CD-ROM, front accessible
Ports	10/100 Base-T Ethernet (RJ-45) 2 RS-232 serial ports (1 used for touchscreen) 1 Parallel, DB-25 Centronix compatible 1 PS/2 Keyboard port 1 PS/2 Mouse port
Operating Systems	Windows™ 95/98 or NT
Ambient Temperature	0°C to +45°C, no more than 10°C change per hour
Operational Humidity	5% to 90% relative humidity, non-condensing
Storage Temperature	-20°C to +60°C
Power Requirements	110-240VAC, 50-60Hz, 100W @ 50°C

1.2 System Description

Access products are modular for fast installation and easy maintenance. The Access Touchscreen and Bezel module is installed in the panel cutout with clips. The Display and Computer module (or the Expanded Computer modules) are installed on the Access Bezel using toggle clamps.

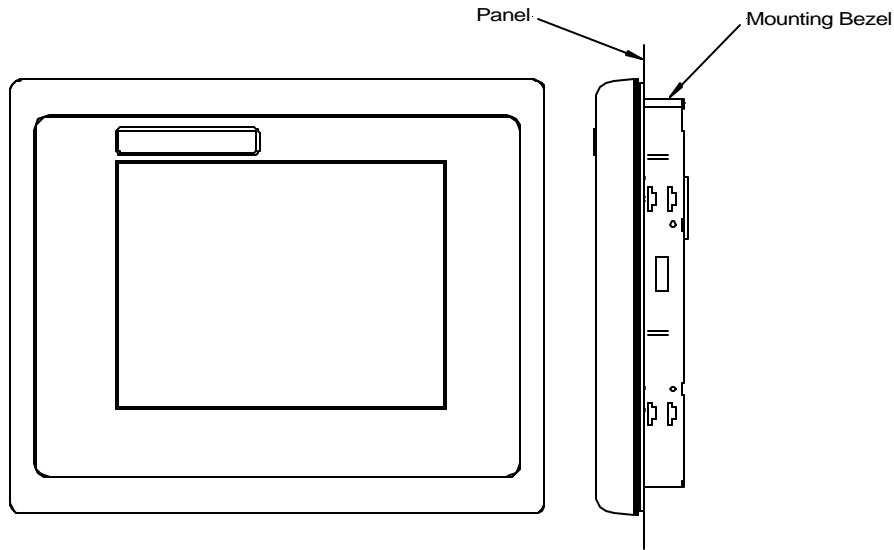

Figure 1-1 Access Mounting Bezel

1.2.1 Factory ready

Designed and built to withstand harsh, demanding environments, Access computers are the perfect tool for delivering information on the factory floor. If you're using CRTs and thinking about upgrading, consider the advantages that Access flat-panel computers can give you:

- Substantially smaller in size, they fit easier in any location
- Modular design allows for speedy installation
- Increased reliability reduces downtime in your factory
- Lower power consumption rate means reduced operating costs
- Immunity to electromagnetic emissions, resistance to vibration, and a wider operational temperature range enhance flexibility of placement

For superior performance and reliability, you can replace a CRT with an Access series flat-panel computer in virtually any application!

1.2.2 Modular simplicity

Access computers incorporate a unique modular design with features that make installation a snap and reduce your down-time dramatically. Unlike systems that require a specific PC bus video card, Access series flat-panel computers with state-of-the-art technology include your flat-panel display. For even greater convenience, you don't need a drill or screws to mount an Access computer in a panel—it simply clips in place.

1.2.3 Rugged Touchscreens

All Access computers come with a resistive touchscreen. Offering excellent durability and resolution, resistive technology can be used in a wide variety of applications and environments. All Access computers come with high performance device drivers that enable the touchscreen to emulate a mouse. They can operate any application designed to run under Windows 95/98™ and Windows NT™. Resistive touchscreens allow operation with gloved hands.

1.3 Access Computer Module, Standard

The Standard Computer module contains a powerful Processor and all the support functions required for a tough, industrial computer. A dedicated graphics controller card, attached to the motherboard, provides the interface for the flat panel display. Display panel resolution of VGA (640 x 480) with 256 color support on a color TFT screen is standard. The flat screen display provides High Luminance (equal to or greater than 200cd/m²), a Wide viewing angle and a built-in backlight with a long life backlight tube (equal to or greater than 25,000 hrs).

The module is easily attached or removed for maintenance. The standard Computer will allow installation of one PC/104 card for expansion in the enclosure.

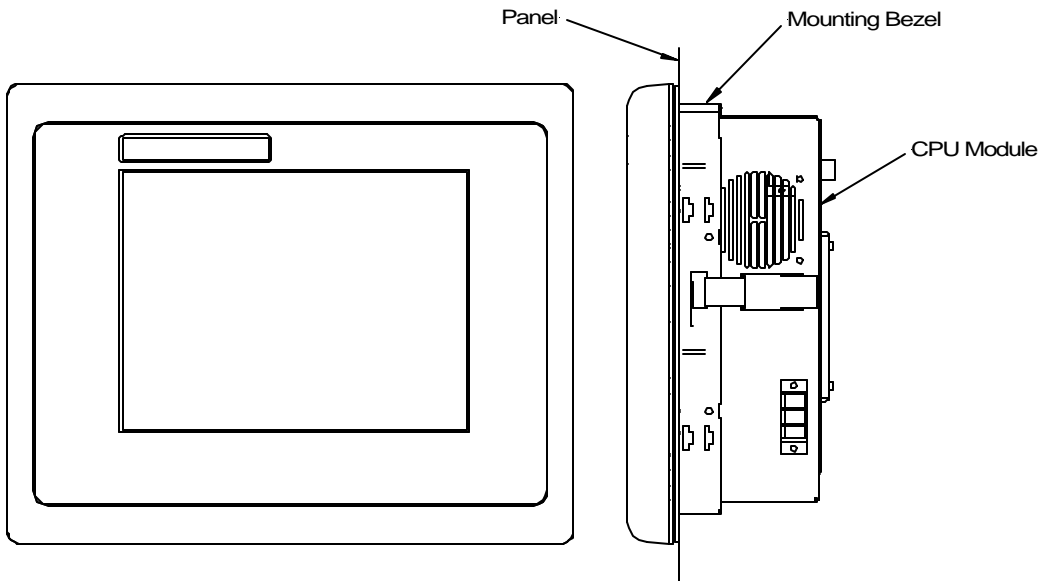

Figure 1-2 Access Computer Packaging

1.3.1 Features

Processor:	333 MHz, AMD K6-2.
Memory:	32 MB, upgradable to 256 MB.
Display:	10.4" VGA, 640 x 480 pixels, 256K color, TFT Active Matrix Color LCD
Touchscreen:	Analog Resistive touchscreen
Bios:	Phoenix.
L2 Cache:	512K.
Drives:	Standard 2.5" EIDE/ATA-2 interface Hard Drive.
Screen Drivers:	Windows™ 98 or NT.
Ports:	10/100 Base-T Ethernet (RJ-45). 2 RS-232 serial ports (1 used for touchscreen). 1 Parallel, DB-25 Centronix compatible. 1 PS/2 Mouse port. 1 PS/2 Keyboard port.
Operating Systems:	Windows™ 98 or NT.
Power Supply:	110-240VAC, 50-60Hz, 100W @ 50°C.

1.4 Access Computer Module, Expanded

The Expanded CPU module has the same features as the Standard CPU module with the addition of 1 PC/104 slot which allows up to two internal I/O modules. The PISA option board will provide 2 ISA expansion slots and 2 shared PCI/ISA expansion slots.

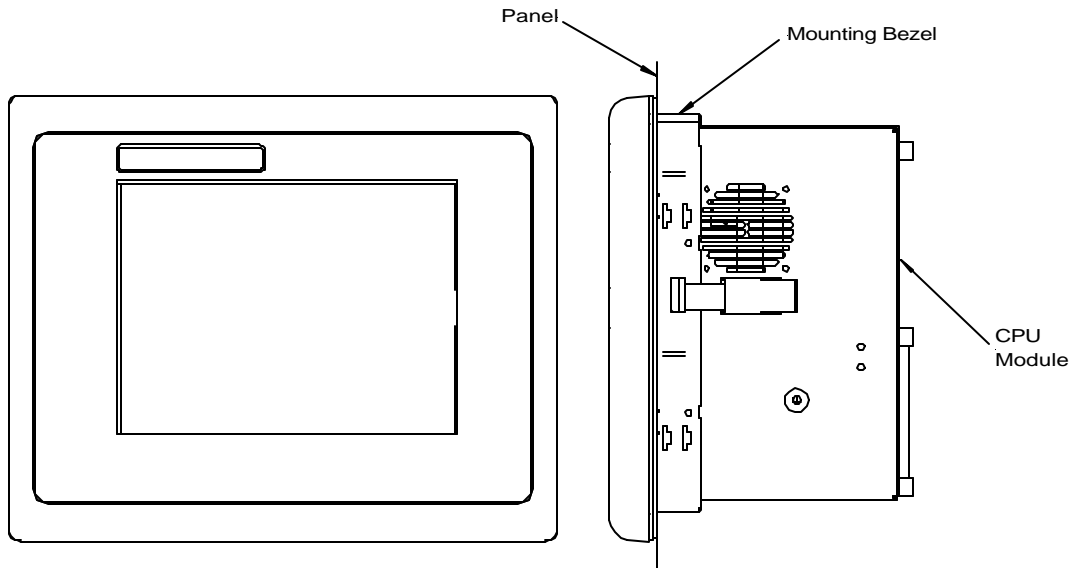

Figure 1-3 Access Expanded CPU Packaging

1.4.1 Additional Features

Expansion Slots:

PC/104 connector, optionally 2 ISA and 2 shared PCI/ISA

2 COMMISSIONING PROCEDURES

An Access computer consists of two components: an Access mounting bezel, and an Access CPU module. The Access product incorporates a unique modular design with features to make installation a snap. You don't need a drill to mount the Access bezel in a panel; it just clips in place. The Access CPU Module is connected to the display package using built-in toggle clamps.

2.1 Mounting Guidelines

NOTE: The IP65 standard applies to the front panel of the Access Bezel only, not the rear of the unit.

- In an industrial environment, the panel into which the unit is mounted should provide protection from dust, dirt and water.
- The panel into which the unit is mounted should be capable of supporting the weight of the Computer without distortion to the panel. The mounting clips will support a panel thickness of up to 10mm (0.39 inch).
- All eight mounting clips must be fitted properly to achieve a good seal between the Bezel and the panel to which it is mounted.
- Inlets and outlets must have at least 25mm of space around them and not be obstructed.
- Adequate airflow around the exterior of the unit is important to the interior temperature of the unit. Two fans are used to create air flow through the Access Computer, ensuring that a correct working temperature is maintained. Incoming air passes through a filter that removes dust and dirt. The filter should be checked and replaced regularly.

The installation process is simple. Make a cutout in the panel, clip the bezel in place, then attach the Access CPU module to the bezel.

2.2 Installing Access Bezel

Use the following procedure to mount the Access Bezel:

1. Copy the panel cutout dimensions to your panel and mark the panel cutout hole. Cut an opening in the panel to the dimensions shown. The cut-out allows a 1.2mm clearance on each edge of the front of the Bezel. Ensure the depth of the unit is accounted for when mounted.
2. Detach the rear housing from the front of the bezel by pushing the silver clamps, located in the middle of both sides of the rear housing, towards the front of the Bezel.
3. Unlatch the now loosened retaining clamps from the front housing.
4. Pull the rear housing apart from the front housing by pulling straight back on the rear housing.
5. Position the front of the Access bezel in the cut-out and fit the eight spring loaded retaining clips into the slots on the enclosure sides. All eight clips must be used to produce a good seal.

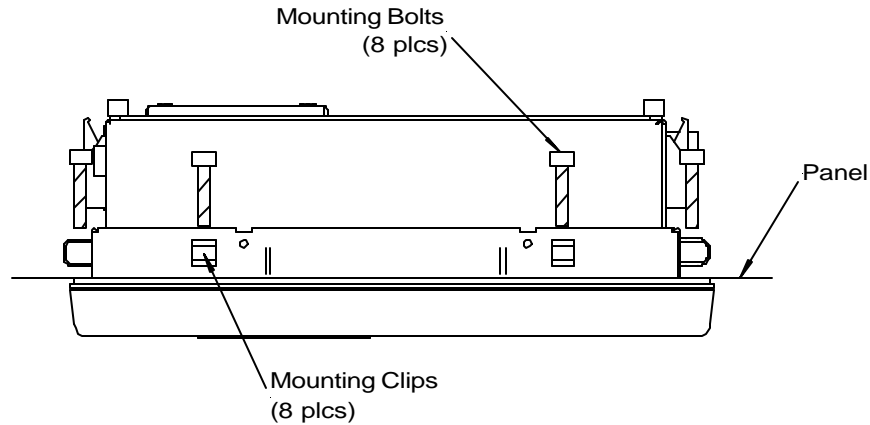

Figure 2-1 Mounting Clip Locations

6. Tighten the screws on each clip so that the nut compresses the spring. To ensure a good seal between the Display Station and the mounting panel, the clips must be tightened evenly. (Tighten each of the clips in turn, a little at a time.)
7. When the springs are fully compressed, no further tightening of the clips is necessary. The Access bezel is locked into place.

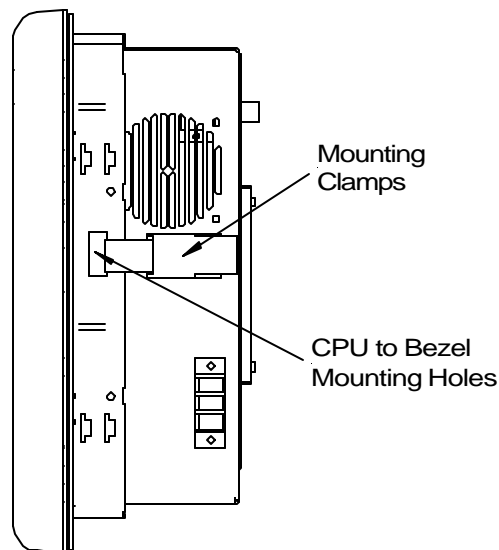

Figure 2-2 CPU to Bezel Mounting

8. Reattach the rear of the Access CPU module to the mounted front by lining up the rear housing with the front housing. Take special care to ensure that there is no dust inside the front housing. Any foreign material caught between the front and rear housing will become magnified during operation.
9. Insert the rear housing into the front housing, making sure that the touch screen nodes are lined up correctly.

CAUTION: Failure to line up the rear housing with the front of the Display Station may cause touch screen damage during reattachment.

10. Fasten the retaining clamps of the rear CPU housing to the corresponding slots in the front Bezel.
11. Pull the clamps back towards the rear of the unit, securing the rear housing to the front Bezel.

2.2.1 Completing the Access Installation Process

1. Connect Communication Cables to the Access CPU Module I/O Ports. Most are optional, depending on your application. Those that are required are listed in the following paragraphs.

The following drawing shows the connector panel on the Access CPU Module and which connections are to be attached to each.

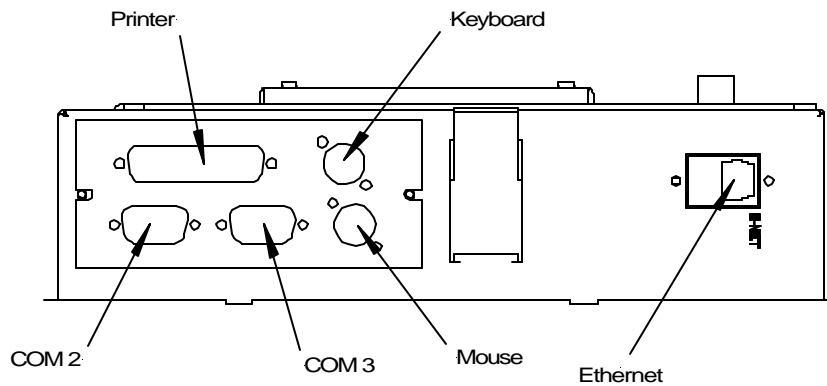

Figure 2-3 Communication Connectors

2. The touchscreen is connected to the internal serial port, COM 1 of your Access CPU Module and is not brought out to the connector panel. Make sure the touchscreen driver is loaded on your computer using the Touchscreen driver disk, which is provided. Refer to the touchscreen manual included with the Access CPU Module.
3. An external keyboard must be connected to the PS/2 keyboard port on the side of the Access CPU Module.
4. Connect up Power. Power connections are made to a terminal strip located on the side of the unit. To access the terminal strip, remove the rear cover. The power supply is an internal, autoranging AC power supply unit that accepts 110 - 240VAC, 50 - 60Hz and draws 100W@50°C. Note the terminal markings for Line (L), Ground (G), and Neutral (N).

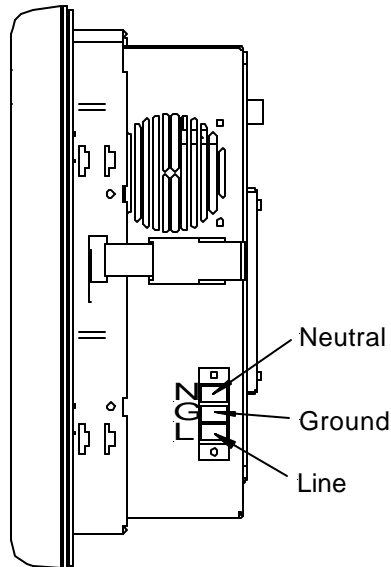

Figure 2-4 Power Connections

WARNING: System Grounding

THIS SYSTEM MUST BE CONNECTED TO A VERIFIED GOOD GROUND BEFORE BEING POWERED UP FOR THE FIRST TIME. EXTREME CARE SHOULD BE EXERCISED WHEN TESTING ANY LINE POWER VOLTAGES.

5. Make sure all optional connectors to be used in this installation are in place.

2.2.2 Powering Up the Access Computer

CAUTION: *Do not connect or disconnect external devices, such as a printer or a PS/2 mouse or keyboard, while the unit is powered. Failure to observe this precaution could result in damage to the equipment.*

The computer automatically performs self-test diagnostics each time it is powered up. The self-test consists of a series of checks that verify correct performance of the computer hardware. When the self-test is being performed, you will see the message XXXX KB OK displayed on the screen, where XXXX is a number that increases until it matches the amount of usable memory.

2.2.3 System Test and Initialization

These routines test and initialize board hardware. If the routines encounter an error during the tests, you will see an error message on the screen. There are two kinds of errors: fatal and non-fatal. If a non-fatal error occurs, the system can usually continue the boot up sequence. Non-fatal error messages usually appear on the screen with the following instruction:

press <F1> to RESUME

Write down the message and press the F1 key to continue the start-up sequence.

2.2.4 System Configuration Verification

These routines check the current system configuration against the values stored in the CMOS memory. If they don't match, the program will generate an error message. To correct this condition, you will need to run the BIOS setup program and correct the configuration information in memory.

There are three situations that might warrant changing the CMOS settings:

1. You are starting your system for the first time.
2. You have changed the hardware attached to your system.
3. The CMOS memory had lost power and the configuration information has been erased.

2.3 BIOS Settings

It is normally unnecessary to change the hardware configuration settings in the CMOS memory. If these settings become corrupt, use the following procedures to reload the factory configuration:

1. Connect a keyboard to the unit and turn on the power.
 2. During the computer power-up sequence, press the F2 key, when prompted, to enter Setup mode. A screen will appear offering several options for changing settings, restoring default settings, and other functions.
 3. Select the Load Setup Defaults option. Then, select the Save CMOS settings option. You will be prompted to exit. *Do not* exit at this time.
 4. Go into Standard CMOS Setup and make the following selections:
 - Primary HDD master AUTO AUTO
 - Primary HDD slave AUTO AUTO
 - Secondary HDD master AUTO AUTO
 - Secondary HDD slave AUTO AUTO
 - Drive A NONE
 - Drive B NONE
 5. Exit Standard CMOS Setup.
 6. Go into Integrated Peripherals Setup. Set parallel port to ECP+EPP.
 7. Select Save and then Exit Setup. The startup sequence should begin.
- The system is now configured with factory CMOS settings.

2.3.1 Setting Up Windows 98 Systems

1. A PS/2 mouse is recommended to help navigate through the setup screens. Power system down, connect the mouse, then restart the system.
2. The Windows 98 Setup screen will appear.
3. Type your name.
4. Press the Tab key and type your company name
5. Press Enter.
6. Read the license agreement

7. Click your choice.
8. Click Next.
9. Enter the Windows 98 Certificate of Authenticity number found on the front of your Windows 98 manual. Press Enter.
10. The network card used in these systems supports Plug & Play installation.
11. Windows 98 will go through setup.
12. When prompted for Date/Time Properties, use your left and right arrow keys to set the time zone to your time zone. Press Enter.
13. If you have a printer connected, click Next and select your printer model type. If not, click the Cancel button. The Welcome to Windows 98 window will appear.
14. Click Close for the Welcome to Windows 98 window.

2.3.2 Setting Up Windows NT Systems

A PS/2 mouse is recommended to help navigate through the setup screens. Power system down, connect the mouse and restart the system.

1. Power on the unit.
2. Read license agreement
3. Tab to your choice and press Enter.
4. Press Enter to start the Windows NT Setup.
5. Type your name
6. Press the Tab key and type your company name.
7. Press Enter.
8. Enter your Windows NT Authentication number found on your Windows NT manual. You will need to use the Tab key to get to each number field. If correct, press Enter.
9. Enter a Computer name. This name should be unique to other computers on the same network. Press Enter.

Note: Your system has been set up to enable autologon. Autologon allows the system to boot into Windows NT without your having to use a keyboard to press Ctl-Alt-Del.

10. You will be prompted for a password.

To use the autologon feature, type admin for the password. Press the Tab key and type admin in the Confirm Password box. Press Enter.

To skip the password, press Enter

To assign a password, type in a password, press the Tab key, and type the password in the Confirm Password box. Press Enter.

11. Press Enter to continue with Windows NT Setup.
12. Click "Finish."

2.3.3 Configuring the Access Computer to Run on a Microsoft Network

Before setting up your new Access Computer for the network, you should consult with your network administrator. Duplicate TCP/IP addresses and duplicate computer names on the same network can cause network problems.

1. Click the Start icon, then click Settings and Control Panel.
2. In the Control Panel window, double click the Network icon. The Network dialog box will appear.
3. In the Network dialog box, click the Identification tab. You will need to type in your Computer name, Workgroup name, and Computer Description.
4. To allow sharing,
 - A. Go to the Configuration tab and click the File and Print Sharing button. The File and Print Sharing dialog box will appear.
 - B. Check the File and Print Sharing options that you want and click OK.
5. To add the TCP/IP protocol,
 - A. Go to the Configuration tab and click the Add button. The Select Network Component dialog box will appear.
 - B. Click the Protocol icon and click Add. The Select Network Protocol dialog box will appear.
 - C. In the Manufacturer list, select Microsoft. In the Protocol list, select TCP/IP. Click OK.
 - D. Change the Address from 10.0.0.1 to a unique address. Change the default subnet mask 255.0.0.0 to your subnet mask.
 - E. Click OK twice.
6. When you have finished setting up the Network, click OK in the Network dialog box. Click Yes to reboot your system now.

2.3.4 Login Recommendation

If you type admin as your Administrator password, you will automatically log on as Administrator.

2.3.5 Changing Video Resolution to Match System

When the Access computer is shipped it is configured for 640 x 480 resolution to allow it to operate with the standard Access Display. When using the 640 x 480 mode on a display with higher resolution capability the image will not occupy the full screen. To resolve this issue you will need to set the screen resolution using the following instructions:

1. From the Windows Task Bar select the "Settings" icon
2. Select the "Control Panel"
3. Select "Display"
4. Select the "Settings" Tab
5. In the box labeled "Desktop area" select the 640 x 480 resolution for your Access Display.
6. Click the test button to verify that the changes you have selected are working properly.
7. After the 5 second test mode has completed successfully, click "OK", followed by the "Apply" button. Your display should now be set up properly.

2.4 Touch Screen

The Access computer includes a resistive overlay touch screen on the flat panel display. The touch screen has a touch-resolution of 1024 x 1024 touch points and provides an efficient and reliable method of entering information. The screen responds to the touch of your finger, with or without a glove.

The touch screen is connected internally to the COM 1 serial port, which allows it to function with Automation software. If you install a card that has settings that conflict with the COM 1 serial port, you will need to change the card's configuration.

2.5 Dynapro SC3 Driver Installation

1. Insert Dynapro SC3 Driver disk into your computers floppy drive.
2. Run A:\INSTALL.EXE
3. Driver and Path verification screen. These settings are not modifiable. They are for verifying the driver and version that is being installed. Click Next.
Configuration Screen.
4. Install Parameter Summary Screen. Verify settings are correct. Click Install.
5. After installation is complete, restart Windows for the changes to take affect by clicking "Yes" when prompted.
6. Remove floppy disk while system is rebooting.
7. Cursor may not respond correctly to touches after system has finished booting for the first time.
8. Run Driver Configuration as described in the following section.

2.5.1 Calibrating Dynapro SC3 Drivers

The cursor may not respond to the touchscreen correctly after system has finished booting for the first time.

1. Run Start – Programs – Touch Screen Utilities – Configuration
2. Click "Interface..."
3. Click "Advanced..."
4. Change "Screen Wires:" from 4 to 8 using the pulldown menu.
5. Click "OK" to exit Advanced Controller Option.
6. Click "OK" to exit Interface Configuration Options.
7. Choose "Calibration..." on Configuration Utilities Screen.
8. Choose "Calibrate"
9. Touch the 3 targets as they appear on the screen.
10. The first in the upper left corner, the second in the lower right, and the third in the middle right.
11. Click "OK" to exit calibration screen.
12. Click "Exit" to close Configuration Utility.

2.6 Shutting Down the Computer

CAUTION: To avoid damaging files, always shut down Windows software before removing power from your Computer.

To shut down Windows software, select **Shut Down** from the Start menu.

3 HARDWARE CONFIGURATION

3.1 Communication Ports

A side access panel houses all serial and input device ports (Ethernet, PS/2 keyboard, and PS/2 mouse). The DisplayPAC Access provides the following I/O interface channels:

- two serial interface ports using standard 9-pin D type connectors
- one parallel port (can be used for CD-ROM drive)

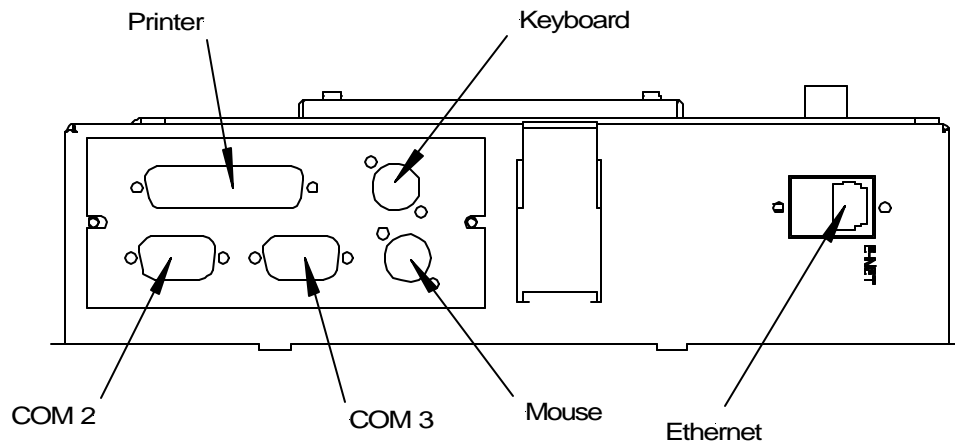

Figure 3-1 Connector Locations

Access Extended CPU Models also provide the following data ports:

- Two USB ports
- Floppy Drive port

CAUTION: To ensure that the installation meets the EMC radiation specification, the communication cables must comply with the following requirements:

- The cables must be shielded
- The D type connector covers must provide EMC shielding (e.g. Metallized plastic or die cast metal covers)
- The cables must be terminated with 360 degree termination of the shield, as illustrated below:

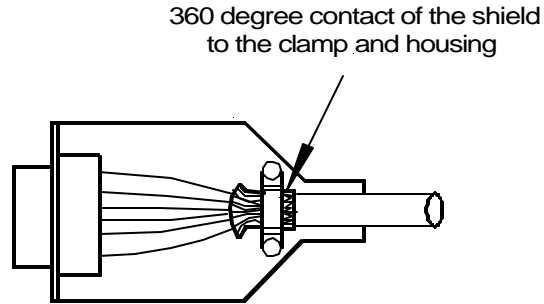

Figure 3-2 Shield Termination

3.1.1 Serial Port Connector

The DisplayPac Access standard CPU and EXP CPU products have two RS-232 serial ports available on the side of the computer module. An additional serial port is used for the touchscreen and is not available for the user. The pinout of the connector is shown in the table below:

Pin	Signal
1	DCD
2	RX DATA
3	TX DATA
4	DTR
5	GND
6	DSR
7	RTS
8	CTS
9	RI

Table 1 RS-232 Connections

3.1.2 Printer Port

The printer port on the Access Computer has a Multi-mode high performance parallel port. In standard mode it provides bi-directional SPP, in enhanced mode it is EPP V1.7 and EPP V1.9 compatible, and in high-speed mode is ECP, IEEE1284 compliant.

The pinout shown in the table below:

Signal	Pin	Pin	Signal
/STB	1	14	/AFD
Data 0	2	15	/ERR
Data 1	3	16	/INIT
Data 2	4	17	/SLIN
Data 3	5	18	Gnd
Data 4	6	19	Gnd
Data 5	7	20	Gnd
Data 6	8	21	Gnd
Data 7	9	22	Gnd
/ACK	10	23	Gnd
Busy	11	24	Gnd
PE	12	25	Gnd
SLCT	13		

Table 2 Printer Connections

3.1.3 PS/2 Keyboard

The Keyboard DIN connector on the side of the Access CPU is compatible with PS/2 keyboards.

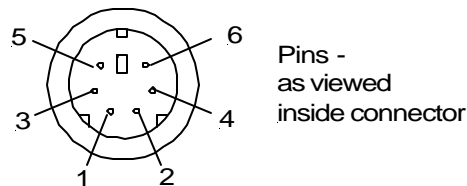

Figure 3-3 PS/2 Keyboard Connector

Pin	Signal
1	Keyboard Data
2	N/C
3	Ground
4	+5Vdc
5	Keyboard Clock
6	N/C

Table 3 Keyboard Connections

3.1.4 PS/2 Mouse

The touch screen and PS2 mouse will work simultaneously if the mouse is Microsoft or IBM PS/2 compatible. Because Microsoft Windows can load only one mouse driver at a time, it is not possible to provide simultaneous support for a mouse that requires its own specific Windows driver.

If you are installing an optional serial card, none of the ports can be configured as COM 1, which conflicts with the touch screen.

A PS/2 mouse can be connected to the Access product as shown in the following figure.

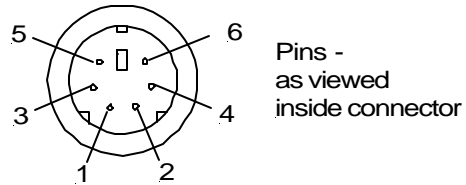

Figure 3-4 PS/2 Mouse Connector

Pin	Function
1	Mouse Data
2	N/C
3	Ground
4	+5Vdc
5	Mouse Clock
6	N/C

Table 4 Mouse Connections

3.1.5 Ethernet Port (E-NET)

The DisplayPac Access CPU Modules provide an industry standard RJ-45 connector, for 10 Mb/s and 100 Mb/s operation. It supports N-way auto-negotiation, full duplex flow control in compliance with IEEE 802.3x.

Unshielded twisted pair (UTP) cables connect the DisplayPac Access to other computers, hubs and bulkhead connectors. DisplayPac Access supports most popular Ethernet networks.

The Ethernet Controller used is a "Plug and Play" device and resources can be set by program control. The exact resource utilization varies with system configuration. The Ethernet controller will "seek" available resources. In addition, the Ethernet Controller can be disabled through user settings in the BIOS Setup and in the Windows95™ Control Panel | System | Device Manager.

The table below has the RJ-45 connector pinout:

Pin	Signal
1	Transmit +
2	Transmit -
3	Receive +
4	N/C
5	N/C
6	Receive -
7	N/C
8	N/C

Table 5 Ethernet Connections

3.1.6 USB Ports

The Access Extended CPU provides an interface for two USB ports. Below is a table containing the pinouts of the USB ports.

Function	Pin	Pin	Function
+5V fused	1	2	+5V fused
Port 1-	3	4	Port 2-
Port 1+	5	6	Port 2+
Ground	7	8	Ground
Shield	9	10	Shield

Table 6 USB Connections

3.2 Floppy Interface

The Access Extended CPU includes a 2.88MB floppy disk controller which supports two 360K/ 720K/ 1.2M/ 1.44M/2.88M floppy disk drives. A and B drives can be swapped.

It provides support for 3-Mode, enhanced digital data separation and software write protection. The board connector is a 17 x 2 straight locking 0.1" center header.

The drive cable for the SBC-PII is identical to that used in an IBM-PC. Wires 10 through 16 are swapped. This swap, or flip, provides the drive select to the drives. Attach drive A on the connector at the end of the cable. Drive B uses the middle connector on the cable. Set the straps or configuration switch on the drives so that both drives are configured as the second drive in the system. Note that 3.5" floppy drives require header-type connectors while 5.25" drives require card-edge connectors.

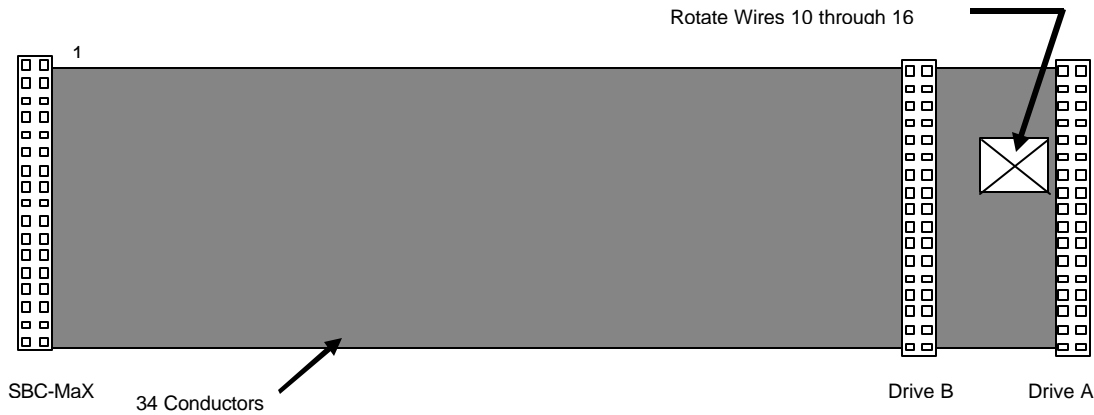

Figure 3-5 Floppy Drive Cable

The BIOS for the SBC-PII must be informed of the types of floppy drives attached to the system. This is accomplished using the BIOS Setup. See Section 4.1.

3.3 ISA and PCI Expansion

The DisplayPac Access Expanded CPU Modules have a backplane available for installing PCI and ISA expansion cards. The backplane has two slots dedicated to ISA expansion cards and also has two slots, which can be used for either ISA or PCI cards.

NOTE: There are actually three PCI slots on the DisplayPac Access CPU backplane. Only two PCI slots can be used unless the on-board Ethernet controller is disabled.

NOTE: The ISA and PCI cards installed in the Access Expanded chassis can have a maximum card length of 9".

Signal	Pin	Pin	Signal
I/O Channel Check	A1	B1	Ground
SDATA 07	A2	B2	Reset
SDATA 06	A3	B3	+5 Volts
SDATA 05	A4	B4	IRQ 2/9
SDATA 04	A5	B5	-5 Volts
SDATA 03	A6	B6	DRQ2
SDATA 02	A7	B7	-12 Volts
SDATA 01	A8	B8	/ZEROWS
SDATA 00	A9	B9	+12V
I/O Channel Ready	A10	B10	Ground
AEN	A11	B11	/SMEMW
SADDRESS 19	A12	B12	/SMEMR
SADDRESS 18	A13	B13	/IOW
SADDRESS 17	A14	B14	/IOR
SADDRESS 16	A15	B15	/DACK 3
SADDRESS 15	A16	B16	DRQ 3

Signal	Pin	Pin	Signal
SADDRESS 14	A17	B17	/DACK 1
SADDRESS 13	A18	B18	DRQ 1
SADDRESS 12	A19	B19	/REFRESH
SADDRESS 11	A20	B20	CLOCK
SADDRESS 10	A21	B21	IRQ 7
SADDRESS 09	A22	B22	IRQ 6
SADDRESS 08	A23	B23	IRQ 5
SADDRESS 07	A24	B24	IRQ 4
SADDRESS 06	A25	B25	IRQ 3
SADDRESS 05	A26	B26	/DACK 2
SADDRESS 04	A27	B27	T/C
SADDRESS 03	A28	B28	ALE
SADDRESS 02	A29	B29	+5 Volts
SADDRESS 01	A30	B30	14.3818 MHz
SADDRESS 00	A31	B31	Ground

Table 7 XT ISA Bus Connections

Signal	Pin	Pin	Signal
Ground			Ground
/SBHE	C1	D1	/MEM CS 16
LA 23	C2	D2	/IO CS 16
LA 22	C3	D3	IRQ 10
LA 21	C4	D4	IRQ 11
LA 20	C5	D5	IRQ 12
LA 19	C6	D6	IRQ 15
LA 18	C7	D7	IRQ 14
LA 17	C8	D8	/DACK 0
/MEMR	C9	D9	DRQ 0

Signal	Pin	Pin	Signal
/MEMW	C10	D10	/DACK 5
SDATA 08	C11	D11	DRQ 5
SDATA 09	C12	D12	/DACK 6
SDATA 10	C13	D13	DRQ 6
SDATA 11	C14	D14	/DACK 7
SDATA 12	C15	D15	DRQ 7
SDATA 13	C16	D16	+5 Volts
SDATA 14	C17	D17	/MASTER
SDATA 15	C18	D18	Ground

Table 8 AT ISA Bus Connections

Signal	Pin	Pin	Signal
/TRST	A1	B1	-12 Volts
+12 Volts	A2	B2	TCK
TMS	A3	B3	Ground
TDI	A4	B4	No Connection
+5 Volts	A5	B5	+5 Volts
/IRQA	A6	B6	+5 Volts
/IRQC	A7	B7	/IRQB
+5 Volts	A8	B8	/IRQD
No Connection	A9	B9	/PRSNT11
+5 Volts	A10	B10	No Connection
No Connection	A11	B11	/PRSNT12
Ground	A12	B12	Ground
Ground	A13	B13	Ground
No Connection	A14	B14	No Connection
/RESET	A15	B15	Ground
+5 Volts	A16	B16	CLK
/GNT	A17	B17	Ground
Ground	A18	B18	/REQ
/PME	A19	B19	+5 Volts
ADDR/DATA 30	A20	B20	ADDRESS 31
+3.3 Volts	A21	B21	ADDRESS 29
ADDR/DATA 28	A22	B22	Ground
ADDR/DATA 26	A23	B23	ADDRESS 27
Ground	A24	B24	ADDRESS 25
ADDR/DATA 24	A25	B25	+3.3 Volts
IDSEL	A26	B26	/CBE3
+3.3 Volts	A27	B27	ADDRESS 23
ADDR/DATA 22	A28	B28	Ground
ADDR/DATA 20	A29	B29	ADDRESS 21
Ground	A30	B30	ADDRESS 19
ADDR/DATA 18	A31	B31	+3.3 Volts

Signal	Pin	Pin	Signal
ADDR/DATA 16	A32	B32	ADDR/DATA 17
+3.3 Volts	A33	B33	/CBE2
/FRAME	A34	B34	Ground
Ground	A35	B35	/IRDY
/TRDY	A36	B36	+3.3 Volts
Ground	A37	B37	/DEVSEL
/STOP	A38	B38	Ground
+3.3 Volts	A39	B39	/LOCK
SDONE	A40	B40	/PERR
/SBO	A41	B41	+3.3 Volts
Ground	A42	B42	/SERR
PAR	A43	B43	+3.3 Volts
ADDR/DATA 15	A44	B44	/CBE1
+3.3 Volts	A45	B45	ADDR/DATA 14
ADDR/DATA 13	A46	B46	Ground
ADDR/DATA 11	A47	B47	ADDR/DATA 12
Ground	A48	B48	ADDR/DATA 10
ADDR/DATA 09	A49	B49	Ground
Key	A50	B50	Key
Key	A51	B51	Key
/CBE0	A52	B52	ADDR/DATA 08
+3.3 Volts	A53	B53	ADDR/DATA 07
ADDR/DATA 06	A54	B54	+3.3 Volts
ADDR/DATA 04	A55	B55	ADDR/DATA 05
Ground	A56	B56	ADDR/DATA 03
ADDR/DATA 02	A57	B57	Ground
ADDR/DATA 00	A58	B58	ADDR/DATA 01
+5 Volts	A59	B59	+5 Volts
/ACK64	A60	B60	/REQ64
+5 Volts	A61	B61	+5 Volts
+5 Volts	A62	B62	+5 Volts

Table 9 PCI Bus Connections

4 SOFTWARE CONFIGURATION

4.1 Phoenix BIOS Setup Guide

The Access CPU modules are shipped with the BIOS already configured for proper operation. This chapter summarizes the complete BIOS functionality for customers who require a custom BIOS configuration.

Use the Phoenix BIOS Setup program for:

- Setting system time and date.
- Installing new drives for hard disks and floppy disks.
- Enhancing system performance by controlling advanced features such as shadow memory and cache memory.
- Configuring system resources.

4.1.1 The Menu Bar: Navigating the Setup Menus

The Menu Bar at the top of the window lists these selections:

Main	Use this menu for basic system configuration.
Advanced	Use this menu to set the Advanced Features of the system's chipset.
Power Savings	Use this menu to configure Power Management features.
Boot	Use this menu to select the boot device.
Exit	Exits the current menu.

Use the left/ right " ← → " arrow keys to make a selection.

4.1.2 The Legend Bar

Use the keys listed in the legend bar on the bottom to make your selections or exit the current menu. The following chart describes the legend keys and their alternates:

Key	Function
<F1> or <Alt- H>	General Help window.
<Esc>	Exit this menu.
← or → arrow keys	Select a different menu.
↑ or ↓ arrow keys	Move cursor up and down.
<Tab> or <Shift- Tab>	Cycle cursor through fields.
<Home> or <End>	Move cursor to top or bottom of window.
<PgUp> or <PgDn>	Move cursor to next or previous page.
<F5> or <->	Select the Previous Value for the field.
<F6> or <+> or <Space>	Select the Next Value for the field.
<F9>	Load the Default Configuration values for this menu.
<F10>	Load the Previous Configuration values for this menu.
<Enter>	Execute Command or Select Submenu.
<Alt- R>	Refresh screen.

To select an item, use the arrow keys to highlight the field you want. Then use the plus and minus value keys to select a value for that field. The Save Changes commands in the Exit Menu save the values currently displayed in all the menus. To display a sub menu, use the arrow keys to highlight the sub menu you want, then press <Enter>. A pointer (␣) marks all sub menus.

4.1.3 The Field Help Window

The help window on the right side of each menu displays the help text for the currently selected field. It updates as you move the cursor to each field.

4.1.4 The General Help Window

Pressing <F1> or <Alt H> on any menu brings up the General Help window that describes the legend keys and their alternates:

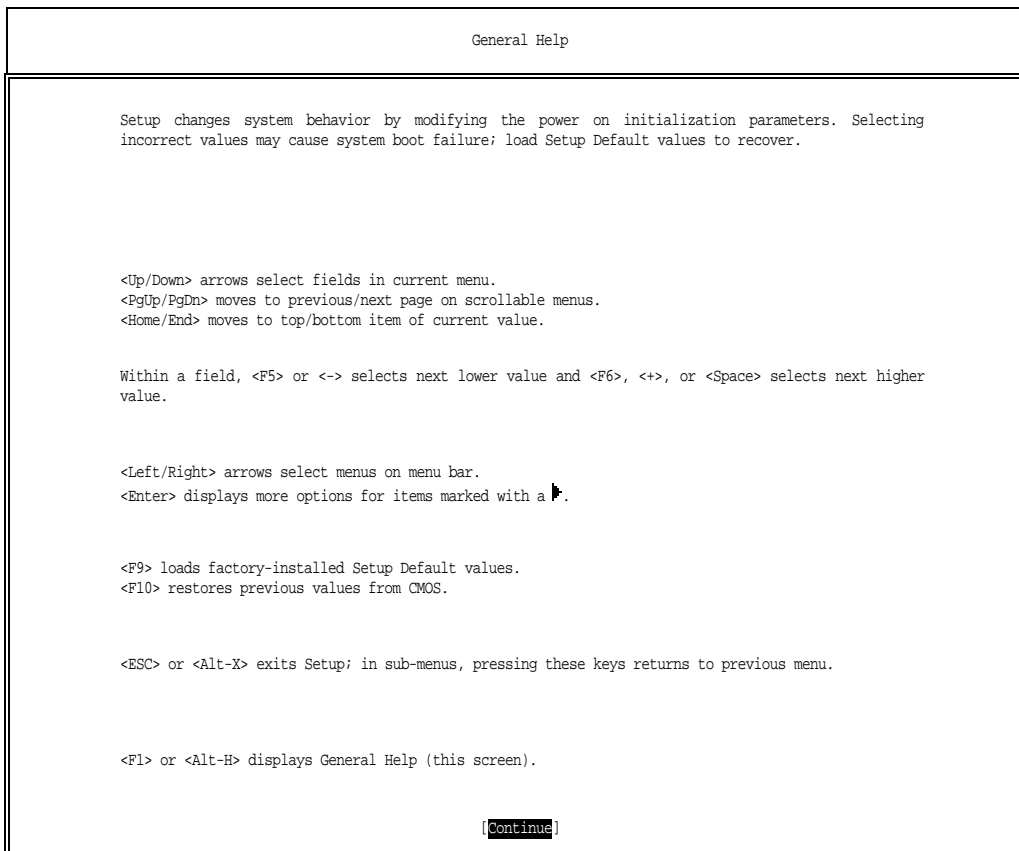

The scroll bar on the right of any window indicates that there is more than one page of information in the window.

Use <PgUp> and <PgDn> to display all the pages.

Pressing <Home> and <End> displays the first and last page.

Press <Esc> to exit the current window.

4.2 The Main Menu

To start the Phoenix BIOS Setup utility:

Turn on or reboot your system. Phoenix BIOS displays this message:

Press <F2> to enter SETUP

Pressing <F2> displays the Main Menu, which looks like this:

Phoenix BIOS NoteBIOS 4.0 Setup - Copyright 1985-96 Phoenix Technologies Ltd.					
Main	Advanced	Power	Savings	Boot	Exit
					Item Specific Help
System Time: [16:19:21] System Date: [03/01/1998] Diskette A: [1.44MB, 3½"] Diskette B: [Not Installed] ▶ Primary Master: (1350Mb) ▶ Primary Slave: (None) ▶ Secondary Master: (None) ▶ Secondary Slave: (None) Video System: [EGA/VGA] ▶ Memory Cache ▶ System Shadow ▶ Boot Options ▶ Numlock [Auto] System Memory: 640 KB Extended Memory: 31 MB					<Tab>, <Shift-Tab> or <Enter> selects field
F1 Help	↑↓ Select Item	+/- Change Values		F9 Setup Defaults	
ESC Exit	←→ Select Menu	Enter Select ▶ Sub-Menu		F10 Previous Values	

You can make the following selections on the Main Menu itself. Use the sub menus for other selections.

Feature	Options	Description
System Time	HH: MM: SS	Set the system time.
System Date	MM/ DD/ YYYY	Set the system date.
Diskette 1 Diskette 2	360 kB, 5 ¼" 1.2 MB, 5 ¼" 720 kB, 3 ½" 1.44MB, 3 ½" 2.88 MB, 3 ½" Not installed Disabled	Select the type of floppy disk drive installed in your system.
System Memory	N/ A	Displays amount of conventional memory detected during bootup.
Extended Memory	N/ A	Displays the amount of extended memory detected during bootup.

4.2.1 Boot Sequence

You can set the boot sequence of the bootable drives by opening the Boot Menu.

The Master and Slave settings on the Main Menu control these types of devices:

- Hard disk drives
- CD-ROM drives

Phoenix BIOS 4.04 supports up to two IDE disk adapters, called primary and secondary adapters. Each adapter supports one master drive and one optional slave drive in these possible combinations:

- 1 Master
- 1 Master, 1 Slave
- 2 Masters
- 2 Masters, 1 Slave
- 2 Masters, 2 Slaves

There is one IDE connector for each adapter, Primary IDE and Secondary IDE. There can be two connectors on each ribbon cable attached to each IDE connector. When you enter Setup, the Main Menu displays the results of Autotyping—information each drive provides about its own size and other characteristics—and how they are arranged as Masters or Slaves on your machine.

Note:

Do not attempt to change these settings unless you have an installed drive that does not autotype properly (such as an older hard disk drive that does not support autotyping).

If you need to change your drive settings, use the Master or Slave sub-menu as explained in the following.

4.2.2 Advanced Hard Disk Features

Selecting one of the Master or Slave sub menus on the Main Menu displays this menu:

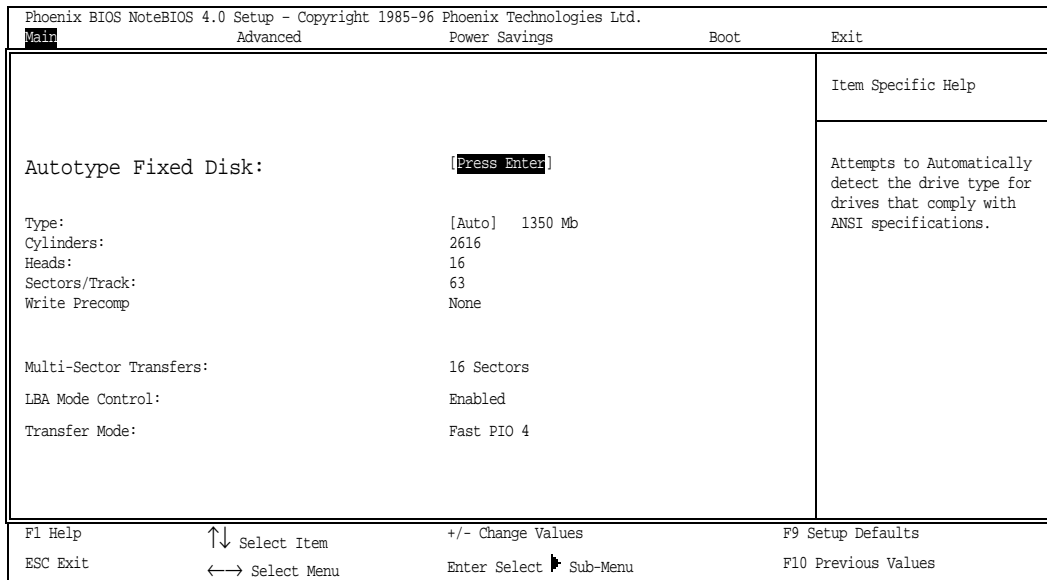

Use the following chart to configure the hard disk drive with Advanced Hard Disk Features:

Feature	Options	Description
Type	None 1 to 39 User Auto CD	None = Autotyping is not able to supply the drive type or end user has selected None, disabling any drive that may be installed. 1 to 39 = Fills in all remaining fields with values for predefined hard disk type. User = You supply the hard disk drive information in the following fields. Auto = Autotyping, the drive Autotypes on each boot. CD-ROM = CD-ROM drive.
Cylinders	1 to 65,536	Number of cylinders.
Heads	1 to 16	Number of read/ write heads.
Sectors/ Track	1 to 63	Number of sectors per track.
Multi- Sector Transfers	Disabled Standard 2 sectors 4 sectors 8 sectors 16 sectors	Any selection except Disabled determines the number of sectors transferred per block. Standard is 1 sector per block.
LBA Mode Control	Enabled Disabled	Enabling LBA causes Logical Block Addressing to be used in place of Cylinders, Heads, & Sectors.
32- Bit I/ O	Enabled Disabled	Enables 32- bit communication between CPU and IDE card.
Transfer Mode	Standard Fast PIO 1 Fast PIO 2 Fast PIO 3 Fast PIO 4	Selects the method for transferring the data between the hard disk and system memory.

CAUTION: Incorrect settings can cause your system to malfunction.

4.2.3 Memory Cache

Enabling cache enhances performance by holding data most recently accessed in regular memory (dynamic RAM or DRAM) in a special storage area of static RAM (SRAM), which is faster. Before accessing regular memory, the CPU first accesses the cache. If it does not find the data it is looking for there, it accesses system memory.

Selecting "Memory Cache" from the Main menu displays the menu shown here:

Phoenix BIOS NoteBIOS 4.0 Setup - Copyright 1985-96 Phoenix Technologies Ltd.			
Main	Advanced	Power Savings	Exit
Auto Cache Configuration: [Enabled] External cache: [Enabled] Cache System BIOS area: [Enabled] Cache Video BIOS area: [Disabled] Tag Compare Wait State: 0 Wait L2 Tag Option: [7 Bits] L2 WB Wait State: [X-4-4-4 (0Wait)] B.Rd & L.F. #NA [Enabled] L2 Back to Back control: [Disabled] Cache Memory Region CC00-CFFF: [Disabled] D000-D3FF: [Disabled] D400-D7FF: [Disabled] D800-DBFF: [Disabled] DC00-DFFF: [Disabled] E000-EFFF: [Enabled]			Item Specific Help Advanced cache features will automatically set to predefined values on every boot.
F1 Help	↑↓ Select Item	+/- Change Values	F9 Setup Defaults
ESC Exit	←→ Select Menu	Enter Select Sub-Menu	F10 Previous Values

Use the following chart to configure the memory cache.

Feature	Options	Description
Auto Cache Configuration	Enabled Disabled	Advanced cache features will automatically set to predefined values on every boot.
External Cache	Enabled Disabled	Enables or Disables L2 Cache.
Cache System BIOS area	Enabled Disabled	Controls caching of the system BIOS area.
Cache Video BIOS area	Enabled Disabled	Controls caching of the video BIOS area.
L2 Tag Option	7 Bits 8 Bits	Selects the number of L2 Cache Tag Bits.
L2 WB Wait State	X-4-4-4 (0Wait) X-5-5-5	Sets the L2 WB wait state timing.
B.Rd & L.F. #NA	Enabled Disabled	Sets Pipeline Sync-SRAM control with burst read and line fill #NA functions.
L2 Back to Back Control	Enabled Disabled	L2 Back to Back read X-1-1-1... control with I/O concurrent.
Cache Memory Regions:		
CC00- CFFF	Enabled Disabled	Enable/ Disables Caching of option ROM in this area.
D000-D3FF	Enabled Disabled	Cache shadowed option ROM in this area.
D400-D7FF	Enabled Disabled	Cache shadowed option ROM in this area.
D800-DBFF	Enabled Disabled	Cache shadowed option ROM in this area.
DC00-DFFF	Enabled Disabled	Cache shadowed option ROM in this area.
E000-EFFF	Enabled Disabled	Cache shadowed option ROM in this area.

CAUTION: Incorrect settings can cause your system to malfunction.

4.2.4 Memory Shadow

Selecting "Memory Shadow" from the Main Menu displays the menu shown here.

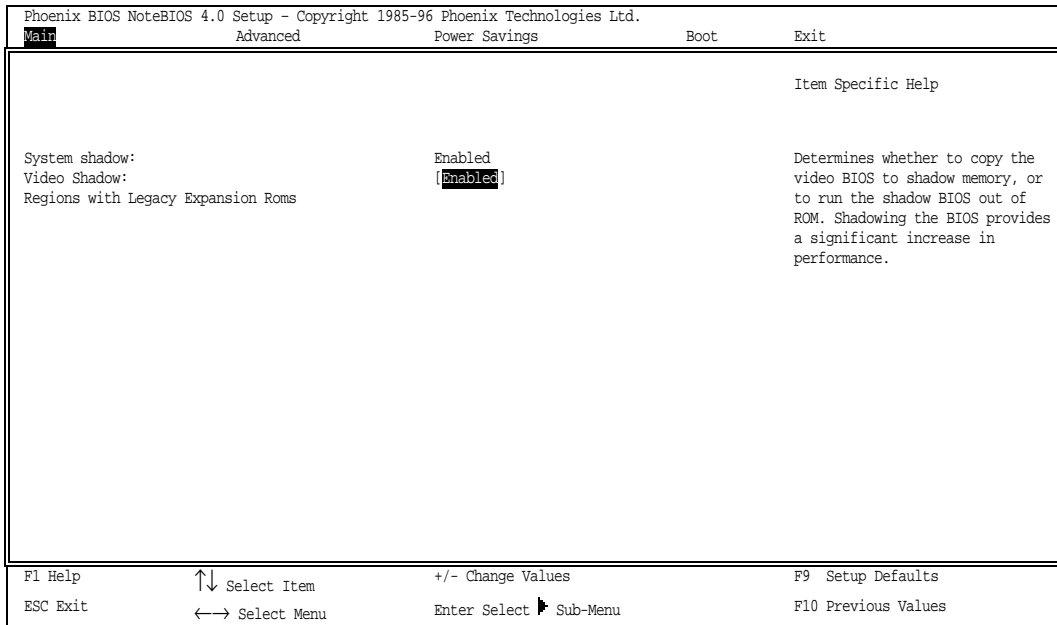

Use the following chart to configure memory shadowing.

Feature	Options	Description
System shadow	N/ A	Permanently enabled.
Video shadow	Enabled Disabled	Determines whether to copy the video BIOS to shadow memory, or to run the shadow BIOS out of ROM. Shadowing the BIOS provides a significant improvement in performance.

CAUTION: Incorrect settings can cause your system to malfunction.

4.2.5 Boot Options

Selecting "Boot Options" on the Main Menu displays the Boot Options menu.

Phoenix BIOS NoteBIOS 4.0 Setup - Copyright 1985-96 Phoenix Technologies Ltd.			
Main	Advanced	Power Savings	Exit
Boot Options		Item Specific Help	
Network Boot ROM:	[Disabled]	Order system searches drives for a boot disk.	
Summary screen:	[Enabled]		
Floppy check:	[Enabled]		
Boot-time Diagnostics Screen:	[Enabled]		
F1 Help	↑↓ Select Item	+/- Change Values	F9 Setup Defaults
ESC Exit	←→ Select Menu	Enter Select ▶ Sub-Menu	F10 Previous Values

Use the following chart to select your boot options.

Feature	Options	Description
Network Boot ROM	Enabled Disabled	Enabled causes BIOS to attempt to boot from network, Disabled causes BIOS to boot from local floppy or hard disks.
Summary Screen	Enabled Disabled	Display system configuration on boot.
Floppy check	Enabled Disabled	Enabled verifies floppy type on boot, disabled speeds boot.
Boot Diagnostics screen	Enabled Disabled	Displays system diagnostic screen during boot.

4.2.6 Keyboard Features

Selecting "Numlock" on the Main Menu displays the Keyboard Features menu:

Phoenix BIOS NoteBIOS 4.0 Setup - Copyright 1985-96 Phoenix Technologies Ltd.			
Main	Advanced	Power Savings	Boot Exit
Keyboard Features			Item Specific Help
Numlock:	[Auto]	Selects Power-on state for Numlock.	
Key Click:	[Disabled]		
Keyboard auto-repeat rate:	[30/sec]		
Keyboard auto-repeat delay:	[1/2 sec]		
F1 Help	↑↓ Select Item	+/- Change Values	F9 Setup Defaults
ESC Exit	←→ Select Menu	Enter Select ▶ Sub-Menu	F10 Previous Values

Use the following chart to configure the keyboard features:

Feature	Options	Description
Numlock	Auto On Off	Selects Power-on state for NumLock.
Key Click	Enabled Disabled	Turns audible key click on.
Keyboard auto- repeat rate	2/ sec 6/ sec 10/ sec 13.3/ sec 18.5/ sec 21.8/ sec 26.7/ sec 30/ sec	Selects key repeat rate.
Keyboard auto- lag delay	¼ sec ½ sec ¾ sec 1 sec	Selects delay before key repeat.

4.3 The Advanced Menu

Selecting "Advanced" from menu bar displays a menu like this:

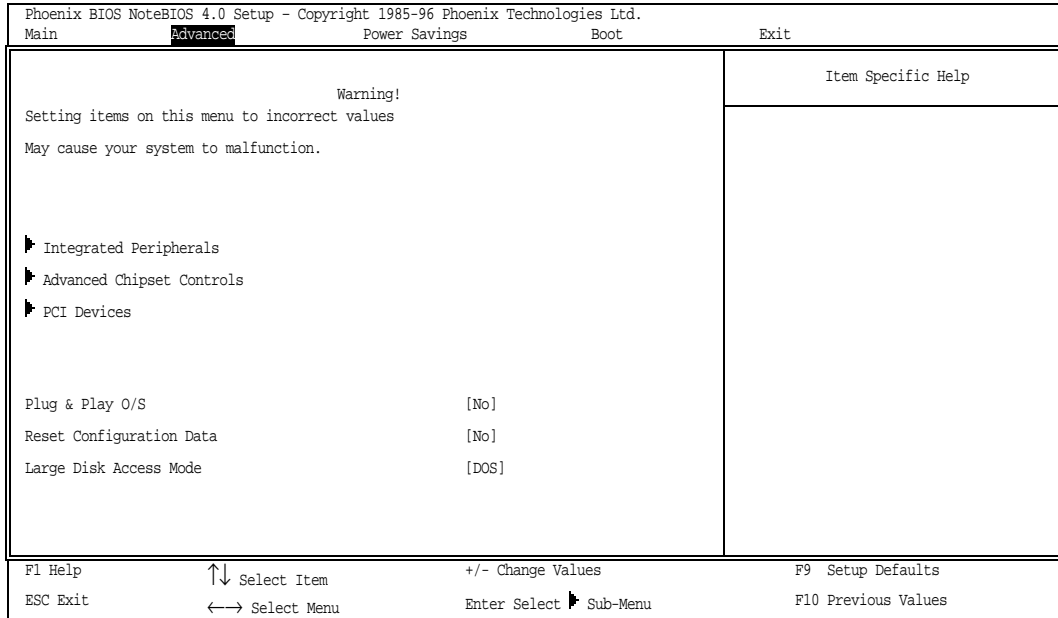

Use the following chart to make your selection:

Feature	Options	Description
Plug and Play OS	Yes No	If your system has a Plug and Play Operating System, Yes lets the Operating System configure Plug and Play devices not required for boot. No makes the BIOS configure them. Select "No" to use the Ethernet controller in Windows 95 or Windows NT.
Reset Configuration Data	Yes No	Yes erases all configuration data in ESCD, which stores the configuration settings for non- PnP plug- in devices. Select Yes when required to restore the Manufacturer's defaults.
Large Disk Access Mode	DOS Other	Select DOS if you have DOS or Windows. Select Other if you have another Operating system such as UNIX. A Large disk is one that has more Than 1024 cylinders, more than 16 Heads, or more than 63 tracks per Sector.

4.3.1 Integrated Peripherals

Selecting "Integrated Peripherals" from the Advanced menu displays this menu:

Phoenix BIOS NoteBIOS 4.0 Setup - Copyright 1985-96 Phoenix Technologies Ltd.			
Main	Advanced	Power Savings	Boot Exit
Integrated Peripherals		Item Specific Help	
UART 1 Port:	[3F8h, IRQ 4]	Set COM A port address and IRQ.	
UART 2 Port:	[2F8h, IRQ 3]		
UART 2 Mode:	[Standard]		
UART 3 Address:	[3E8h]		
UART 3 IRQ:	[IRQ 4]		
UART 4 Address:	[2E8h]		
UART 4 IRQ:	[IRQ 3]		
Parallel Port:	[378, IRQ 5]		
Parallel Port Mode	[Standard Mode]		
Diskette Controller	[Enabled]		
Onboard Audio:	[Enabled]		
Onboard Ethernet:	[Enabled]		
USB Enable:	[Enabled]		
Local Bus IDE adapter:	[Disabled]		
F1 Help	↑↓ Select Item	+/- Change Values	F9 Setup Defaults
ESC Exit	←→ Select Menu	Enter Select Sub-Menu	F10 Previous Values

Use the following chart in configuring the Integrated Peripherals:

Feature	Options	Description
UART 1 Port	Disabled Auto 2E8h, IRQ3 3E8h, IRQ4 2F8h, IRQ3 3F8h, IRQ4	Set COM A port address and IRQ.
UART 2 Port	Disabled Auto 2E8h, IRQ3 3E8h, IRQ4 2F8h, IRQ3 3F8h, IRQ4	Set COM B port address and IRQ.
UART 2 Mode	Standard ASK IR IrDA (HPSIR)	Set the mode for UART 2: Standard, IrDA (HPSIR), Amplitude Shift Keyed @500Khz. If you select one of the IRDA's then another option line appears.
IR Duplex Mode	Full Duplex Half Duplex	Set the Duplex Mode for IR transmission: Full Duplex, Half Duplex.
UART 3 Address	Disabled AE8h BE8h AF8h BF8h 2E8h 3E8h 2F8h 3F8h	Set COM C port address.
UART 3 IRQ	Disabled IRQ 3 IRQ 4 IRQ 5 IRQ 7 IRQ 9 IRQ 10 IRQ 11 IRQ 12 IRQ 14	Set COM C port IRQ
UART 4 Address	Disabled AE8h BE8h AF8h BF8h 2E8h 3E8h 2F8h 3F8h	Set COM D port address.

UART 4 IRQ	Disabled IRQ 3 IRQ 4 IRQ 5 IRQ 7 IRQ 9 IRQ 10 IRQ 11 IRQ 12 IRQ 14	Set COM D port IRQ.
Parallel Port	Auto Disabled 278h, IRQ 7 378h, IRQ 7 3BCh, IRQ 7 278h, IRQ5 378h, IRQ 5 3BCh, IRQ 5 278h, NO IRQ 378h, NO IRQ 3BCh, NO IRQ	Set parallel port address and IRQ.
Parallel Port Mode	Standard Mode Bi-directional EPP Mode ECP Mode	Set parallel port mode
ECP DMA Channel	Disabled DMA 0 DMA 1 DMA 3	Selects the DNA channel ECP will use.
Diskette Controller	Enable Disable	Enables on-board floppy disk controller.
Onboard Ethernet	Enable Disable	Enables the onboard Ethernet controller.
Onboard Audio	Enable Disable	Enables the onboard audio controller.
USB Enable	Disabled Primary	Enables the USB controller.
Integrated Adapter	IDE Disabled Primary Secondary	Enables on-board IDE adapter. N/A for SBC-MaX2

CAUTION: Incorrect settings can cause your system to malfunction.

4.3.2 Advanced Chipset Control

Selecting "Advanced Chipset Control" from the Advanced menu displays this menu:

Phoenix BIOS NoteBIOS 4.0 Setup - Copyright 1985-96 Phoenix Technologies Ltd.			
Main	Advanced	Power Savings	Boot
Advanced Chipset Control			Item Specific Help
Chipset Auto Configuration:		[Enabled]	Advanced chipset features will be automatically set to predefine values every boot.
DRAM Write Wait State:		0	
RAS# precharge time:		3 clocks	
RAS# low to CAS# low delay:		3 clocks	
DRAM Write Buffer Concurrency:		[Enabled]	
FP DRAM W.S. with prefetch buffer:		[7-3-3-3]	
EDO DRAM timing:		[7-2-2-2]	
SDRAM timing:		[8T/7T]	
SDRAM CAS Latency:		[3T]	
SDRAM cycle time:		[9T]	
MW #Cas width/DRAM PostWt Buf:		[1T/X-3..]	
Resource lock for DRAM:		[Disabled]	
PCI address/data stepping:		[Disabled]	
CPU to PCI post-write:		[3T]	
CPU to PCI though Write Buffer:		[Enabled]	
CPU to PCI #NA Function:		[Enabled]	
CPU to PCI Write Buffer:		[8]	
Reduce #RAS W.S. when Bank Miss:		[Disabled]	
Fast Back-To-Back function:		[Disabled]	
VGA Burst Write Wait State:		[0 Wait]	
Send #NA at T2 after each #MemWrt:		[Disabled]	
F1 Help	↑↓ Select Item	+/- Change Values	F9 Setup Defaults
ESC Exit	←→ Select Menu	Enter Select Sub-Menu	F10 Previous Values

The following chart describes each of the options on this menu:

Feature	Options	Description
Chipset Auto Configuration	Enable Disable	Advanced chipset features will be automatically set to predefined values every boot.
DRAM Write Wait State	0 1 2 3	When Auto Configuration is disabled, sets DRAM Write wait state speed.
RAS# precharge time	2 3 4 5	When Auto Configuration is disabled, defines the number of CPU clocks for RAS# signal precharge.
RAS# low to CAS# low delay	2 3 4 5	When Auto Configuration is disabled, defines the number of clocks delay from RAS# asserted to CAS#
DRAM Write Buffer Concurrency	Enable Disable	Control Pipeline Function.
FP DRAM W.S. with prefetch buffer	6-2-2-2 6-3-3-3 7-2-2-2 7-3-3-3	Fast page mode DRAM access timing.
EDO DRAM timing	6-2-2-2 7-2-2-2	EDO DRAM timing control.
SDRAM cycle time	7T/6T 8T/7T	SDRAM 1 st READ latency for page-hit cycle.
SDRAM CAS Latency	2T 3T	SDRAM CAS latency, RAS# to CAS# low delay.
SDRAM Cycle time	7T 9T	SDRAM RAS# active-to-charge and precharge.
MW #Cas width/DRAM PostWt Buf	1T/X-3 1T/X-2 2T/X-3	Setting the timing of Memory write #CAS pulse width and Post Write Buffer to DRAM.
Resource lock for DRAM	Enable Disable	Resource lock for local DRAM.
PCI address/data stepping	Enable Disable	PCI stepping.
CPU to PCI post-write	3T 4T Disabled	CPU to PCI post-write control and wait state.
CPU to PCI though Write Buffer	Enable Disable	CPU to PCI control with Write Buffer.
CPU to PCI #NA Function	Enable Disable	CPU to PCI #NA function.
CPU to PCI Write Buffer	4 8	Setting the CPU to PCI Write buffer width.
Reduce #RAS W.S. when Bank Miss	Enable Disable	Reduce the #RAS precharge time when bank missed.
Fast Back-To-Back function	Enable Disable	
VGA Burst Write Wait State	0 Wait 1 Wait	

Send #NA at T2 after each #MemWrt	Enable Disable
-----------------------------------	-------------------

CAUTION: Incorrect settings can cause your system to malfunction.

4.3.3 PCI Devices

Selecting "PCI Devices" from the Advanced menu displays this menu:

Phoenix BIOS NoteBIOS 4.0 Setup - Copyright 1985-96 Phoenix Technologies Ltd.			
Main	Advanced	Power Savings	Boot
PCI Devices			Item Specific Help
VGA Linear Address Activity:	[Disabled]	Enables VGA Linear address as a activity.	
PCI Auto Configuration:	[Enabled]		
PCI Control:			
Select CPU Clk:	[50 MHz]		
Bus Park:	[Enabled]		
Bus Lock:	[Disabled]		
IO Recovery (BCLK)	[4]		
Diskette Controller	[Enabled]		
Local Bus IDE adapter:	[Both]		
PCI-ISA BCLK Divider:	PCICLK/4		
F1 Help	↑↓ Select Item	+/- Change Values	F9 Setup Defaults
ESC Exit	←→ Select Menu	Enter Select ▶ Sub-Menu	F10 Previous Values

The following chart describe each of the options on this menu:

Feature	Options	Description
VGA Linear Address Activity	Enabled Disabled	Enables VGA Linear Address as an activity
PCI Auto Configuration	Enabled Disabled	Advanced PCI bridge features will be automatically set to predefined values on every boot.
PCI Control	N/A	
Select CPU Clk	50 MHz 60 MHz 66.6 MHz	Select Default CPU clock speed.
Bus Park	Enabled Disabled	
Bus Lock	Enabled Disabled	
IO Recovery (BCLK)	2 4 8 12	
PCI-ISA BCLK Divider	PCICLK/4	Adjustable if PCI auto config. is

	PCICLK/2 PCICLK/3	disabled.
--	----------------------	-----------

CAUTION: Incorrect settings can cause your system to malfunction.

4.4 The Power Savings Menu

Selecting "Power Savings" from menu bar displays a menu like this:

Phoenix BIOS NoteBIOS 4.0 Setup - Copyright 1985-96 Phoenix Technologies Ltd.			
Main	Advanced	Power Savings	Boot Exit
Power Saving: [Off] Idle Mode: [Off] Standby Timeout: [Off] Auto Suspend Timeout: [Off] Hard Disk Timeout: [Off]			Item Specific Help Select Power Management Mode. Choosing modes changes system power management settings. Maximum Power Savings conserves the greatest amount of system power while Maximum Performance conserves power but allows greatest system performance. To alter these settings, choose Customize. To turn off power management, choose OFF.
F1 Help	↑↓ Select Item	+/- Change Values	F9 Setup Defaults
ESC Exit	←→ Select Menu	Enter Select Sub-Menu	F10 Previous Values

The following chart describes each of the options on this menu:

Feature	Options	Description
Power Savings	Off Maximum Performance Maximum Power Savings Customize	Select Power Management Mode. Choosing modes changes system power management settings. Maximum Power Savings conserves the greatest amount of system power while Maximum Performance conserves power but allows greatest system performance. To alter these settings, choose Customize. To turn off power management, choose OFF.
Idle Mode	On Off	Turn on or off the Idle Mode power savings. Idle Mode slows down the CPU during brief periods when the system is not busy.
Standby Timeout	Off 1 Minute 2 Minutes 4 Minutes 6 Minutes 8 Minutes 12 Minutes 16 Minutes	Amount of time the system needs to be in Idle Mode before entering the Standby Mode. Standby Mode turns off various devices in the system, including the screen, until you start using the computer again.
Auto Suspend Timeout	Off 5 Minutes 10 Minutes 15 Minutes 20 Minutes 30 Minutes 40 Minutes 60 Minutes	Amount of time the system needs to be in Standby before entering Suspend Mode.
Hard Disk Drive Timeout	Off 10 Seconds 15 Seconds 30 Seconds 45 Seconds 1 Minute 2 Minutes 4 Minutes 6 Minutes 8 Minutes 10 Minutes 15 Minutes	Amount of time the hard disk needs to be inactive before it is turned off.

4.5 The Boot Menu

After you turn on your computer, it will attempt to load the operating system (such as Windows 95) from the drive of your choice. If it cannot find the operating system on that drive, it will attempt to load it from one or more other drives in the order specified in the Boot Menu.

Note:

Specifying any drive as a boot drive on the Boot Menu requires the installation of an operating system on that drive. To use another drive as a bootable drive may require your installing the operating system on it.

Selecting "Boot" from the Menu Bar displays the Boot menu, which looks like this:

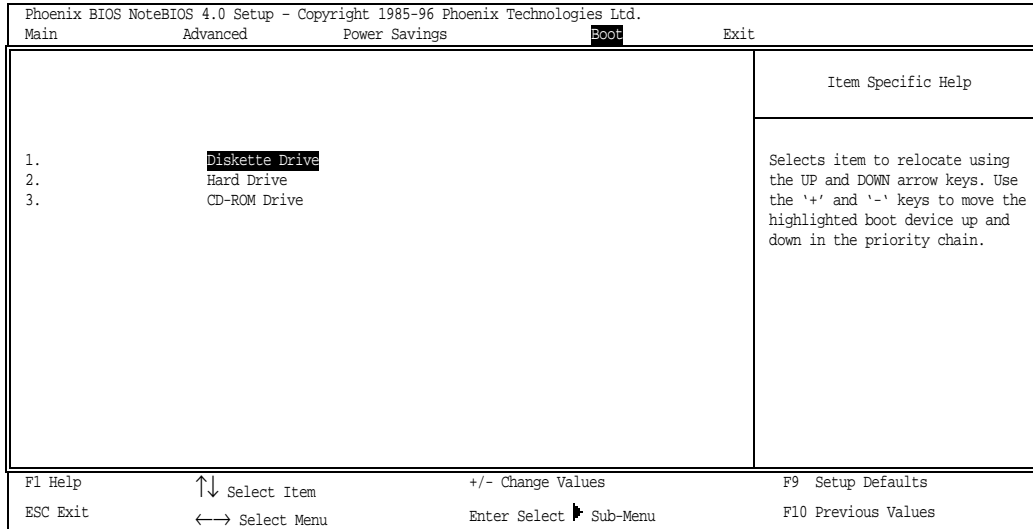

You can arrange the boot order list at the top of this menu to specify the order of the devices from which the BIOS will attempt to boot the Operating System.

To move a device, first select it with the up- or- down arrows, and move it up or down using the <+> and <-> keys.

4.6 The Exit Menu

Selecting "Exit" from the menu bar displays this menu:

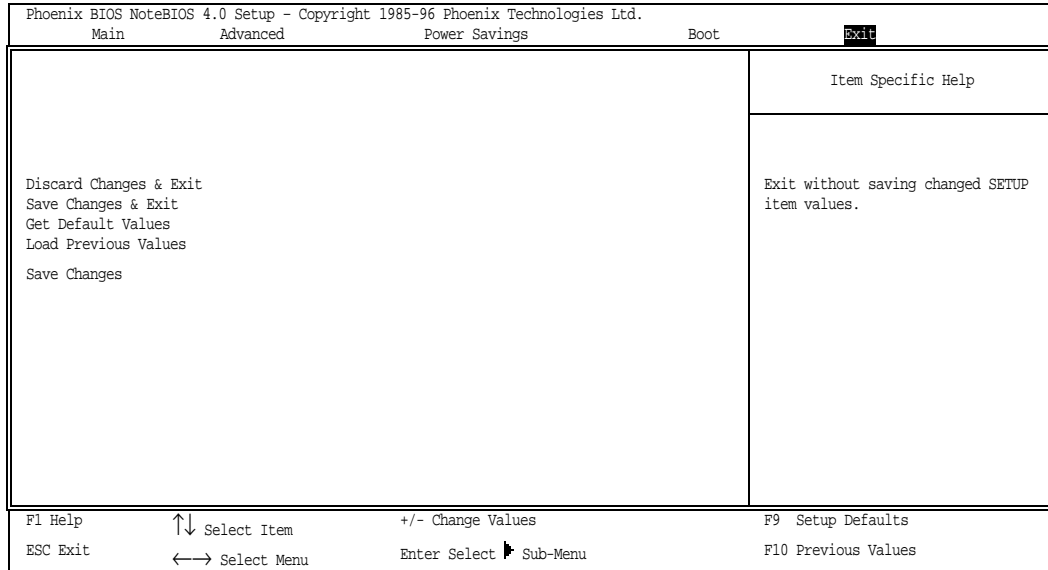

The following describes each of the options on this menu:

4.6.1 Discarding Changes & Exit

Use this option to exit Setup without storing in CMOS any new selections you may have made. The selections previously in effect remain in effect. Pressing <Enter> will exit Setup and reboot the computer.

4.6.2 Save Changes & Exit

After making your selections on the Setup menus, always select "Save Changes & Exit" to store the selections in "battery- backed CMOS RAM". The next time you boot your computer, the BIOS configures your system according to the Setup selections stored in CMOS.

After you save your selections, the program displays this message:

```
Notice
Changes have been saved.
[Continue]
```

If you attempt to exit without saving, the program asks if you want to save before exiting and displays this message:

```
Warning!
Configuration has been not been saved!
Save before exiting?
[Yes] [No]
```

During bootup, Phoenix BIOS attempts to load the values saved in CMOS. If those values cause the system boot to fail, reboot and press <F2> to enter Setup. In Setup, you can get the Default Values (as described below) or try to change the selections that caused the boot to fail.

4.6.3 Get Default Values

To display the default values for all the Setup menus, select "Load Setup Defaults" from the Exit Menu. The program displays this message:

```
Notice
Default values have been loaded.
[Continue]
```

If, during bootup, the BIOS program detects a problem in the integrity of values stored in CMOS.

The program displays this message:

```
System CMOS checksum bad - run SETUP
Press <F1> to resume, <F2> to Setup
```

The CMOS values have been corrupted or modified incorrectly, perhaps by an application program that changes data stored in CMOS.

Press <F1> to resume the boot or <F2> to run Setup with the ROM default values already loaded into the menus. You can make other changes before saving the values to CMOS.

4.6.4 Load Previous Values

To display the previous values for all the Setup menus, select "Previous Values Defaults" from the Exit Menu. The program displays this message:

```
Notice
Previous values have been loaded.
[Continue]
```

4.6.5 Save Changes

Selecting "Save Changes" saves all the selections without exiting Setup. You can return to the other menus if you want to review and change your selections.

The program displays this message:

```
Notice
Changes have been saved.
[Continue]
```

5 TROUBLESHOOTING GUIDE

5.1 Major System Failures

5.1.1 No Response on Power-up

WARNING: High Voltages

HIGH VOLTAGES APPEAR THROUGHOUT THE POWER DISTRIBUTION CIRCUITS. EXTREME CARE SHOULD BE EXERCISED WHEN TESTING ANY LINE POWER VOLTAGES.

1. Check Power Cabling

Visually check Power connectors and cabling for proper installation or any signs of damage.

2. Check Power Supply

Make sure that Power is applied. Make sure that all circuit breakers and switches in line are engaged. Insure the system provides good power grounding.

5.1.2 No Display with Backlight lit

1. Check Temperature

Make sure the display is within operating temperature range. Allow display to cool or warm up as required.

2. Check Video Mode

Make sure that proper video mode has been selected. Reboot into VGA display mode (Safe Mode in Windows95), if video appears, check settings in Control Panel.

3. Check Housing Connections

Make sure that the rear housing is completely secured to the front display. Detach and Reattach the rear housing making sure that the two parts are lined up correctly.

4. Screen saver

If a screen saver has turned off the display, touch the screen to return the display to operation.

5.1.3 No System Boot

1. Check Self-Test Codes

During normal power-up two beeps will sound before system begins booting. Any other combination or longer beep duration indicates a hardware failure. Please return this unit to the factory for repair. Factory technicians must complete further procedures.

2. 'CMOS checksum error' message displayed

CMOS battery has failed. Pressing the DEL key and manually making any changes needed in CMOS Setup will allow use of the system until the battery is replaced. Battery has a normal lifetime of up to 10 years.

Please return this unit to the factory for battery replacement.

3. 'Safe Recovery' message displayed during Windows startup

Occurs on initial power up if the unit had been turned off after last use, without first exiting WindowsNT. The DisplayPAC Access will power up normally.

4. 'Non-System disk error' message displayed

A disk has been left in the Floppy Disk drive. Remove the disk and reboot the system.

5. 'A:>' prompt is displayed

A disk, formatted with system files, has been left in the Floppy Disk drive. Remove the disk and reboot the system.

5.2 Flat Panel Display

5.2.1 Unacceptable Display Image

1. Make sure that all of the latest video drivers have been installed on the computer.
2. Make sure that the proper Resolution and Refresh Rates have been selected on the computer.
3. Adjust Brightness and Contrast for the installation's background lighting.
4. Check Housing Connections

Make sure that the rear housing is completely secured to the front display. Detach and Reattach the rear housing making sure that the two parts are lined up correctly.

5. Please return this unit to the factory for repair. Factory technicians must complete further procedures.

5.2.2 Missing Pixels

NOTE: It is not unusual for a panel to have one or two missing pixels, less than ten are considered acceptable.

1. Please return this unit to the factory for repair. Factory technicians must complete this procedure.

5.2.3 Pixels stuck on

NOTE: It is not unusual for a panel to have one or two pixels stuck on, less than ten are considered acceptable.

1. Please return this unit to the factory for repair. Factory technicians must complete this procedure.

5.3 Display Backlight

5.3.1 Dim or No Backlight

1. Check Temperature

Make sure the display is within operating temperature range. Allow display to cool or warm up as required.

2. Check Housing Connections

Make sure that the rear housing is completely secured to the front display. Detach and Reattach the rear housing making sure that the two parts are lined up correctly.

3. Screen in Direct Sunlight

Change location of display or adjust contrast.

4. Return for backlight replacement.

5.4 Touch Panel

5.4.1 No response from Touch Panel

1. Make sure that all of the latest touchscreen drivers have been installed.
2. Run Touch Screen Utilities | Configuration
3. Choose Calibration and recalibrate the touch panel.

5.4.2 Improper placement of Cursor upon Touch

1. Make sure that all of the latest touchscreen drivers have been installed.
2. Run Touch Screen Utilities | Configuration
3. Choose Calibration and recalibrate the touch panel.

5.5 Accessories

5.5.1 PS/2 Mouse Inactive

1. Check Mouse cable is plugged in and to proper connector.

2. Reset DisplayPac Access Display
3. Substitute another PS/2 Mouse

5.5.2 PS/2 Keyboard Inactive

1. Check Keyboard cable is plugged in and to proper connector.
2. Reset DisplayPac Access Display.
3. Substitute another PS/2 Keyboard.

5.5.3 Printer Inactive

1. Check Printer Cable is plugged in and to proper connector.
2. Printer is Powered up and Online.
3. Make sure proper printer drivers have been installed.
4. Reset DisplayPac Access Display.
5. Substitute another Printer and printer Cable.

5.5.4 Printing Garbled Information

1. Make sure proper printer drivers have been installed.
2. Reset printer and DisplayPac Access Computer.
3. Substitute another Printer and printer Cable.

6 REPAIR PROCEDURES

6.1 Opening the Enclosure

1. Detach the rear housing from the front of the Access computer by pushing the silver clamps, located in the middle of both sides of the rear housing, towards the front of the Access bezel.
2. Unlatch the now loosened retaining clamps from the front housing.
3. Pull the rear housing apart from the front housing by pulling straight back on the rear housing.

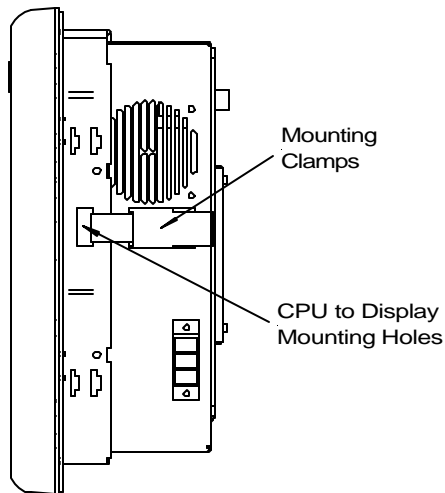

Figure 6-1 CPU to Display Mounting

6.2 Power Distribution

WARNING: High Voltages

***HIGH VOLTAGES APPEAR THROUGHOUT THE POWER DISTRIBUTION CIRCUITS.
EXTREME CARE SHOULD BE EXERCISED WHEN THE ENCLOSURE HAS BEEN OPENED.***

6.2.1 Substitute Power Cable

1. *Make sure that Power has been disconnected.* Power connections are made to a terminal strip located on the side of the unit. To access the terminal strip, remove the side cover. Remove lugs from the terminals marked Line (L), Ground (G), and Neutral (N).

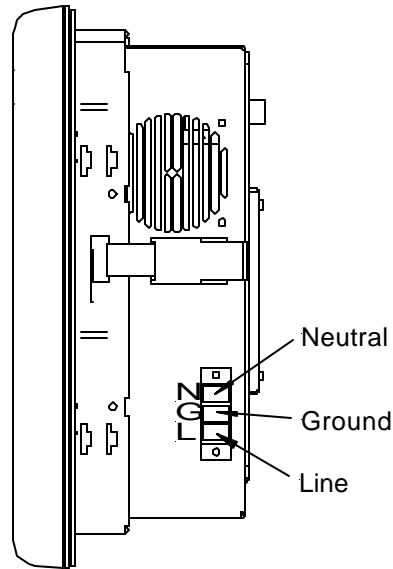

Figure 6-2 Power Connections

6.3 Adding Features

6.3.1 Installing Expansion Cards

To avoid damage from electro-static discharge, adhere to the following precautions when installing expansion cards:

- ❑ The card is packaged in a static-safe bag, which protects the product during shipping. Before removing the card from this bag, be prepared to handle it in a static-safe environment.
- ❑ Wear a properly functioning anti-static strap and be sure that you are fully grounded. Never touch the card, or any components inside the Access computer unless you are wearing an anti-static strap.
- ❑ Any surface the unprotected card is placed on should be static-safe, facilitated by anti-static mats, if possible.

NOTE: There is a maximum power limit of 55 Watts for all expansion slots on the Access models.

6.3.2 PC/104 Card Installation

1. Remove the rear Access CPU housing before the PC/104 plate screws. Otherwise, the internal mounting bar will fall into the unit.
2. The PC/104 expansion slot within the system allows the card to be clamped into place using a clamping bracket with screws adjustable to the height of the card.

WARNING: High Voltages

***HIGH VOLTAGES APPEAR THROUGHOUT THE POWER DISTRIBUTION CIRCUITS.
DISCONNECT THE MAIN POWER BEFORE REMOVING THE REAR COVER FROM THE UNIT.***

3. When the back-plate screws are loosened, the back-plate will slide upwards and can then be lifted clear of the main unit.
4. Any empty slots must have a blanking plate fitted, or the air flow will not comply with agency requirements. The blanking plate can be removed in order to install a new card.

6.3.3 PCI/ISA Card Installation

The Access Expanded Computer provides two dual-purpose ISA/PCI expansion slots (1 & 2) and one dedicated ISA slot (3). All slots fit half-size adapter cards (slot 1 – 8” max, slot 2 – 9.5” max, slot 3 - 10” max). If your expansion card is a legacy ISA type, follow the instructions in the following section, then proceed with installation.

All of the expansion slots within the system allow the card to be clamped into place using a clamping bracket with screws adjustable to the height of the card.

The rear cover of the Access Computer must be removed to access the PCI or ISA bus cards. Five screws are used to secure the rear panel to the unit. When these screws are removed the backplate will slide upwards and can then be lifted clear of the main unit.

WARNING: High Voltages

***HIGH VOLTAGES APPEAR THROUGHOUT THE POWER DISTRIBUTION CIRCUITS.
DISCONNECT THE MAIN POWER BEFORE REMOVING THE REAR COVER FROM THE UNIT.***

6.3.4 Configuring Legacy ISA Cards

Legacy ISA cards are the oldest standard and require memory, I/O, and IRQ settings to be manually set on the card using jumpers, DIP switches, or a configuration program. The card and system need to have the same settings.

CAUTION: For most applications an IRQ or address cannot be shared by more than one resource. If more than one resource is set to the same interrupt or address, the application may not respond properly and could cause your machine to lock up. Following these instructions when installing legacy ISA cards will prevent problems with resource conflict.

1. *Make sure Power is OFF*, open rear cover to expose the ISA and PCI connectors on the PISA riser card.
2. Remove the blank card plate for any slots in which you will install option cards. Remove the Phillips head screw securing the blank plate to the chassis and set aside.
3. Install expansion card into proper slot connector (ISA vs. PCI bus), carefully press into connector until card is fully seated.
4. Reinstall the Phillips head screw, which held the blank plate into place.
5. Replace the rear cover, secure with the latches. Connect any interface cables required by the new expansion card.

6.3.5 Memory Expansion

CAUTION: Make sure to wear an anti-static wrist strap whenever memory is being handled.

NOTE: This applies to the DisplayPac Access computer modules only.

1. *Make sure Power is OFF*, open rear cover to expose the DIMM connector on the motherboard.
2. Remove the existing memory from the DIMM socket by releasing the locks on each end of the socket. Remove the memory stick from the motherboard.
3. Install expanded memory stick into DIMM socket, carefully press into socket until memory is fully seated. Make sure that the DIMM socket locks are both fully engaged.
4. Replace the rear cover, secure with the latches. Reconnect any interface cables removed to do the installation.

6.4 Calibration Procedures

6.4.1 Touchscreen Calibration

NOTE: The cursor may not respond to the touchscreen correctly after system has finished booting for the first time.

1. In Windows95, run Start | Programs | Touch Screen Utilities | Configuration
2. Click "Interface..."
3. Click "Advanced..."
4. Change "Screen Wires:" from 4 to 8 using the pull-down menu.
5. Click "OK" to exit Advanced Controller Option.
6. Click "OK" to exit Interface Configuration Options.
7. Choose "Calibration..." on Configuration Utilities Screen.
8. Choose "Calibrate"
9. Touch the 3 targets as they appear on the screen.
10. The first in the upper left corner, the second in the lower right, and the third in the middle right.
11. Click "OK" to exit calibration screen.
12. Click "Exit" to close Configuration Utility.

6.5 Maintenance Procedures

6.5.1 Changing the Air Filter Element

The air filter element should be changed or cleaned every three months -- sooner in dusty environments. If the air filter is not changed at suitable intervals, or if a non-approved filter is used, the unit may overheat.

CAUTION: Power down the Access Computer before replacing the air filter.

The filter element is located on the outside of unit, on the rear housing back-plate.

1. Pull the plastic cover from the air filter at the back of the computer.
2. Replace the old filter with the new filter.
3. Snap the cover back onto the back plate.

6.5.2 Filter Pads

Filter pads (reference Globe Motors part FFM3145) are available from:

Allied Electronics

Tel: 1-800-433-5700

<http://www.alliedelec.com>

<http://www.globemotors.com>

6.5.3 Changing the Fuse

Access Standard CPU Models have no user serviceable fuse. The following applies only to Access Expanded CPU model.

CAUTION: Power down the Display Station before changing the fuse.

To remove the fuse:

1. Locate the fuse on the side of the rear housing, next to the power cord.
2. Turn the fuse counter clockwise to release it.

To replace the fuse:

1. Insert a new fuse completely into the socket. (2A 250 VAC)
2. Push and turn the fuse clockwise to lock it in place.

APPENDIX

A. MECHANICAL OUTLINES

1. 10" Display, Standard CPU Module

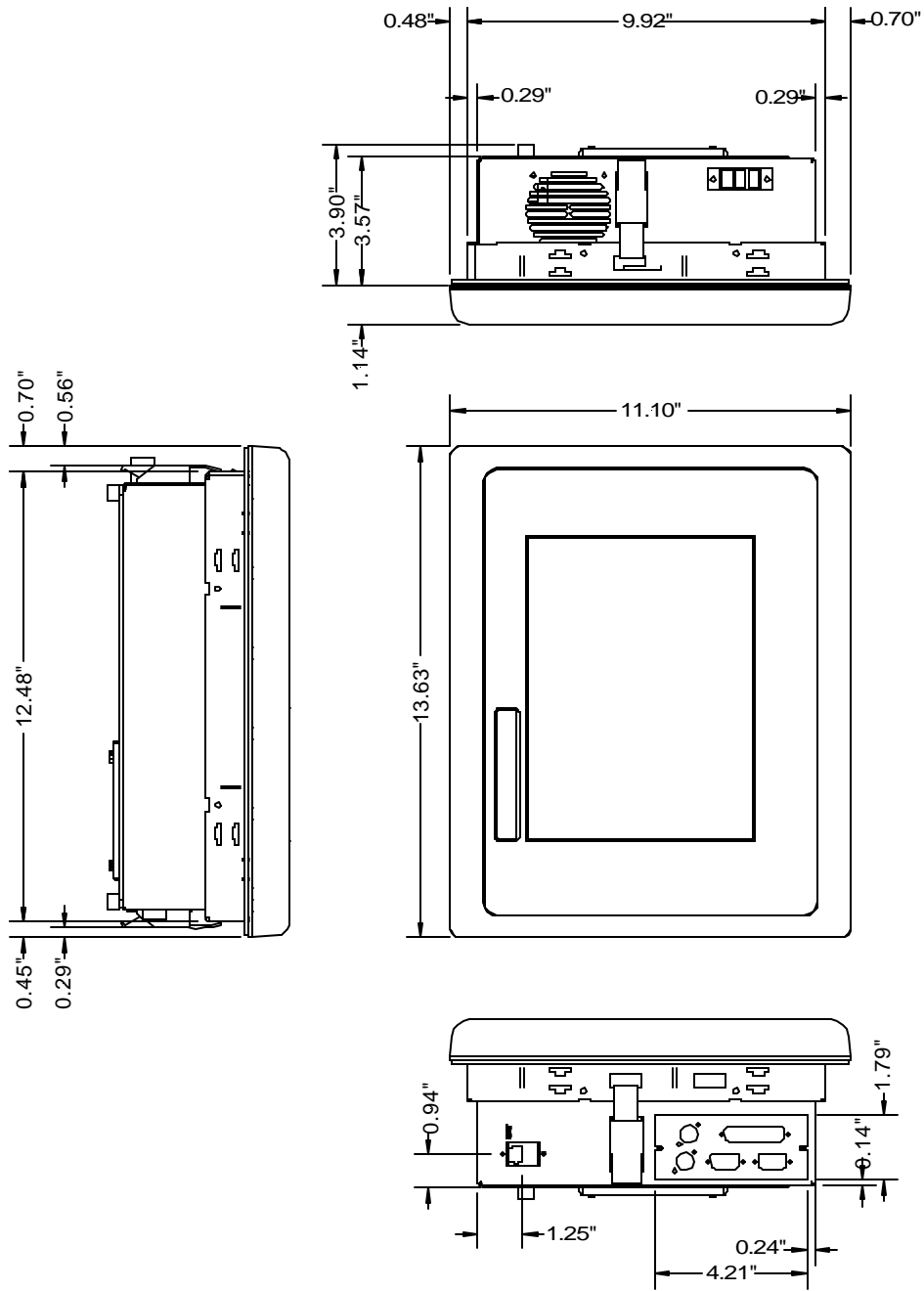

2. 10" Display, Expanded CPU Module

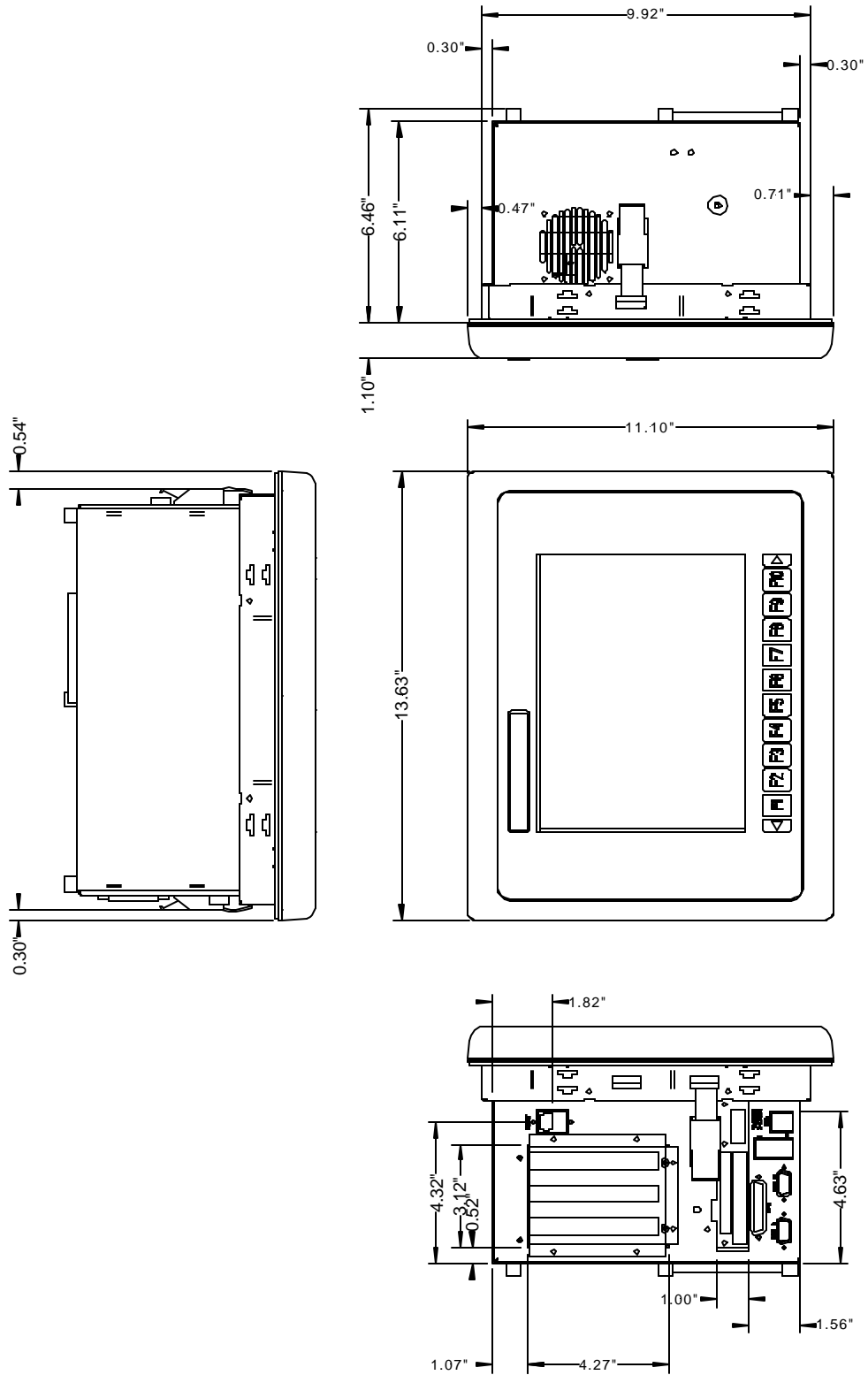

B. TECHNICAL DATA

1. MATING CONNECTORS

Function	CDI Part Number	Manufacturer's Part Number
COM Port	7CRF0-0050-0900	AMP 747905-2
Printer	7CRF0-0025-0000	Krista 24B236
Ethernet	7CRM0-0004-0600	AMP 5-554720-3
PS/2 Keyboard and Mouse	7CRM0-0050-0600	Krista 80-1010
USB	Std. USB Cables	

2. FILTER SPECIFICATIONS

Dimensions	80mm by 80mm (3.15" by 3.15")
Material	Polyurethane foam.
Performance Requirements	Retain 75% by weight of dust particles down to 5-10 microns in size
Temperatures	to 100° C
Flame resistance	BS2963
Part Number	Globe Motors part FFM3145

Available From:

Allied Electronics
Tel: 1-800-433-5700

<http://www.alliedelec.com>
<http://www.globemotors.com>

C. WARRANTY STATEMENT



COMPUTER DYNAMICS INCORPORATED
7640 Pelham Rd., Greenville, SC 29615
Phone: (864) 627-8800

WARRANTY

CDI products are warranted for a period of one year from the date of purchase against all defects in materials and workmanship provided they are properly used and not modified by non-CDI personnel. Subassemblies and items not manufactured by CDI (power supplies, disk drives, etc.) are warranted for the period established by their original manufacturer. CDI will repair or replace the product, provided that it is returned promptly to CDI at the owner's expense. Prior to returning a component or subsystem, the purchaser must obtain a Return Material Authorization number (RMA#) from CDI. All board level products are shipped in an antistatic bag to prevent damage to the electronic components due to electrostatic discharge. Failure to use the bag in shipment will VOID the warranty. No other warranty is expressed or implied.

DISCLAIMER

CDI makes no representation or warranties with respect to the contents hereof and specifically disclaims any implied warranties of merchantability or fitness for any particular purpose. Further, CDI reserves the right to revise the prices or specifications and to make any changes from time to time in the contents hereof without obligation of CDI to notify any person of such revisions or changes.

To Our Customers:

It is our intention to provide you with accurate and useful information about our product. Although the information is correct to the best of our knowledge, we cannot assume responsibility for inaccuracies within the manual.

We request that you inform us of any errors found, areas difficult to understand or suggestions to improve this manual. Please fill out the bottom portion (using additional sheets if necessary) with your comments and return it to CDI.

Thank you.

Name: _____

Computer Dynamics, Inc.

Company: _____

7640 Pelham Rd.

Greenville, S.C. 29615

Phone: (864) 627-8800

Address: _____

Phone: _____

Product Type: _____

Card Serial No. _____

COMMENTS: