

Lucas Control Systems -- Deeco

M9ST

**Serial Graphics/Text Touch Module
Hardware User Manual**

Manual P/N: 13412 (B)

Manual Revision: 2.0

Manual Revision Date: February 1998

How to contact Deeco for sales or technical support:

North America and Asia/Pacific:

Lucas Control Systems -- Deeco

31047 Genstar Road

Hayward, California USA 94544-7831

Phone: 510-471-4700

FAX: 510-489-3500

General E-mail: sales@deeco.com

Technical Support CompuServe: LDTECHSUPPORT@COMPUSERVE.COM

Application Engineering Hotline: 510-476-2551

Internet Home Page: www.deeco.com

Fax-back System: 916-431-6547

Technical Support BBS: 510-471-5402

Baud Rate:	up to 14400 Baud
Data Bits:	8
Parity:	None
Stop Bits:	1
Flow Control:	XON/OFF or hardware
Emulation:	ANSI

Europe:

Lucas Control Systems -- Deeco

Wertstrasse 8

D-73240

Wendlingen, Germany

Phone: 49-7024-9712-14

FAX: 49-7024-9712-40

For Returns - Contact Deeco's customer service for a Return Authorization (RA) number prior to shipping product to the factory. Freight to the factory is prepaid by the customer. Freight return to the customer is paid by Deeco. Ship product in its original packaging or equivalent to prevent transit damage.

Copyright 1998, Lucas Control Systems, part of LucasVarity's Electrical and Electronic Systems division

All rights reserved. Deeco is a registered trademark of LucasVarity. All other trademarks are the property of their respective owners. Information furnished by Deeco is believed to be accurate and reliable. However, no responsibility is assumed by Deeco for its use, nor for any infringements of patents or other rights of third parties which may result from its use. No license is granted by implication or otherwise under any patent rights of LucasVarity.

Printed in the U.S.A.

WARNING!

Grounding circuit continuity is vital for safe operation of the machine. Never operate the machine with grounding conductor disconnected. See installation instructions before connecting to the supply.

The system described in this manual uses an AC power supply capable of producing a dangerous electrical shock. Only properly trained and authorized personnel should work with the module.

WARNING: DISCONNECT POWER BEFORE OPENING.

CAUTION: USE PROPER ESD PROCEDURES SERVICING THE TERMINAL.

Static electricity introduced into the electronics is often not immediately fatal, but can cause future reliability problems - like frequent and troublesome failures.

DO NOT ATTEMPT TO ALTER THE VOLTAGE POTENTIOMETER SETTING ON THE POWER SUPPLY BOARD. IT IS SET PROPERLY AT THE FACTORY AND SEALED. IF THE SEAL IS BROKEN AND THE SETTING ALTERED, DAMAGE TO THE DISPLAY MAY RESULTS AND ALL WARRANTIES WOULD BE VOIDED.

IF IT IS NECESSARY TO DISCONNECT THE DISPLAY PANEL FROM THE CONTROLLER BOARD, WAIT A *MINIMUM* OF TEN SECONDS AFTER POWER DOWN TO AVOID POSSIBLE DAMAGE TO THE DISPLAY PANEL.

READ THE INSTALLATION AND SET-UP SECTION OF THIS MANUAL *CAREFULLY BEFORE* ATTEMPTING TO APPLY POWER TO THE DISPLAY.

Table of Contents

1.0 CONFIGURATION AND SPECIFICATIONS	1
1.1 PRODUCT SUMMARY	1
1.2 ORDERING INFORMATION	2
1.3 M9 SPECIFICATIONS.....	3
2.0 INSTALLATION	5
2.1 UNPACKING.....	5
2.2 MOUNTING	6
2.3 APPLYING POWER	7
2.3.1 <i>Power Requirements</i>	7
2.3.2 <i>Internal Power Connections</i>	9
2.4 POWER-UP MESSAGES	10
2.5 HOST INTERFACE CONNECTION.....	11
2.6 TESTING THE M9ST	14
2.7 TROUBLESHOOTING A NEW UNIT	25
2.8 SELF-TEST.....	26
2.9 BAUD RATE.....	26
2.10 DATA FORMAT	26
3.0 INPUT/OUTPUT INTERFACE PORTS	27
3.1 SERIAL COMMUNICATIONS PORTS	28
3.2 KEYBOARD CONNECTOR.....	30
3.2.1 <i>KEYBOARD INTERFACE OPERATION</i>	30
4.0 TERMINAL CONFIGURATION	33
4.1 SET-UP SCREENS VS. SET-UP JUMPERS	33
4.2 SET-UP JUMPERS.....	33
4.2.1 <i>Host Port</i>	34
4.2.2 <i>Serial Mode Select</i>	34
4.2.3 <i>RS485 Configuration</i>	35
4.2.4 <i>Display Select</i>	35
4.2.5 <i>Non-Volatile Memory Enable</i>	35
4.2.6 <i>Aux Memory</i>	36
4.2.7 <i>Power-Up Mode</i>	37
4.3 ENTERING AND LEAVING SET-UP	38
4.4 SET-UP MENUS	38
4.4.1 <i>General Setup Menus</i>	39
4.4.2 <i>Display</i>	40
4.4.3 <i>Printer</i>	40
4.4.4 <i>Keyboard</i>	41

4.4.5 Communications.....	41
4.4.6 Touch.....	42
5.0 IR TOUCHSCREEN.....	43
5.1 INTRODUCTION.....	43
5.1.1 Capabilities.....	43
5.2 SPECIFICATIONS.....	43
5.3 MAINTENANCE.....	44
5.3.1 Effects of Chemicals on the SealTouch Bezel/Filter.....	44
6.0 COMMUNICATIONS & INTERFACES.....	47
6.1 SERIAL HOST INTERFACE OPERATION.....	47
6.1.1 Data Format.....	51
6.1.2 Handshake Techniques.....	51
6.1.3 RS485 Multi-Drop Communications.....	51
6.1.3.1 RS485 Set-Up Fields.....	53
6.1.3.2 RS485 Operations.....	53
6.1.3.3 Host Commands.....	55
6.1.3.4 Internal Baud Rate.....	55
7.0 TROUBLESHOOTING AND REPAIR.....	59
APPENDIX A: MECHANICAL DRAWINGS.....	63
A.1 JUMPER AND CONNECTOR LOCATION.....	63
A.2 PROPORTIONAL FRONT VIEW.....	64
A.3 BEZEL MOUNTING EXPLODED DRAWING.....	65
A.4 FRONT VIEW DRAWING.....	66
A.5 SIDE VIEW DRAWING.....	67
A.6 CUTOUT DRAWING.....	68
A.7 EMI FRONT PANEL CUTOUT.....	69
A.8 EMI FRONT PANEL.....	70
A.9 EMI SIDE VIEW.....	71
APPENDIX B: ORDERING/CUSTOMER SUPPORT.....	73
B.1 ORDERING.....	73
B.2 CUSTOMER SUPPORT.....	73
APPENDIX C: PRODUCT NAMING CONVENTION.....	75
APPENDIX D: ADDITIONAL DOCUMENTATION.....	77
LIMITED WARRANTY.....	79
INDEX.....	81

1.0 Configuration and Specifications

Lucas Control Systems, Deeco offers a complete line of sealed and unsealed standalone computers, panel mount computers, monitors, and serial terminals. All computers and modules are available with touch systems - a rugged and intuitive user interface. Deeco has manufactured flat panel display based products for harsh and industrial applications for more than a decade.

1.1 PRODUCT SUMMARY

The M9 series VT100 style text mode terminal modules combine Deeco's SealTouch® IR touch controller technology with flat panel displays. When properly mounted, the display and touch system are sealed to NEMA 4/12 (IP65) specifications.

Features



- VT100 emulation: 80 characters x 25 rows of text.
 - Deeco pixel graphics: includes commands for drawing lines, circles, arcs, block color, pattern fills, and concave or convex object fills. Firmware provides button commands for auto-draw, pop-up menus, multiple touch modes, programmable touch sensitivity, and continuous screen touch error monitoring.
-
- On-board intelligence: touch data analysis is performed at the terminal, graphic drawings are triggered by simple commands, and custom configurations are saved at the terminal.
 - Deeco's Touch Assist application development software minimizes the time it takes to write application programs. It makes designing menus fast and easy. Also, Touch Assist creates touch buttons that will automatically send commands out the serial port when the screen is touched.

1.2 ORDERING INFORMATION

Base System Configuration

- M9ST EL monochrome, Amber filter**
VT100 style text mode, Deeco Pixel Graphics, 640 x 400 EL display with front panel NEMA 4/12 (IP65) when mounted. Includes 32K EEPROM standard, upgradable to 128K. RS232, RS422, or RS485 interface.
- M9STXT EL monochrome, Amber filter, Extended Temperature**
VT100 style text mode, Deeco Pixel Graphics, 640 x 400 EL display with front panel NEMA 4/12 (IP65) sealed when mounted. Includes 32K EEPROM standard, upgradable to 128K. Temperature range: -25°C to +60°C. RS232, RS422, or RS485 interface.
- M9ST-8C 8.4" AM color LCD**
VT100 style text mode, Deeco Pixel Graphics, 640 x 480 8.4" diagonal display with front panel NEMA 4/12 (IP65) when mounted. Includes 32K EEPROM standard, upgradable to 128K. Viewing area is 171 mm x 130 mm. RS232, RS422, or RS485 interface.

Upgrades and Options

Memory

- 1602 128K EEPROM
- 1604 128K SRAM

Power Supply and EMI Options *a

- AC 100-240VAC autosensing input power supply
- 8126 AC Line Filter
- AC 6ft Power Cord
- 24V +20 to +36VDC power supply option
- EMI Shielded to MIL-461C-A2b at the front

Software

- 805 Touch Assist II - Touch Interface Software Development Tool for C4 emulation
- 822 Touch Assist IV - Touch Interface Software Development Tool for Color mode
(Only available with M9ST-8C)

<h3>Special Ordering Information</h3> <p>*a If power supply is not order the user must provide a +12VDC and +5VDC.</p>
--

1.3 M9 SPECIFICATIONS

Displays	M9ST 600 x 400 pixel EL monochrome, amber M9ST-XT 600 x 400 EL, extended temp. M9ST-8C 8.4" Active Matrix color LCD
Emulation	VT100, VT320, VT220, VT52
Viewing and Touch Area Dimensions	7.68" W x 4.8" H (195 mm x 122 mm)
Connectors	Power Conn: 8-pin IDC connector Parallel port data connector: 26-pin flat Serial host port: 25-pin male D-sub socket Serial printer port: 9-pin male D-sub socket Keyboard connector: 5-pin
Inputs/Outputs	RS232C RS422 with optical isolation RS485 multidrop with optical isolation Parallel Port Serial printer/AUX Serial Port IBM Keyboard Port
Memory	32K EEPROM standard, upgradable to 128K
Baud Rates	Parallel, 300 to 38400 (set by jumper or NVM)
Diagnostics	Self-test on power-up; IR beam array, board logic, and state memory parameters.
Touch Modes	Up to 121 Discrete Touch Zones; Up to 121 Button Pages; Enter, Exit, Track Reporting; X-Y Coordinate Reporting; Pop-up Menus; Qwerty, ABC, Numeric/Function Keyboards
Weight	8.0 lbs (3.6 kg)

Dimensions 6.9" H x 10.5" W x 2.1" D
(175 mm x 267 mm x 55 mm)

Ratings NEMA 4/12 (IP65) sealed front bezel

Temperature	Operating	Non-operating
EL	0°C to +55°C	-20°C to +80°C
EL (XT)	-25°C to +60°C	-20°C to +80°C
LCD	0°C to +45°C	-20°C to +60°C

Shock 10G 50G

**Vibration
@ 5-500Hz,
sine sweep** 1.0G rms 3.0G rms

Humidity 5-95% RH, non-condensing

Power Input +24 VDC or 100-240 VAC input
+5 VDC for controller logic and +12 VDC for display voltage converter if no
power supply is selected

**MTBF
(nominal)** Controller > 80,000 hours
Display > 45,000 hours
(@25°C)

Note: AMTFT display backlights are considered field replaceable items, and are not included in MTBF figures.

2.0 Installation

2.1 UNPACKING

The shipping container includes the Deeco SealTouch module, power cord and manual. Check for any visible damage to the terminal, and contact the shipper if any damage is found.

Shipping configuration varies with options selected. This is a representative shipping list:

- The M9ST Serial Graphics/Text Touch Module
- This M9ST Hardware User Manual.
- A separate Firmware User Manual
- A gasket for sealing the M9ST into an opening
- Power pigtail (if -AC or +24 VDC power supplies are not ordered)

If the 100-220 VAC power supply is ordered, a AC line cord and AC line filter can be selected as options. If the optional +24 VDC is ordered, or if no power supply is ordered, construct a power cable using the information in section 2.3.

Actual shipping configuration is documented on the packing list, located on the outside of the shipping carton. Lucas Deeco customer service maintains a record of customer shipping configurations.

Observe ESD Precautions When Unpacking and Handling the M9ST

If you are using the M9ST for the first time, a touch button tutorial is included in the accompanying C4 Firmware manual.

2.2 MOUNTING

The M9ST is designed to be mounted to a cutout in a front panel. Refer to Appendix A for recommended panel cutout and standoff locations. Appendix A also includes detailed information on the dimensions and physical layout of the M9ST. These drawings will assist the user in integrating the M9ST into the intended enclosure.

Installing the M9ST into a panel:

- Make a cutout template according to the cutout diagram in the Appendix A6.
- Make a cutout at the location where the M9ST is to be mounted.
- For the standard mounting configuration there are 6 mounting holes around the perimeter of the M9ST. These holes facilitate the use of #4-40 screws to mount the unit to the rear of the panel. Mount the module to the panel while making sure that the gasket is properly aligned. If the gasket is improperly installed, an effective NEMA 4/12 rated seal will not be achieved.

Consult Applications Engineering (510-476-2551) for assistance in mounting the optional EMI shield.

2.3 APPLYING POWER

2.3.1 Power Requirements

Input Voltage	Display	Max Current Draw
+5VDC, +12VDC (no power supply)	STD	+5VDC, 2A; +12VDC, 2A
	SBBL/UBBL	+5VDC, 8.0A; +12VDC, 4.0A
+24VDC	STD	3.3A
	SBBL/UBBL	6.7A
115VAC	STD	2.5A
	SBBL/UBBL	2.5A

Once the terminal module has been properly connected to the host system, the user is ready to apply power to the unit.

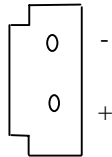

A Molex series 2400 header, 09-57-1085 or equivalent, and a pigtail wiring harness is shipped separately when no power supply is ordered. Use the 2400 series header to connect J2 to the pigtail. Connect so the yellow, red, and black wire colors match, not the pin numbers. Connect to the 14" pigtail as follows:

Power Input at Pigtail	
Voltage	Wire Color
+12 @ 2.0 Amp	Yellow
+5V @ 2.0 Amp	Red
	NC
Return (ground)	Black
No Connect	Orange

The power supply must regulate to $\pm 3\%$ on +5V and $\pm 5\%$ on +12V, over a range of 20%-100% of the maximum load. Input current ratings are approximate.

If using RS-422/485 do not use the pigtail, instead, connect at J2, and supply +5V Isolated and Isolated Return.

2.3.2 Internal Power Connections

Voltage requirements are typically +5 VDC for the controller logic and +12 VDC for the display voltage converter. The display voltage must not exceed +15 VDC or it will damage the serial interface on the controller, thus voiding the warranty. It is very important to have clean power at the correct levels. Failure to have correct power can result in irregular operation or possible failure.

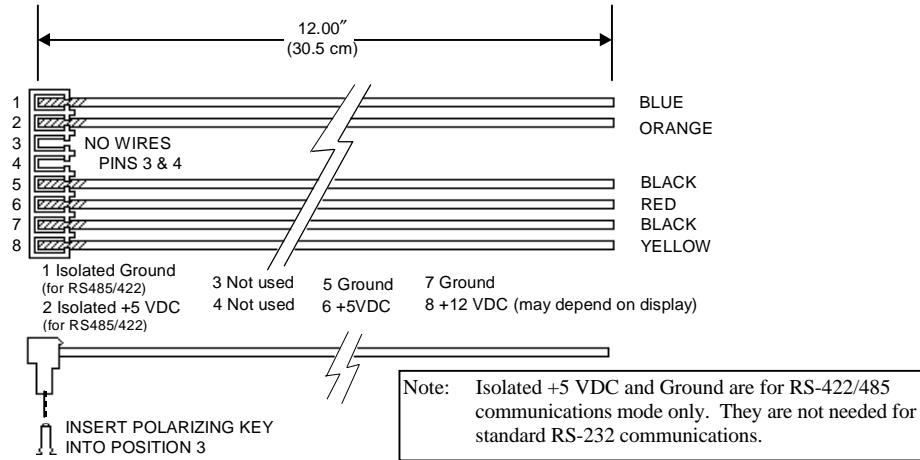

Internal Power Cabling at J1

IN CASE OF DIFFICULTY - CHECK VOLTAGES ON THE DEECO CONTROLLER BOARD TO ENSURE PROPER POWER—NOT AT THE SOURCE.

2.4 POWER-UP MESSAGES

Once proper connections have been established, apply power to the module. Do not make contact with the touch area of the screen until the terminal has completed its self test and initialization routine. Any touch during this phase may be interpreted as a failed I-R beam.

The M9ST performs a variety of tests upon power-up and reports the results via messages on the screen. The messages displayed on the screen will remain for approximately two seconds, then disappear. The M9ST reports its self-test results on the first line of the display. The message:

SELF TEST OK

will indicate that all tests passed. The message:

SELF TEST FAIL: XX

will indicate that one or more of the self test diagnostics failed.

XX	Test
01	ROM Checksum
02	System RAM
04	IR Subsystem

Test Bit Relationship

Two or more failures are indicated by a summation of error codes. For example, ROM checksum and system RAM errors would be indicated by a value of 03 (01 + 02).

The M9ST will also report where it obtained its default operating modes. The defaults may be retrieved from non-volatile memory or be specified by jumpers. The following messages may occur:

CONFIGURATION BY STATE MEMORY

This message will appear when the default operating modes have been stored in non-volatile state memory. It indicates that the state information has been successfully retrieved without error.

STATE MEMORY ERROR: NVM CHECKSUM INVALID

This message indicates that an attempt to use the non-volatile state memory values failed. The data in the non-volatile memory was most likely lost. The defaults used will be determined by factory defaults and switch settings.

STATE MEMORY CHANGES: STATE DEFINITION

An attempt to use the non-volatile state memory values failed. The data in the non-volatile memory is intact, but the system has determined that it is insufficient.

The cause of this message is usually a new software revision that has changed the definition of "STATE" by either adding or subtracting information from it. The defaults used will be determined by factory defaults and switch settings. This will appear the first time new software is added, and should not appear again after the next time power is cycled.

STATE MEMORY CHANGES: SWITCH PRIORITY

An attempt to use the non-volatile state memory values failed. The data in the non-volatile memory is intact, but the configuration jumpers have changed since the state was stored. The new switch settings will be given priority. The defaults used will be determined by factory defaults and switch settings.

2.5 HOST INTERFACE CONNECTION

Connect the M9ST to your host computer or modem via the standard D-Sub 25-pin male connector on the back of the terminal using RS232, RS422, or RS485 connections. The connection described in this section is the RS232 serial type (since it is relatively simple it is therefore recommended for the first-time set-up).

IBM PERSONAL COMPUTERS RS232 CONNECTIONS

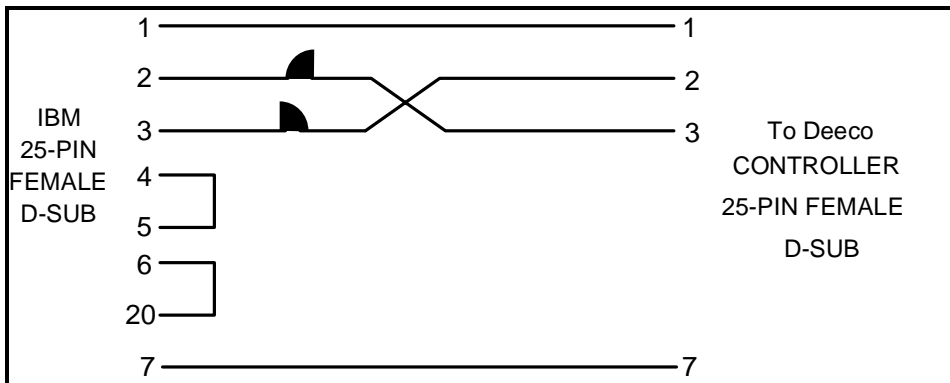

IBM PC/XT RS232 Connections

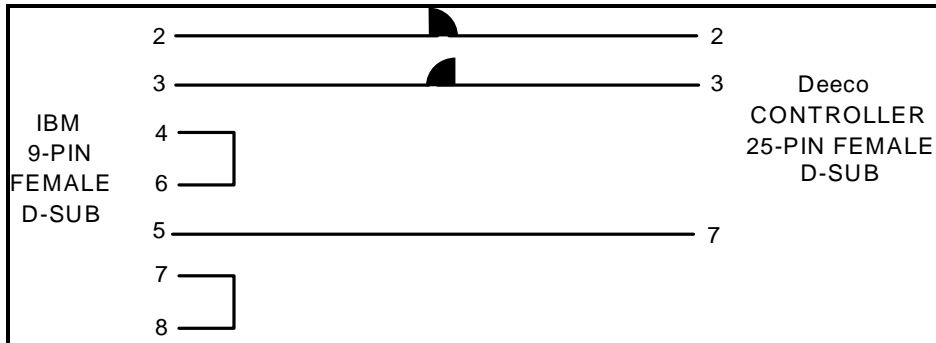

IBM-AT RS232 Connections

Standard Deeco wiring is as follows:

Pin	Signal
Pin 2	Transmit
Pin 3	Receive
Pin 7	Ground

IBM PC Serial Cables

There is no hardware handshaking in this scheme, so use XON/XOFF software to control data flow. XON/XOFF software protocol can be activated or deactivated via the set-up screen as detailed in section 4.4.5.

The XON/XOFF capability is only available on DOS versions 3.0 or higher. If you do not have the capability in your DOS, then implement it in your applications program or there will be problems sending large files of graphics commands.

For DEC computers, a simple 3-wire connection is recommended, as shown below. Handshaking should be accomplished in software using the XON/XOFF protocol. This is the normal default on the M9ST terminal, as it is on the DEC system.

DEC COMPUTER RS232 CONNECTIONS

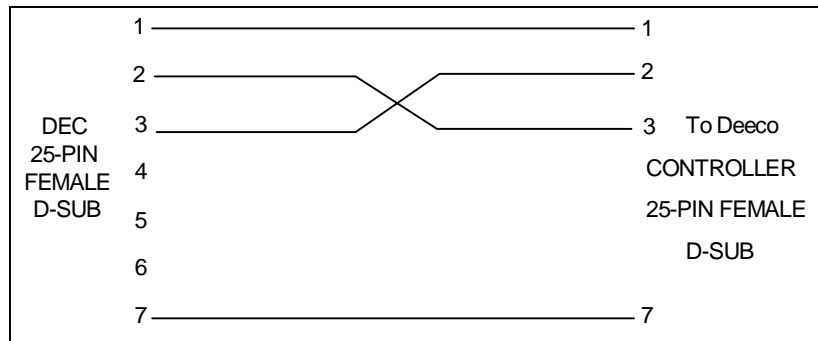

DEC Serial Cable

The same connections can be used with a simple external terminal such as a VT220 instead of a computer.

Since the command language of the M9ST is ASCII encoded, commands may be entered directly from an external terminal keyboard. However, some control codes will be trapped inside the external terminal.

2.6 TESTING THE M9ST

This section was written and tested with an older ST-2200 terminal. Operation of the M9ST is similar to the terminal described here.

Apply power. After about 15 seconds the screen displays the message, "SELF-TEST OK". The screen saver option blanks the display after about 3 minutes of inactivity. A touch to any point on the screen restores the display.



Accessing the QWERTY Keyboard By Touching The Lower Right Corner of the Touch Screen

Touch the lower right corner of the touch screen. A standard QWERTY keyboard appears in the lower half of the screen, as shown above.

Touching a key on the QWERTY keyboard outlines the key with a square, and the terminal beeps. Under the default configuration, characters do not appear in the upper left corner of the screen where the cursor blinks.

When the “Pad” key in the upper right corner of the keyboard is touched, a function keyboard appears. Touching the “SetUp” key in the top row of this Pad keyboard accesses the SetUp menu, as shown below.



Accessing The SetUp Screen from the Pad Screen

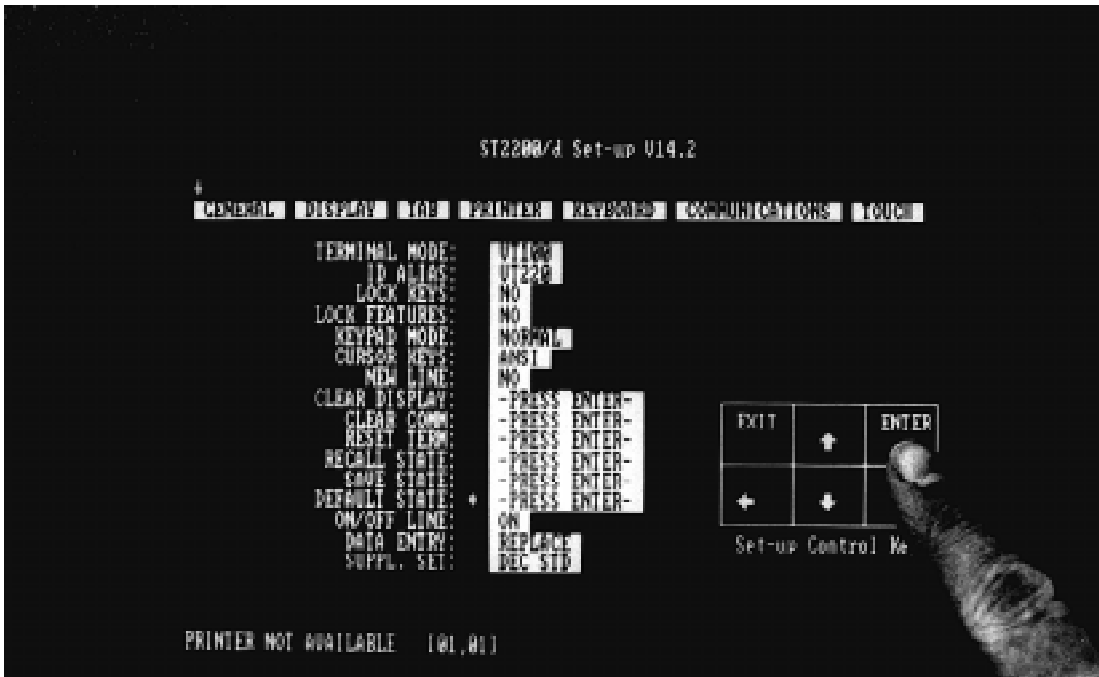

Using The Setup Screen To Restore The Terminal To The Default State

Nearly every option in the SetUp menu can be accessed by sending commands through the serial port.

Testing the Touch System:

Use the left or right SetUp Control Keys to move the blinking arrow to the “TOUCH” button.

Use the down SetUp Control Key to move the blinking arrow to “X-Y ENTER”.

Press the “ENTER” button to change the “X-Y ENTER” state from “OFF” to “ON”.

Pressing the “EXIT” key blanks the screen except for the flashing cursor in the upper left corner.

Touch the screen at any point, and a rectangle will indicate the touch entry point.



Testing The Touch Screen

Cycling the power to the SealTouch terminal will return SetUp to the last saved state. SetUp can be returned to the factory “DEFAULT STATE” in the “GENERAL” SetUp menu.

PC Serial Communications Software Selection

Terminal programs such as PROCOMM® and the Windows™ Terminal Accessory can be used to communicate between a PC computer and the touch terminal. However, these programs do not display all the control characters that will be sent to the terminal. Obtain HOST, a time saving PC serial communications software package from Lucas Deeco. Later we will use one of HOST's features to send files to the touch terminal.

HOST is available at no charge on the Lucas Deeco Bulletin Board. Connection information is available on the front page of this manual. Lucas Deeco publishes an extensive written guide to the bulletin board.

PC Cabling

Customers require different length serial cables, constructed according to this diagram:

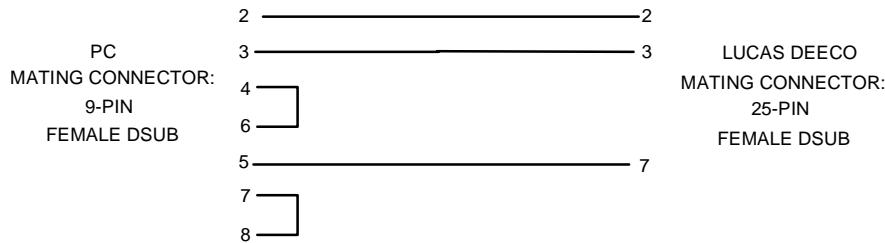

Most commercial serial laplink type cables will connect the 9-pin DSUB serial output of the PC to the 25-pin DSUB serial input of the SealTouch terminal.

PC Configuration & Communication

Most PCs have a single 9-pin serial connector. If the system has a serial mouse, the mouse cable is plugged into this connector. The 9-pin serial connector is often designated as COM1. Check the BIOS set-up screen of the computer to determine the COM assignments of the serial ports.

Remove the mouse or any other device from the 9-pin DSUB connector. Re-boot the computer to free the COM port.

Connect the serial communications cable between the PC and the SealTouch terminal.

Open the SetUp menu on the touch terminal.

Use the left or right SetUp Control Keys to move the blinking arrow to the "GENERAL" button.

Use the down SetUp Control Key to move the blinking arrow to "DEFAULT STATE".

Press the "ENTER" button.

Use the down SetUp Control Key to move the blinking arrow to "SAVE STATE".

Press the "ENTER" button.

Run HOST from DOS.

Any character typed on the PC will appear on the SealTouch Terminal.

To display more than one line of text, move to the DISPLAY menu in SetUp, and change AUTO-WRAP to ON

In case of trouble:

Exit HOST by pressing F10.

Type MSD at the DOS prompt.

COM 1 parameters (set by HOST) must be as follows:

Baud Rate: 9600

Parity: None

Data Bits: 8

Stop Bits: 1

These parameters must be met to communicate with the touch terminal's default SetUp COMMUNICATIONS parameters.

The default DOS serial port setting is 1200 baud. If HOST is not used, the serial port should be set using the DOS MODE command:

MODE COM1:9600,N,8,1

Where COM1 is replaced with COM2 if the second serial port is used.

Use HOST. It's easier and faster.

Pressing the “Kybd” key on the Pad keyboard moves to the touch terminal’s standard QWERTY keyboard.

Any character pressed on the standard QWERTY keyboard will appear on the PC screen.

To see the characters pressed on the standard QWERTY keyboard appear on the touch terminal, set LOCAL ECHO in the COMMUNICATIONS SetUp menu to ON.

Sending Commands to the Touch Terminal

Sending commands to the touch terminal is easy. The touch terminal Firmware User Manual lists the many commands available. The commands begin with ESC, CSI, or DCS.

Sequence Introducers	Keyboard Characters
ESC	ESC
CSI	ESC [
DCS	ESC P

To send a CSI, press the **ESC** key, located in the upper left corner of the keyboard, then type the left bracket ([) key. To send a DCS, press the **ESC** key, then the capital **P** key. Press the two keys sequentially, not at the same time.

To return the SetUp parameters to the saved state, send this sequence:

ESC c

```
HOST DRIVER Version 1.51, Written by Dan Miller

Any characters typed will be sent to the target machine.
Any characters received from the port will be echoed here.
Type 'host /?' at the DOS prompt, for command-line summary.

Special keys:
F1 = Clear screen/Home cursor. (Deeco IR terminals only)
F2 = Send text file to target.
F3 = Send Hard Reset to target. (Deeco IR terminals only)

F4 = Send CSI to target.
F5 = Send DCS to target.
F6 = Send ST to target.

F9 = Stream data to target.
F10 = EXIT from this program.

Serial Parameters: COM1: 9600,8,N,1, IRQ=default
Software handshaking is enabled
Transmit inter-character delay = 0 milliseconds
+c
```

Sending ESC c From a PC, With HOST

Don't type any spaces between the characters.

Do type a lower case c. Commands are case sensitive.

If the terminal is properly processing command strings this sequence resets the touch terminal and SELF-TEST is executed. It is a good idea to periodically send this command when working from the keyboard.

To set AUTO WRAP ON, send this sequence from HOST:

ESC[?7h

HOST will stream data to the display when the **F9** key is typed, and stop streaming data when any other key is pressed. This is an easy way to test auto wrap.

To set AUTO WRAP OFF, send this sequence from HOST:

ESC[?71

Be sure to type a lower case L.

Creating Command Files and Sending Files to the Terminal

Most problems sending command sequences to the touch terminal are caused by mis-typing. It is more efficient to construct and send files to the touch terminal than to key command sequences directly. Most text editors (not word processors) can be used to construct serial command sequence files. The MS-DOS Editor is one such text editor.

Type EDIT at the DOS prompt to access the MS-DOS Editor.

The MS-DOS Editor sees the **ESC** character as a control character, and so will not ordinarily record a command sequence. Holding the **Ctrl** key while pressing the **P** key alerts the editor that the next key stroke is to be recorded.

This sequence will create and send a file to the touch terminal:

ACTION	TYPE	RESPONSE
Change to the directory where HOST is located.	CD\HOST	C:\HOST
At the DOS prompt, type EDIT	EDIT	MS-DOS Editor comes up
	Press ESC key	UNTITLED
Alert editor to record the next keystroke. Hold the Ctrl key and simultaneously press the p key.	Ctrl p	none
	Press ESC key	←
	Press [key	←[
	Press 7	←[7
Command sequence for reverse video entered. Use lower case m.	m	←[7m
Save as	alt f	menu pulls down
	a	Save As Menu
Enter the file name (No extension is necessary)	REVERSE	
	Press the Enter key	REVERSE becomes name of file
Pull down file menu	alt f	
Exit MS-DOS Editor	x	C:\HOST
Start HOST from the DOS Prompt	HOST	
Press the F2 function key	F2	“Enter ANSI text filename...”
Enter name of file to send	REVERSE	
	Press the Enter key	sending REVERSE
Type characters on the PC keyboard		Characters typed within HOST now appear as reverse video on the terminal

ESC [27m will change to normal video, or sending an **ESC c** will reset the touch terminal to the initial state and restore normal video.

Practical Hints

Most problems are caused by mis-typing command strings. If a command string is unrecognized, the SealTouch terminal ignores it, and executes the next valid command string.

If a reset (**ESC c**) is sent in a file, the touch terminal will miss the next several characters of the message while performing self test.

Sending an erase screen command (**CSI 2 J**) erases touch buttons from the screen but not from the touch terminal's memory.

If the top row for is used for touch buttons, cursor movement will affect the box outlines.

Further Developments:

This tutorial is contained in new versions of the accompanying firmware manual, and continues with examples of touch buttons and local response.

Touch Assist software is available from Lucas Deeco - use Touch Assist for the easiest full scale application development.

2.7 TROUBLESHOOTING A NEW UNIT

Ensure proper power is connected to the unit. If it is an AC unit verify that the line voltage is 90-260 VAC, 47-63Hz. If it is a +24 VDC unit verify that the proper voltage is present. The voltage should be checked with the unit connected and power turned on.

Touch the bottom right hand corner of the touch screen to bring up the on-screen keyboard.

Touch the key labeled PAD to enter the set-up screen.

Manipulate the cursor arrow control keys until the pointer is aligned with the DEFAULT STATE choice under the GENERAL menu selection.

Press the ENTER key.

Manipulate the cursor arrow control keys until the pointer is aligned with the SAVE STATE choice under the GENERAL menu selection.

Press the ENTER key.

Press the EXIT key.

Connect the terminal to a standard PC via the serial port. Be sure to use the appropriate wiring scheme. See section 2.5.

Use any standard communications program, such as Terminal in Windows, to set the following parameters:

- 9600 baud
- 8 data bits
- 1 stop bit
- no parity

Establish two-way communications with the terminal. If you do not have a communications program for testing, download the program named HOST from the Lucas Control Systems bulletin board - call 510-471-5402. You can verify two-way communications by typing on your PC keyboard and observe the characters as they appear on the terminal screen. Transmission in the opposite direction is established by entering characters on the terminal's on-screen keyboard.

NOTE: Reverse the Transmit and Receive lines (see pins 2 and 3) if communications cannot be established. This can be done by swapping the wires or by placing a Null Modem in-line with the terminal.

If there is some doubt if the interface works properly, set it into the RS422 mode and make two loopback lines, 12 to 24 and 13 to 25. All keyboard touches should appear on the screen.

This test does not apply to RS485 single channel mode.

Refer also to the Frequently Asked Questions appendix in the accompanying C4 Firmware manual.

2.8 SELF-TEST

The M9ST includes a built-in self-test that verifies functionality. The on screen keyboard and set-up menus can be accessed while in the test mode.

To activate the self test routine, install a jumper on E16 on the controller board. E15 should remain open. Apply power to the unit and observe the self test program displayed on the screen. If

SELF-TEST OK

appears, then the unit is working. Remove jumper E16 before proceeding.

2.9 BAUD RATE

Baud rates can be specified by jumpers or by set-up screens, depending on the state of jumper E9. To select baud rates by jumpers on the M9ST, E9 should be open. If E9 is open, the state of jumpers E1, E2, E3 determine the baud rate. Refer to section 4.2.1 for details.

2.10 DATA FORMAT

The data format of the M9ST is fixed, unless the set-up screens are used. Assure the host system is set to the same protocol.

Default Data Format
1 START BIT 8 DATA BITS 1 STOP BIT NO PARITY

3.0 Input/Output Interface Ports

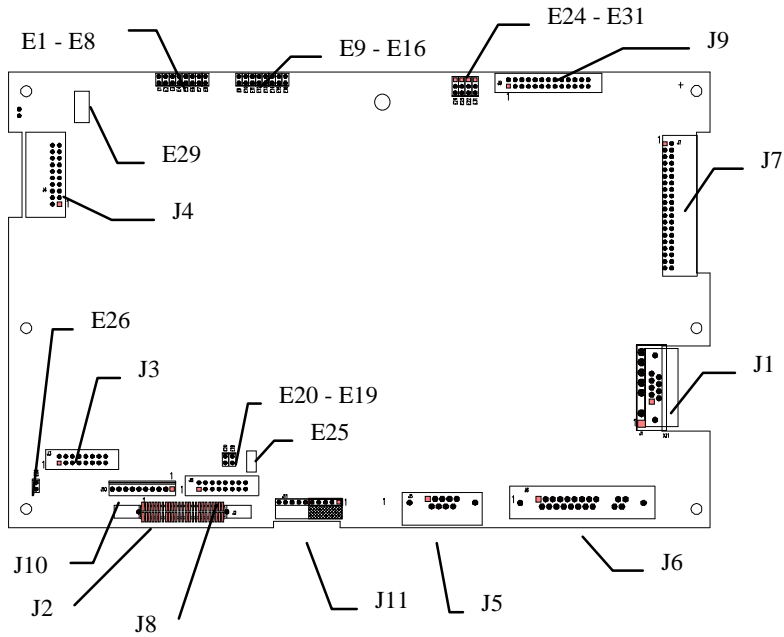

- | | |
|----------------------|-----------------------|
| J1 Power Connector | J7 Touch Interface |
| J2 Display Interface | J8 Display Interface |
| J3 VGA Video | J9 Parallel Port |
| J4 Touch Interface | J10 Backlight Power |
| J5 Printer Port | J11 External Keyboard |
| J6 Host Serial Port | |

Rear View of the M9ST, Without Optional Power Supply

3.1 SERIAL COMMUNICATIONS PORTS

The 9 pin DSUB serial connector DOES NOT have the standard PC pin-out.

It is usually used as a serial printer connector.

PIN	SIGNAL	MNEMONIC	DESCRIPTION
1	Chassis Ground	CGND	Connect to large pad at lower right corner of PC board. This can be connected to the user's system chassis ground, if needed.
2	Transmit Data	TxD	(Output) Transmits serial data. Held low during idle. If hardware handshake is enabled, data is only sent when DSR, CTS and DCD are high.
3	Receive Data	RxD	(Input) Receives serial data.
4	Request to Send	RTS	(Output) High when terminal ready to transmit.
5	Data Terminal Ready	DTR	(Output) Follows RTS. No DTR handshaking supported.
6	Data Set Ready	DSR	(Input) If hardware handshake is enabled, data is sent by the terminal when this line is high.
7	Signal Ground	SGND	Signal ground reference.

The 25 pin DSUB serial connector DOES NOT have the standard PC pin-out.

PIN	SIGNAL	MNEMONIC	DESCRIPTION
1	Chassis Ground	CGND	Connected to large pad at lower right corner of PC board. This can be connected to the user's system chassis ground, if needed.
2	Transmit Data	TxD	(Output) Transmits serial data. Held low during idle.
3	Receive Data	RxD	(Input) Receives serial data.
4	Request to Send	RTS	(Output) Held low when the M9ST is unable to accept data.
5	Clear to Send	CTS	(Input) When low the M9ST will not transmit.
6	Data Set Ready	DSR	(Input) Ignored.
7	Signal Ground	SGND	Ground reference for RS232C and modem control signals.
8	Data Carrier Detect	DCD	(Input) Ignored.
12	Alternate Receive	ALT RCV*	(Input) Alternate receive data for optional communications protocol (RS422, etc.) Not used for RS485 single channel mode.
13	/Alternate Receive	/ALT RCV*	(Input) Alternate receive data for optional communications protocol (RS422, etc.) Not used for RS485 single channel mode.
20	Data Terminal Ready	DTR	(Output) Follows RTS. No DTR handshaking supported.
24	Alternate Transmit	ALT XMT*	(Output) Alternate transmit data for optional communications protocol (RS422, RS485 etc.) Used for RS485 single channel mode.
25	/Alternate Transmit	/ALT XMT*	(Output) Alternate transmit data for optional communications protocol (RS422, RS485 etc.) Used for RS485 single channel mode.

* These signals are also called:

/ALT RCV	RxD A or RxD -
ALT RCV	RxD B or RxD +
/ALT XMT	TxD A or RxD -
ALT XMT	TxD B or TxD +

For the tables above, "high" refers to a voltage of about +12V and "low" a voltage of about -12V on the RS232 cable.

3.2 KEYBOARD CONNECTOR

A special port is available on the M9ST for connecting an IBM PC AT compatible keyboard. Scan codes received from the keyboard are converted to ASCII code before transmission to the host, or they may be sent directly, in the scan code format.

ONLY IBM PC-AT COMPATIBLE KEYBOARDS WILL FUNCTION PROPERLY.

The keyboard connector on the M9ST controller board is a simple 5-pin connector which will mate with the keyboard DIN connector.

Keyboard adapter cable for keyboard (P/N 6700) available as an option.

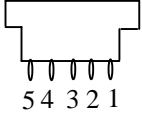
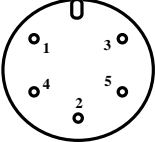
Keyboard Connector	Pin Signal	
	1 KeyClk	
	2 KeyData	
	3 Reset	
	4 GND	
	5 VCC	

M9ST Keyboard Connection Pinout

3.2.1 KEYBOARD INTERFACE OPERATION

The keyboard interface is designed to work with the IBM PC AT keyboard or any functional equivalent. Data is transferred serially with its own clock, and comes not in an ASCII format but rather in a special IBM scan code. To assist the user, the display controller can be set to convert the IBM scan code to the ASCII format before sending it to the host.

IBM PC AT compatible keyboards are widely available from manufacturers such as Hi-Tek, Oak, Keytronics, etc. The keyboard may be used in either a mapped or unmapped mode. In the unmapped mode the key scan codes are sent directly to the host uninterpreted by the M9ST.

When mapped, the codes sent to the host are ASCII where possible and where ASCII is not possible (such as function keys) a unique ANSI 3.64 sequence will be sent to identify the key. Included in the sequence will be information about the current state of the shift keys SHIFT, CTRL, and ALT.

ASCII-possible keys will send the ASCII code of the character indicated by the key's legend. Typing CTRL in conjunction with the key will produce the ASCII code ANDed with 9F hex to produce an ASCII control code. Using the ALT key will result in the ASCII code ORed with 80H to produce full 8-bit codes.

The non-ASCII keys **SCROLL LOCK** and **BREAK** may be used to affect the host communication. **SCROLL LOCK** will act as a toggle to send an XOFF or XON. **BREAK** will issue a 'break' on the RS232 communication line.

The key **SYSREQ (PRINT SCREEN)** is a toggle which will select or deselect the on-screen set-up mode.

4.0 Terminal Configuration

The M9ST set-up screens allow examination or changes to functions such as baud rate, cursor style, and printer port settings. The set-up jumpers determine parameters such as the display type and power up mode. Jumpers can be used to override the set-up screen settings.

4.1 SET-UP SCREENS VS. SET-UP JUMPERS

Set-up screen selections can be stored in non-volatile memory. These saved settings can be recalled at power-up time and used as the initial state of the terminal. To use the stored set-up settings as the initial power-up state the jumper E9 must be in place.

If the jumper E9 is not in place, the initial state of the terminal is determined by a combination of the factory default state and jumpers E1 through E5, which control the host port configuration.

4.2 SET-UP JUMPERS

Jumpers E1 through E16 are referred to as the set-up jumpers. They are distributed throughout the board and normally are factory set.

NOTE: '1' denotes jumper present

'0' denotes jumper absence

4.2.1 Host Port

Baud rates can be specified by jumpers or by set-up screens and the non-volatile memory (NVM), depending on the state of E9. To select baud rates by jumper, E9 should be open. If E9 is open, the state of jumpers E1, E2, E3 determine the baud rate and Table 4-1 applies.

E3	E2	E1	BAUD RATE
0	0	0	Parallel
0	0	1	300
0	1	0	1200
0	1	1	2400
1	0	0	4800
1	0	1	9600
1	1	0	19200
1	1	1	38400

Table 4-1 Baud Rate Jumper Select

4.2.2 Serial Mode Select

The selection of RS232 or RS422/485 is made with the set-up screens, when E9 is jumpered. When E9 is not jumpered, E4 selects between the RS232 and RS422/485 protocols according to Table 4-2. If RS422/485 is enabled with E4, E5 selects the full (E5 open) or half (E5 closed) duplex option.

The serial host port has the capability of using RS232, RS422, or RS485 multidrop formats. The RS422 and RS485 signals appear on a separate set of pins.

E4	Alternate RS485 Communications
1	RS485/422
0	RS232

Table 4-2 RS232/485 Mode Jumper Select

4.2.3 RS485 Configuration

Jumper E5 controls whether the M9ST will operate using full duplex or half duplex while using RS485 serial communications.

E5	RS485 Duplex
1	Half Duplex
0	Full Duplex

Table 4-3 RS485 Duplex Mode Jumper Select

4.2.4 Display Select

The display type is controlled by the jumpers E6 through E8 and E10. These jumpers are typically factory set and need not be changed.

4.2.5 Non-Volatile Memory Enable

Jumper E9 is the non-volatile memory enable. When present, the terminal uses the data found in its non-volatile memory to determine its initial operating state. The host port jumpers E1 through E5 are ignored when E9 is present.

E9	Function
1	Enabled
0	Disabled

Table 4-4 Non Volatile Memory Jumper Selection

4.2.6 Aux Memory

Jumpers E11-E14 are used to specify the size and type of Auxiliary Memory installed, as shown in the following tables. Auxiliary memory is used to store user programs in the form of display lists.

Jumpers		Function
E12	E11	Memory Size
0	0	8 Kbytes
0	1	32 Kbytes
1	0	64 Kbytes
1	1	128 Kbytes

Jumpers		Function
E14	E13	Device Type
0	0	Flash
0	1	EEPROM
1	0	SRAM
1	1	EPROM

Aux Memory Jumper Selection

4.2.7 Power-Up Mode

The jumpers E15 and E16 determine the power-up mode of the terminal. There are four possible power up modes: normal, autoexecute, self-test, and demo. In autoexecute mode the M9ST executes display list #0 prior to accepting commands from the host.

Self-test mode causes the M9ST to perform a self-test repeatedly, all host input is ignored. The demo mode is reserved for future use. Typically the normal mode is used.

E16	E15	Power-Up Mode
1	1	Demo
1	0	Self-Test
0	1	Auto Execute List O
0	0	Normal

Power-Up Mode Jumper Selection

4.3 ENTERING AND LEAVING SET-UP

The set-up menus, or screens, are accessible from either the optional keyboard or the on-screen keyboard.

If the optional hardware keyboard is used, pressing the ‘SysRq’ (Print Screen) key in the top row will enter set-up. This key has a toggle-type operation and hitting it while in set-up mode will cause an exit from set-up mode.

If the optional keyboard is not used, the set-up screens can be accessed via the touch keyboard. To bring the keyboard onto the screen, touch the bottom right-hand corner of the display. The on screen keyboard will appear (provided the keyboard is not disabled by a host computer command). Touch the button labeled “Pad” and the function pad keyboard will appear. To enter the Set-Up menu, touch the “Set-Up” button on the function pad keyboard.

To exit set-up, touch the “Exit” button located near the bottom right corner of the set-up screen grouped together with the “Enter” and arrow keys.

4.4 SET-UP MENUS

Once in the set-up screens, the main menu has six choices, GENERAL, DISPLAY, PRINTER, KEYBOARD, COMMUNICATIONS, and TOUCH. The arrow above the main headings show which group is selected. The GENERAL selection is selected upon entering set-up. The selections below the Main Menu headings can be changed by using the UP/DOWN arrow to position the pointer to the desired item and touching the “Enter” key on the numeric keypad.

4.4.1 General Setup Menus

Feature	Setting	Description
RECALL STATE	ACTION	Sets all features to their saved values.
SAVE STATE	ACTION	Saves all current feature settings.
DEFAULT STATE	ACTION	Returns all features to their factory default settings.
CLEAR SCREEN	ACTION	Clears the text screen and returns the cursor home.
ON LINE	<i>ON (Default)</i> OFF	On-line, communicates with host. Off-line, sends keyboard data to screen
AUTO EX 0	<i>NORMAL (Default)</i> LIST 0 TEST DEMO	Normal operation. Execute display list 0 on start-up. Self-test made. Reserved for future use.
VIEWPORTS ENABLED	<i>NO (Default)</i> YES	Viewport feature disabled. Viewports enabled.
SYSTEM EMULATION	<i>VGA (Default)</i> C4 Emulation	Use full color capability of VGA. Draw buttons, pop-ups, flash regions in XOR mode; limited color capability.
NOTIFY BAD BEAM ENABLED	<i>NO (Default)</i> YES	No notification to host from terminal will be made. Terminal will send bad beam notification message to host.
BEEP BAD BEAM TIME	<i>000 (Default)</i> ENTER TIME	Terminal will not beep upon beam failure. By pressing "Enter" the user can select the total time period that the terminal will beep to alert that a bad beam has been detected (1-60 minute intervals).

4.4.2 Display

Feature	Setting	Description
AUTO-WRAP	<i>ON (Default)</i>	Causes characters received after the right margin to automatically appear in first character position of the next line.
	OFF	Causes characters received after the right margin to be over-written into the last character position of the current line.
CURSOR ON	<i>ON (Default)</i>	Displays text cursor.
	OFF	Text cursor is not displayed.
CURSOR STYLE	<i>BLOCK (Default)</i>	Displays block-style cursor.
	UNDERLINE	Displays underline-style cursor.
TEXT UNDERLINE	<i>NO (Default)</i>	Do not use underline for text.
	YES	Draw underlined text.
SCREEN SAVER	<i>ON (Default)</i>	Programmable screen saver enabled (see SCREEN SAVER TIME-OUT).
	OFF	Screen saver disabled.
SCREEN SAVER RESET ON RECEIVE	<i>ON (Default)</i>	Reset screen saver when data is received via serial port.
	OFF	Leave screen saver active when data is received.

4.4.3 Printer

Feature	Setting	Description
EXTENT	<i>SCREEN (Default)</i>	Print screen commands will print the full screen.
	SCROLL	Print screen commands will only print the scroll area.
TERMINATOR	<i>NO (Default)</i>	No form feed sent at the end of a print page operation.
	YES	Form feed sent at the end of a print page operation.
PR TO HOST	<i>NO (Default)</i>	Printer may not send data to host.
	YES	Printer may send data to host.

4.4.4 Keyboard

Feature	Setting	Description
NEW LINE	<i>YES (Default)</i>	The RETURN key sends a CR and LF. Received LF also performs CR.
	NO	The RETURN key sends a CR only.
KEY MAPPING	<i>YES (Default)</i>	Mapping will ASCII encode all keys.
	NO	Allows scan codes to pass to host
AUTO REPEAT	<i>YES (Default)</i>	Pressing a key sends the character repeatedly until released.
	NO	Pressing a key sends the character only once.

4.4.5 Communications

Feature	Setting	Description
NETWORK	<i>OFF (Default)</i>	Networking inactive.
	ON	Networking active. When networking is active, the terminal ceases to respond to received data or transmit data such as key depressions. Certain commands received will enable or disable the terminal as a LISTENER (able to respond to received data), or TALKER (able to transmit data). The network commands use the ID to designate a particular terminal as a talker or listener. The network commands are always monitored, even if the terminal is not designated as a listener. See the description of these commands for further details.
THIS ID	ENTER ID <i>(Default = 000)</i>	To enter a network ID, press "ENTER." The ID field will go to normal video. Enter the desired ID and press "ENTER." See RS485 multi-drop for detail.
NEXT ID	ENTER ID <i>(Default = 000)</i>	To enter a network ID, press "ENTER." The ID field will go to normal video. Enter the desired ID and press "ENTER."
BAUD	75	Set communication port baud rate.
	110	
	150	
	300	
	600	
	1200	
	2400	
	4800	
	<i>9600(Default)</i>	
	19200	
38400		

Feature	Setting	Description
DATA BITS	8 (Default) 7	Set communications port for 8-bit data. Set communications port for 7-bit data.
PARITY	NONE (Default) EVEN ODD	No parity sent or checked. Even parity sent and checked. Odd parity sent and checked.
STOP BITS	1 (Default) 2	1 stop bit. 2 stop bits.
XON/XOFF	YES (Default) NO	Sends XOFF when input buffer reaches 80% capacity. Disables automatic XON/XOFF flow control.
IO TYPE	RS232 (Default) RS485, 2 CHNL RS485, 1 CHNL Parallel	Selects IO type to be RS232C, data lines only. Selects IO type to be RS485, 2 channel. Selects IO type to be RS422. Selects parallel port as I/O type.

4.4.6 Touch

Feature	Setting	Description
X-Y ENTER	OFF (Default) ON	X-Y enter mode disabled. X-Y enter mode enabled.
X-Y EXIT	OFF (Default) ON	X-Y exit mode disabled. X-Y exit mode enabled.
X-Y TRACK	OFF (Default) ON	X-Y track mode disabled. X-Y track mode enabled.
X-Y HIGHLIGHT	OFF (Default) ON	X-Y highlight mode disabled. X-Y highlight mode enabled.
X-Y BEEP	ON (Default) OFF	X-Y beep mode enabled. X-Y beep mode disabled.
BUTTON ENTER	ON (Default) OFF	Button enter mode enabled. Button enter mode disabled.
BUTTON BEEP	OFF (Default) ON	Button beep mode disabled. Button beep mode enabled.

5.0 IR Touchscreen

5.1 INTRODUCTION

The SealTouch infrared touch sensor provides a user-friendly input device. The flexibility and simplicity of this type of input device makes it the most attractive and least intimidating of all general purpose computer input devices.

5.1.1 Capabilities

The SealTouch infrared touch sensor has three basic methods of reporting user touches. These methods are described below:

The first method simply reports the X-Y coordinates of the center of the user's finger. There are four independent modes within this method. These allow reporting of entry, exit, tracking, and multiple touch (error).

The second method, user defined buttons, detects touches within any rectangular region on the screen and reports back a user-defined message. A very useful (default) mode automatically draws a boundary around the region on the screen and labels this "button" with the message to be sent or, optionally, with a different label. To facilitate rapid menu changes, the sensor can support multiple pages of button definitions and can switch among them with a single command.

The third method of operation allows the program to overlay the screen with a standard keyboard layout, and to report touches as if they were typed on a keyboard. This allows a user to enter specific information, names, passwords, etc., without having to have a separate keyboard available. This keyboard can be made to appear under software control or, if the software permits, under user control.

It is possible to use all three of these methods concurrently by enabling those desired. There is a hierarchy which causes the on-screen keyboard to override the user-defined-buttons, which in turn overrides coordinate reporting.

5.2 SPECIFICATIONS

Scan rate	2500 Hz
Touch resolution	80 x 60
Number of buttons	121 max.
Number of menus	121 max.

5.3 MAINTENANCE

The bezel and filter are made of an acrylic material, so strong solvents should not be used for cleaning purposes. A soft, lint-free cloth, along with a non-abrasive, non-acidic cleaner can be used to clean the touch screen. No special maintenance procedures are required to keep the touch screen operating properly, except to keep the bezel reasonably clean.

5.3.1 Effects of Chemicals on the SealTouch Bezel/Filter

The following table provides a list of chemicals and their effect on acrylic plastic after 7 days immersion at 77° F (25° C).

Class	Name	% Solution	Effect	
Acids	Acetic Acid	100	Dissolves	
	Chromic Acid	40	Discolors	
	Citric Acid	10	Negligible	
	Hydrochloric Acid	38	Attacks	
	Hydrochloric Acid	10	Negligible	
	Nitric Acid	40	Attacks	
	Nitric Acid	10	Negligible	
	Oleic Acid	Any	Negligible	
	Sulfuric Acid	98	Dissolves	
	Sulfuric Acid	30	Negligible	
	Bases	Ammonium Hydroxide	28	Negligible
		Sodium Carbonate	20	Negligible
		Sodium Hydroxide	60	Negligible
Commercial	Cottonseed Oil	Any	Negligible	
	Detergent Solution	Any	Negligible	
	Kerosene No. 2 D396	Any	Negligible	
	Lacquer Thinner	Any	Dissolves	
	Mineral Oil	Any	Negligible	
	Soap Solution	Any	Negligible	
	Transformer Oil D1040	Any	Negligible	
	Turpentine D13	Any	Attacks	

Class	Name	% Solution	Effect
Inorganic Compounds	Distilled Water	Any	Negligible
	Hydrogen Peroxide	28	Negligible
	Sodium Chloride	10	Negligible
	Sodium Hypochlorite	5	Negligible
Organic Compounds	Carbon Tetrachloride	Any	Attacks
	Dibutyl Sebacate	Any	Negligible
	Diethyl Formimide	Any	Swells
	Acetone	Any	Dissolves
	Aniline	Any	Dissolves
	Benzene	Any	Dissolves
	Ethyl Acetate	Any	Dissolves
	Ethyl Alcohol	95	Dissolves
	Ethyl Dichloride	50	Absorbs 2%
	2-Ethylhexyl Sebacate	Any	Dissolves
	Heptane	Any	Negligible
	Isooctane	Any	Negligible
	Methyl Alcohol	Any	Attacks
	Phenol (Aqueous)	5	Attacks
	Toluene	Any	Dissolves

6.0 Communications & Interfaces

6.1 SERIAL HOST INTERFACE OPERATION

Although it is commonly referred to as a standard for computer communications, RS232C was in fact defined and developed for telecommunications systems. There are many different interpretations and implementations in use today as its application to computer systems is not quite compatible with its original purpose.

Users must be very careful to understand exactly how RS232C has been implemented in the equipment they are using. There is no guarantee that two systems, when connected together by RS232C, can communicate.

In its original conception, the RS232C standard was defined as the interface between a remote terminal and a modem connected to a telecommunications channel (see Figure below).

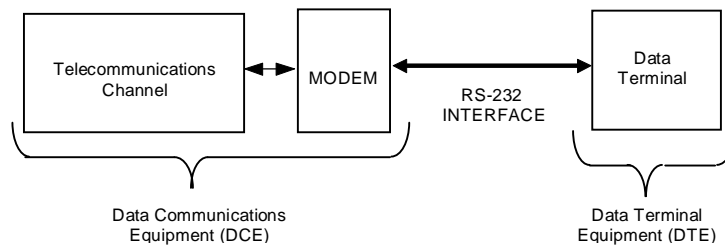

Figure 6-1: RS232C Interface in a Telecommunications System

Since the cable was expected to be a straight pin-to-pin connection, two types of connectors were defined and as DTE (Data Terminal Equipment) and DCE (Data Communications Equipment). Of the 25 lines defined in the official standard and shown in Figure 6-3, only 9 at the very most are ever used on computer interconnects. They are identified in Figure 6-2, below.

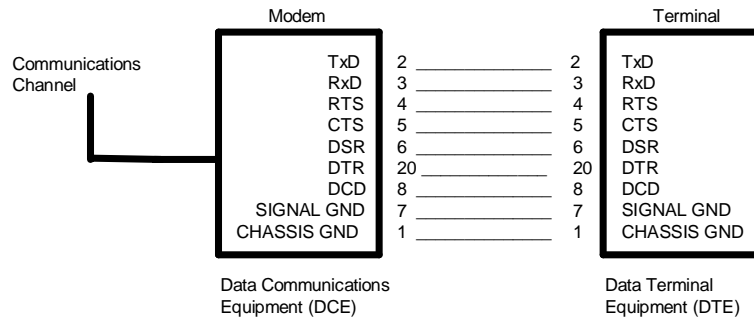

Figure 6-2: RS232C INTERFACE DEFINITION

IN TELECOMMUNICATIONS SHOWING LIMITED SIGNAL SET

There are some basic differences between the original telecommunications hook-up (i.e. computer to modem), and the computer to computer, or computer to terminal situations.

In the case of two computers or terminals, using a two-way data channel (full-duplex), both devices can be assumed to be active all the time, and none of the handshaking signals required for establishing communications links in a single-channel switched telecommunications network are required.

In fact, for the computers and terminals, the only handshaking required is to indicate busy/not busy. This can be done with only two lines, one driven by each device.

This protocol is typically implemented using the RTS/CTS or the DTR/DSR pairs of lines.

The descriptions DTE (Data Terminal Equipment) and DCE (Data Communications Equipment) for the connectors is a carry over from the original specifications. The primary difference between the two in a computer to terminal situation is that they define different pin-outs (e.g. received and transmitted data pins are swapped).

It is important to check the style of connectors before connecting two pieces of equipment together. Deeco terminals always use the DTE style of connection.

DEECO IMPLEMENTATION - FULL DUPLEX

Deeco controller systems implement the RTS/CTS style of the interface. Recommended wiring connections for some different situations are shown in Figure 6-3. Note that the pin numbers shown here are those of the standard RS232C D-Subminiature 25-pin connector. On the Deeco M9ST product, pins 12, 13, 24 and 25 have been used to implement RS 485.

TxD and RxD are the lines assigned for transmission and reception of data. RTS will be asserted* by the controller when the input data buffer is 80% full. This should cause the host to stop sending further data. When the buffer is reduced to 20% of its capacity, the RTS signal will be de-asserted* so that communications from the host can resume.

CTS is an input to the controller which is used to control transmission from the controller to the host. While the CTS line is asserted the data transmission will be inhibited.

* For the purpose of this discussion “asserted” is defined as the state of the signal which will produce a logic “1” (+5V) at the output of the RS232C line receiver. “De-asserted” is the opposite condition (see Figure 6-4).

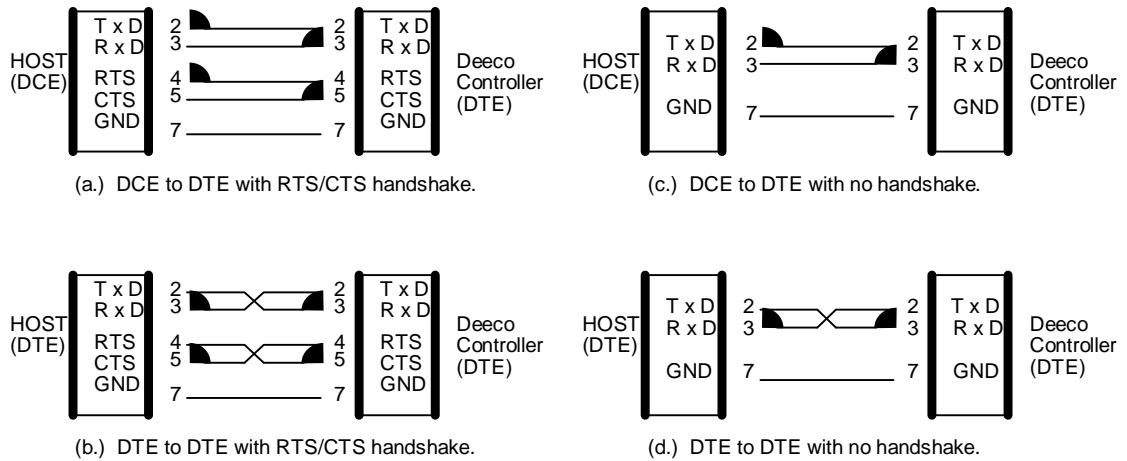

Figure 6-3: Cabling Between a Host System and the Deeco Display Controller

A parallel “busy” protocol is implemented in software. At the same time as the controller sends the “busy” indication on RTS, it also transmits an XOFF (13H) message to the host which is an alternative indication for busy. The return to a ready condition is signaled by the message XON. (11H).

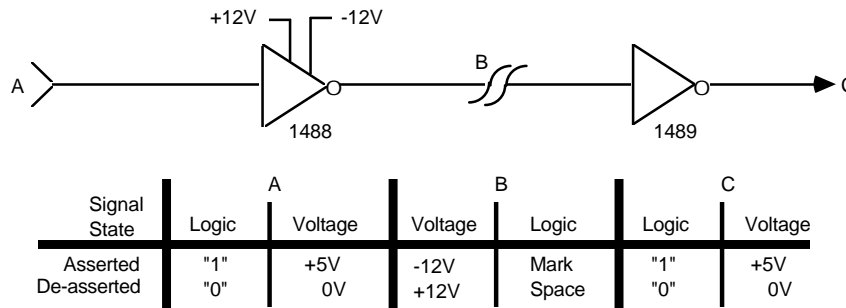

Figure 6-4: Typical RS232C Transmission Line Schematic

INCOMPATIBLE SYSTEMS

Although most computer systems can be set-up to operate in the manner just described, there are many systems which cannot. Their operation more closely resembles that of the original handshake signal definitions and may not be accessible to changes. In those cases the best approach is to connect up only the data lines and, of course, signal ground.

In this case, the software XON/XOFF protocol should be used in conjunction with a lower baud rate (e.g. 9600 or lower). This will indicate to the host when the display controller is “busy.” The other condition, namely the host being overloaded by transmission of data from the controller, is much less likely to occur since there are few cases in which large blocks of data are sent by the controller. When this does occur, it is only at the request of the host. Furthermore, the size of the data blocks can be controlled by the host.

6.1.1 Data Format

The data format is fixed unless the set-up screens are used. It consists of:

9600 Baud

1 Start Bit

8 Data Bits

1 Stop Bit

No parity check is made.

If E9 is installed, it is possible to change the data format with set-up screens.

6.1.2 Handshake Techniques

Both hardware and software protocols can be implemented. The software XON/XOFF protocol is the simplest to implement but it has a limitation: it is less effective than hardware because of the lag time involved in processing the command. This is especially important with higher baud rates (19.2 KB or higher).

6.1.3 RS485 Multi-Drop Communications

One of the inviting features built into Lucas Deeco terminals is the ability to communicate in RS485 multi-drop mode. There are a lot of advantages to RS485 mode, such as continuous distance communications, resistance to noise interference and the ability to network several terminals to one host. This networking capability is commonly referred to as multi-drop mode.

Below is a diagram of the standard wiring.

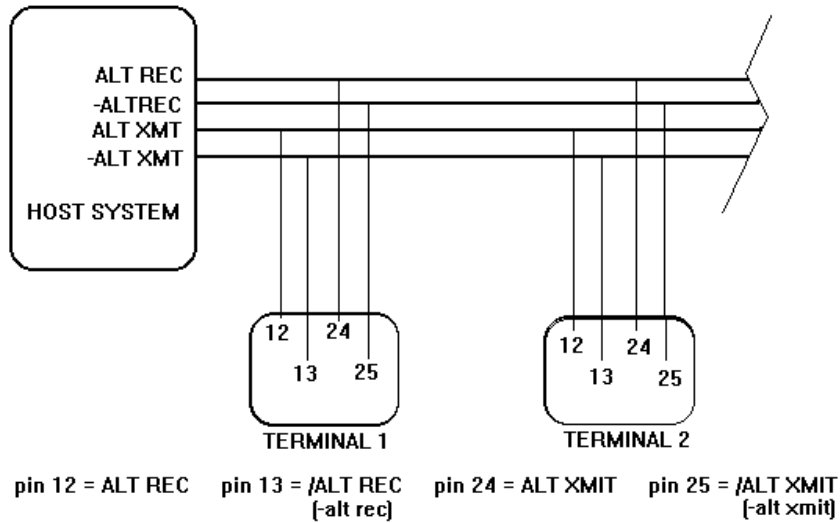

The above drawing shows a multi-drop configuration with an IBM PC as a host and two Lucas Deeco terminals on the line. As many as 30 units can be connected in this configuration. Once the units are properly wired, terminate both ends of the line.

At power up the terminal is always in a non talker and non receiver mode. It needs to be set into the receiver mode by a receive control sequence:

CSI Pi d[or

CSI Pi d| Allow the unit to transmit use the proper transmit control

There are no termination resistors on the Lucas Deeco terminals. The termination should match the characteristic impedance of the transmission line, and is available from the cable manufacturer. If this specification is unavailable, start with 100 ohms at each end, and then experiment to get the best results.

6.1.3.1 RS485 Set-Up Fields

The next step is to select the proper setup configuration on the terminals. Although the set-up screens on the terminals are not universal, the following parameters will still apply. Communications will be set at “485, 2 channel”, “Network on”. You will also need to input the data for “This ID” and “Next ID”. This ID and Next ID control the order of communication on your net. For now we will assign “This ID” as No. 1 and “Next ID” as No. 2 on Terminal 1, and “This ID” as No. 2 and “Next ID as No. 0” on Terminal 2. The host will also have an ID number. This is typically 0. To assign the appropriate ID numbers, please follow these directions:

1. Touch the bottom left corner of the touch screen to bring up the on screen keyboard.
2. Touch the “PAD” key to bring up the number pad keyboard.
3. Touch the “SET-UP” key to bring up the set-up screen.
4. Touch the right arrow key to align the pointer with the “COMMUNICATIONS” menu selection.
5. Touch the down arrow to align the pointer with either the “THIS ID” or “NEXT ID” as desired.
6. Touch the “ENTER” button on the arrow keypad to de-highlight the appropriate ID selection.
7. Touch the bottom left corner of the screen again to bring up the on screen keyboard.
8. Touch the “KEYBOARD” button again to bring up the alphabet keyboard.
9. Using the numbers on the top row of the alphabet keyboard, input the appropriate ID number.
10. Touch the “PAD” button to bring up the number pad keyboard.
11. Touch the “CR” (Carriage Return) button on the number pad keyboard to store ID number.
12. Touch the bottom left corner of the screen to remove the on screen keyboard.
13. Touch the left arrow button to align the pointer with the “GENERAL” menu selection.
14. Touch the down arrow to align the pointer with the “SAVE STATE” selection.
15. Touch the “ENTER” button to save the settings. (The screen will blink at this point.)
16. Touch the “EXIT” key to return back to the ready state on the terminal.

6.1.3.2 RS485 Operations

There are three modes of network communication available to the user. The first is Short Span Transmission, the second is Continuous Span Transmission, and the third is the Receive Control Mode. In all three methods, each unit and the host are assigned an ID number. That is the “This ID No.” discussed earlier. Each unit is also assigned a “Next ID No.”. The “Next ID No.” dictates which unit will have control of the net when the current user is finished. It is the next transmitter to speak.

Short Span Transmission: In short span transmission mode, the host will send out the command “CSI Pid |” Where CSI = “ESC [” or “1B” + “5B” hex, Pid = the ID number of the desired terminal, and | = “7C” hex or “124” ASCII. When short span mode is initiated, the selected transmitter will then output all buffer stored information onto the net. When its buffer is empty, it will relinquish the net to the unit ID number that is programmed into the “Next ID” slot. For instance, referring to our earlier pictured configuration, if the host were to send out “CSI 1 |”, Terminal 1 would transmit all buffer stored information out on to the net. All multi-drop units would ignore this information. The host, of course, would receive and process this information accordingly. After emptying its buffer,

Terminal 1 would then send out the command “CSI 2|”. This would turn control of the net over to Terminal 2. Terminal 2 would then empty out its buffer onto the net. After emptying its buffer, it would then send out

“CSI 0 |”, turning over control of the net to the host. The process would then start over again with the host initiating the short span transmission mode. If there are more than two terminals on the line, this process would continue until all units have responded.

Continuous Span Transmission: In Continuous span transmission mode, the host initiates the transmission mode by sending out the command “CSI Pid }” Where CSI = “ESC [” or “1B” + “5B” hex, Pid = the ID number of the desired terminal and } = “7D” hex or “125” ASCII. The selected transmitter will then empty its buffer stored information onto the net. It will keep control of the net, and output any newly acquired information onto the net until it is overridden by the host.

NOTE: This is the difference between short and continuous span transmission modes. In short span, the selected transmitter will relinquish the net automatically to the programmed next ID when its buffer is empty. In continuous span transmission, the selected transmitter will transmit until it is given an overriding command by the host.

Typically, the host will send out the continuous span transmission again, only this time it will change the ID number to the next desired terminal. It can be any terminal that is on the net, and there is no predetermined order.

Receive Control Mode: When the host sends out the following command “CSI Pid {” the net is now in receive control mode. (CSI = “ESC [” or “1B” + “5B” hex, Pid = the ID number of the desired terminal, and { = “7B” hex or “124” ASCII.) If the ID number is 0, then all terminals on the net will respond to the host output and act accordingly. If the ID number is for a selected terminal, then only the designated terminal will respond.

When networking is enabled on the terminals, all hardware and software handshaking will be turned off. This is by design so the terminals will not interfere with the host for control of the net.

6.1.3.3 Host Commands

RECEIVE CONTROL: CSI Pid {
 Function: Pid = 0: All terminals receive. Pid = 1-30: Only terminal Pid receives.

TRANSMIT CONTROL, CONTINUOUS: CSI Pid }
 Function: Pid: Terminal Pid is the designated continuous transmitter.

TRANSMIT CONTROL, SHORT-SPAN: CSI Pid |
 Function: Pid: Terminal Pid is the designated short-span transmitter.
 This command enables or disables multidrop altogether, and defines the multidrop ID and next ID.

CSI < Penb; Pid; Pnxtid @

where

Penb = 0 disables multidrop
 1 enables multidrop

Pid is the Multidrop ID for the device

Pnxtid is the ID of the device to be used in the short-span termination sequence.

Where M9ST set-up mode is unusable, the multidrop enable command can be used to initialize the terminal to use multidrop. This initialization may be done at power up by embedding the command in display list #0 and enabling the auto-execute of list #0 power-up mode. Refer to section 4 for details.

6.1.3.4 Internal Baud Rate

Baud rates are selected by jumper or by the set-up screens. Refer to section 4 for details.

Keypad Legend	ANSI Sequence
up arrow	CSI A
dn arrow	CSI B
lf arrow	CSI C
rt arrow	CSI D
F1	CSI = Ps a
F2	CSI = Ps b
F3	CSI = Ps c
F4	CSI = Ps d
F5	CSI = Ps e
F6	CSI = Ps f
F7	CSI = Ps g
F8	CSI = Ps h
F9	CSI = Ps i
F10	CSI = Ps j
F11	CSI = Ps k
F12	CSI = Ps l
Insert	CSI = Ps p
Home	CSI = Ps q
Page Up	CSI = Ps r
Delete	CSI = Ps s
End	CSI = Ps t
Page Down	CSI = Ps u

Table 6-1 Keypad Legend (Num Lock On)

Keypad Legend	ANSI Sequence
CSI = P/	CSI = Ps K
*	CSI = Ps L
-	CSI = Ps M
.	CSI = Ps N
Enter	CSI = Ps O
9	CSI = Ps J
8	CSI = Ps I
7	CSI = Ps H
6	CSI = Ps G
5	s F
4	CSI = Ps E
3	CSI = Ps D
2	CSI = Ps C
1	CSI = Ps B
0	CSI = Ps A

Table 6-2 Keypad Legend (Num Lock Off)

The key pad will send the ASCII code corresponding to the character on the key's legend when Num Lock is on. When Num Lock is off the ASCII code corresponding to the key's legend indicated in Table 6.2 will be sent.

The parameter Ps in Tables 6-1 and 6-2 is a bit-encoded number describing the current state of the shift keys SHIFT, CTRL, and ALT. If Ps is missing then it is assumed to be zero (0). The relation between Ps and the shift keys is as follows:

Ps	SHIFT	CTRL	ALT
0	no	no	no
1	yes	no	no
2	no	yes	no
3	yes	yes	no
4	no	no	yes
5	yes	no	yes
6	no	yes	yes
7	yes	yes	yes

Table 6-3 Shift Key Parameter Legend

7.0 Troubleshooting and Repair

Refer also to section 2.7, troubleshooting a new unit.

We believe it is most economical to use the factory's repair service, but we do recognize some customer may prefer to attempt field repairs. These are the basic requirements for field repair:

- 1) A qualified and experienced electronic technician. People without the proper training are likely to make a problem worse!
- 2) An ESD controlled work area. Static electricity introduced into the electronics is often not immediately fatal, but can cause future reliability problems.
- 3) Access to replacement parts.
- 4) A method of driving the computer, monitor, or terminal during diagnostics and repair. Can the same fixture be used for an extended time to assure the repair is complete?

Observe Static Precautions Whenever Handling the M9ST!

ESD damage is not often immediately fatal, but can result in unreliable operation and troublesome repeated failures later in the life of the terminal.

Disconnect Power Before Servicing the M9ST!

Fuse Replacement:

There is a fuse on the power supply. It can be removed and checked with an ohmmeter. Replace it only with the exact type, to avoid a fire hazard.

Oftentimes unreliable operation results if replacement fuse values are not matched exactly. If the fuse is a slow blow type, replace only with a slow blow type fuse. If the fuse is a fast blow type, replace only with a fast blow type fuse, etc.

Cabling and EMI:

If you are experiencing erratic and unreliable operation, consider whether external cables could be picking up electrical noise. If possible, use a shorter external cable as a temporary diagnostic tool. Or, perhaps a shielded cable will help.

Consider routing cables away from sources of electrical noise. Although for mechanical reasons it is tempting to bundle cables together in long parallel runs, this will cause cross-talk between the cables. If you are experiencing glitches, lay out your wiring harness so cables cross at right angles, and avoid parallel runs.

Grounding:

Ground noise can be a troublesome source of unreliable operation in some systems. Pay attention to grounding your systems as well as you can! Usually a star ground topology is preferred - where all the grounds in a system come together at a common point.

The differential mode on an oscilloscope will show ground noise between different parts of the system, and aid in diagnostics.

Virus Detection:

Erratic and troublesome failures can be caused by a virus infection. Run a virus detection software program on your PC if you are having problems. It is essential that virus detection software be current to be effective. Virus problems occur only on the host. The M9ST is immune to virus problems.

Connectors:

If a breakdown occurs after long service in a corrosive environment, it is sometimes worthwhile to check the connectors in the system. Simply removing and re-seating the connectors is sometimes effective. Use extreme care to assure all connectors are replaced exactly as originally installed. More harm comes from misplaced connectors than most other failures!

Contacting the Factory:

Contact information is located inside the cover, at the front of this manual. Also, read the Limited Warranty located near the end of this manual for shipping information.

Lucas Deeco maintains a complete repair facility, stocked with all the replacement parts necessary to fully repair failed products. Special testing and burn-in equipment assure repaired units are fully functional before they are returned to customers.

In most circumstances customers prefer to return failed units to the factory for service.

It is essential customers contact the factory before returning any unit, and obtain a RMA (return unit authorization) number. Freight to the factory is prepaid by the customer. Freight return to the customer is paid by Deeco. **Ship the product in its original packaging or equivalent to prevent transit damage!**

Repair Information Request

RMA # _____ Model # _____ Serial # _____ Date _____

- 1) When did you discover the problem, and how was the problem found?

- 2) How long was the unit in service before the failure occurred?

- 3) What failure indications are visible on the display?

- 4) Are there any mechanical problems associated with the failure?

- 5) Has the unit received any upgrades since the original date of manufacture?

- 6) Who should we contact if we have technical questions during the repair cycle?

Name: _____

Telephone: _____

Primary Customer Contact: Lois Powers
510-476-2526 (Direct Telephone)
510-471-4700 (Factory Telephone)
510-489-3500 (Fax)
powersl@lihaywal.li.co.uk

Pin-pointing failures to the Deeco component often seems obvious, yet "No-Problem-Found" is one of our largest failure categories. In some cases an Application Engineer may be able to suggest field tests that could shorten (or even eliminate) the repair cycle. Application Engineering Hotline: 510-476-2551. The email address is ldtechsupport@compuserve.com.

It is now possible for customers to send "Not to Exceed" purchase orders with out-of-warranty repairs. Products are repaired more quickly than otherwise possible, because the waiting period for a purchase order is eliminated.

Please Include a Copy of this Form With the Returned Unit

Appendix A: Mechanical Drawings

A.1 JUMPER AND CONNECTOR LOCATION

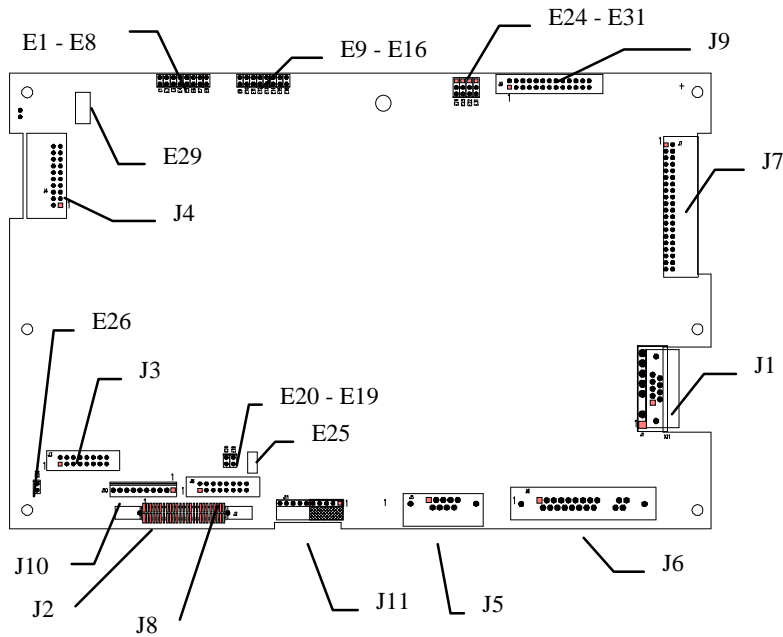

- | | | | |
|----|-------------------|-----|-------------------|
| J1 | Power Connector | J7 | Touch Interface |
| J2 | Display Interface | J8 | Display Interface |
| J3 | VGA Video | J9 | Parallel Port |
| J4 | Touch Interface | J10 | Backlight Power |
| J5 | Printer Port | J11 | External Keyboard |
| J6 | Host Serial Port | | |

A.2 PROPORTIONAL FRONT VIEW

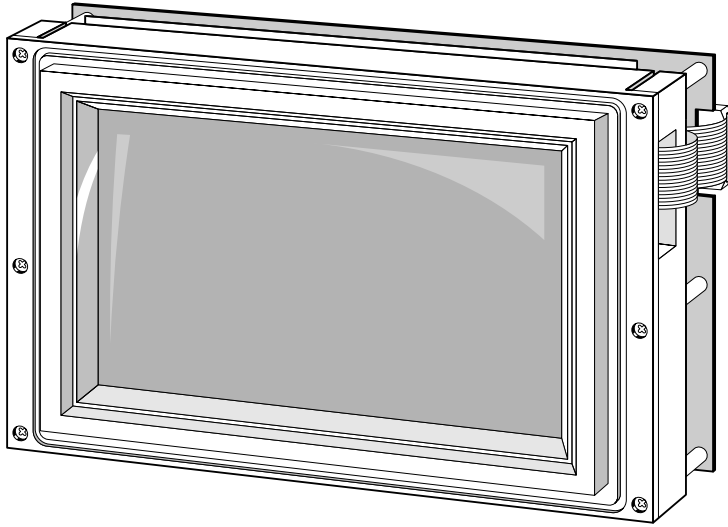

Drawing not to scale.

A.3 BEZEL MOUNTING EXPLODED DRAWING

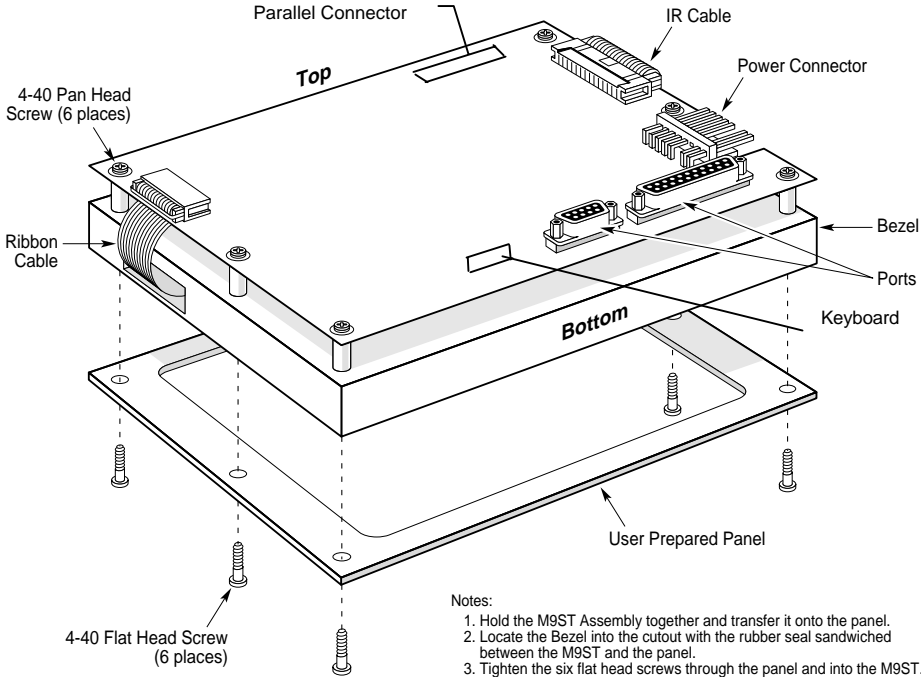

Drawing not to scale.

A.4 FRONT VIEW DRAWING

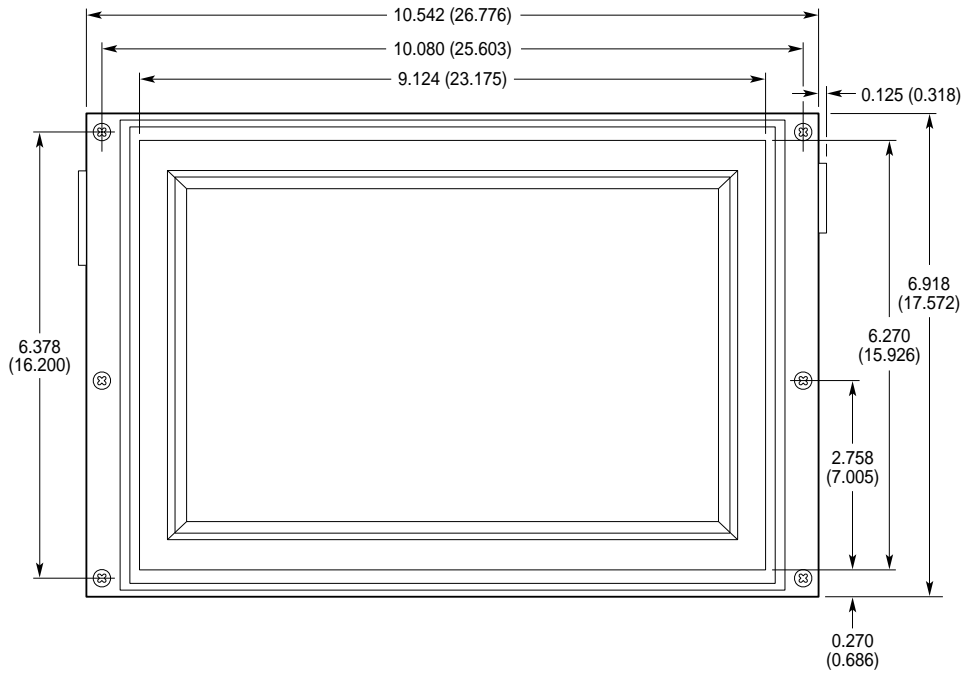

Drawing not to scale -- Dimensions are in inches (cm)

A.5 SIDE VIEW DRAWING

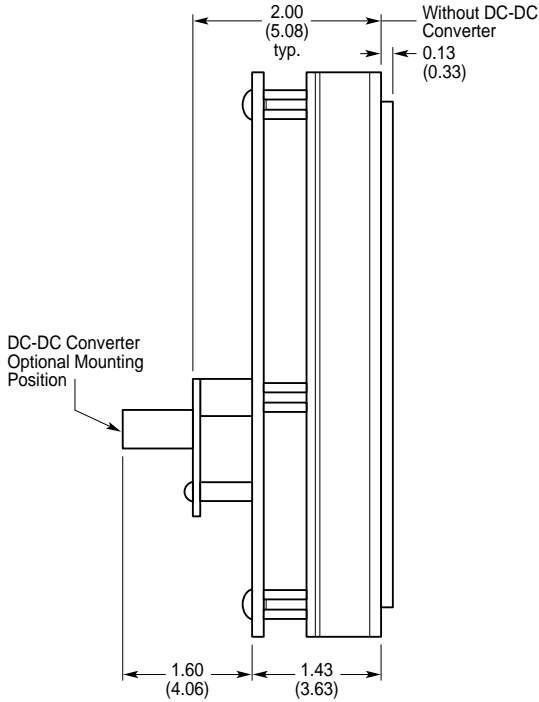

Drawing not to scale -- Dimensions are in inches (cm)

A.6 CUTOUT DRAWING

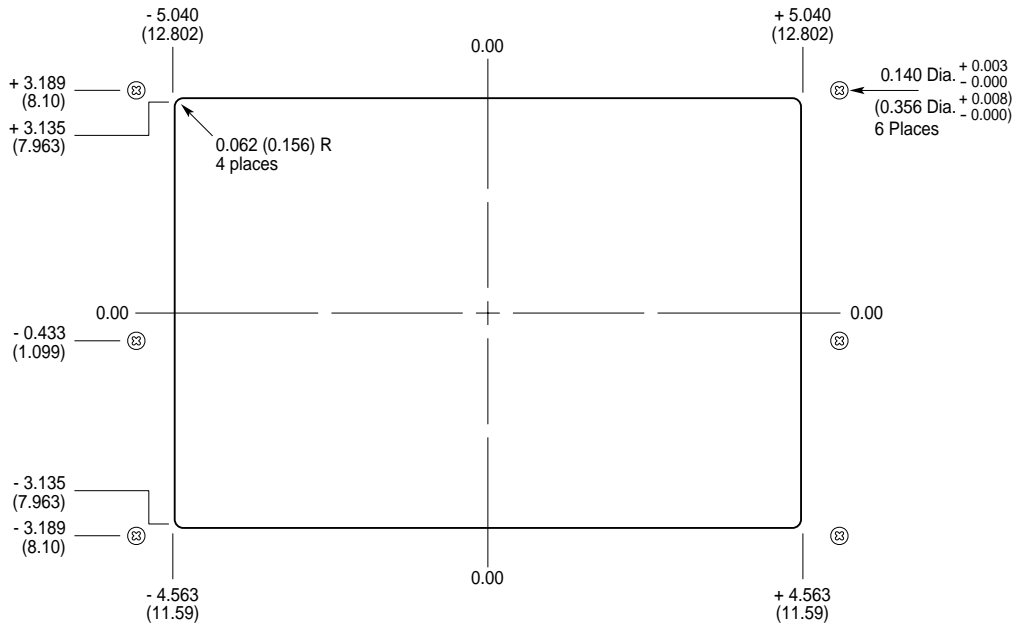

Drawing not to scale -- Dimensions are in inches (cm).

A.7 EMI FRONT PANEL CUTOUT

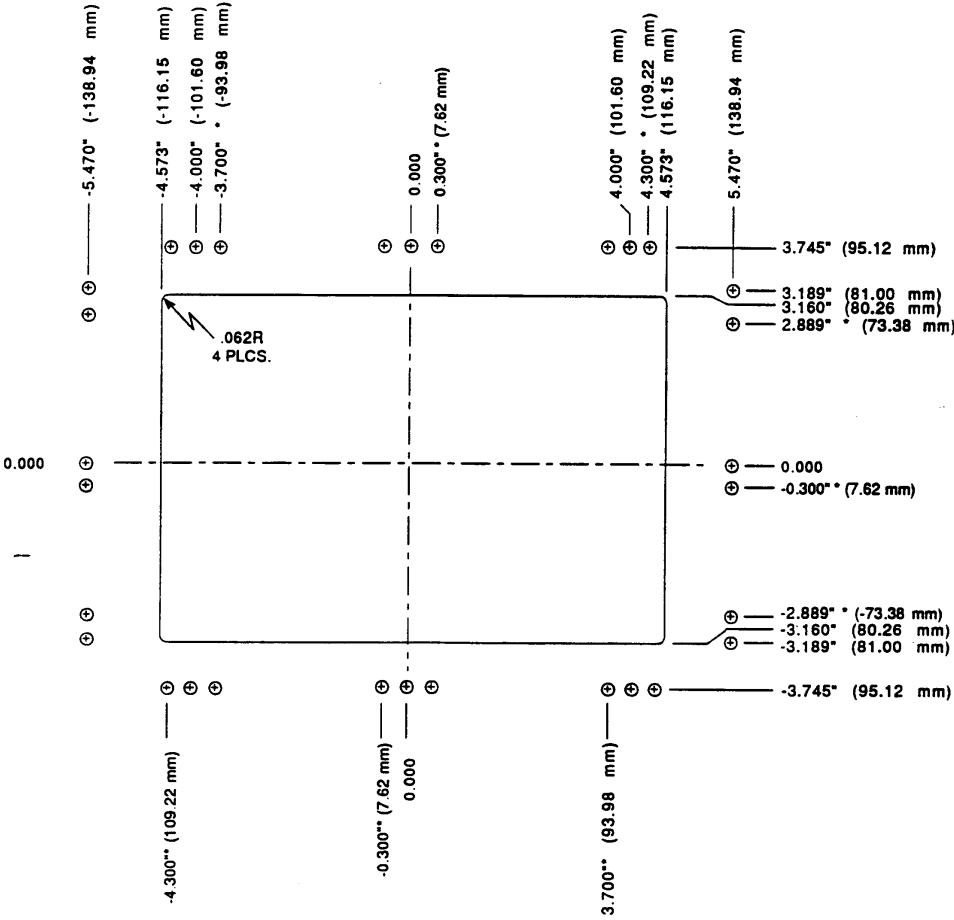

* Optional Mounting Holes

A.8 EMI FRONT PANEL

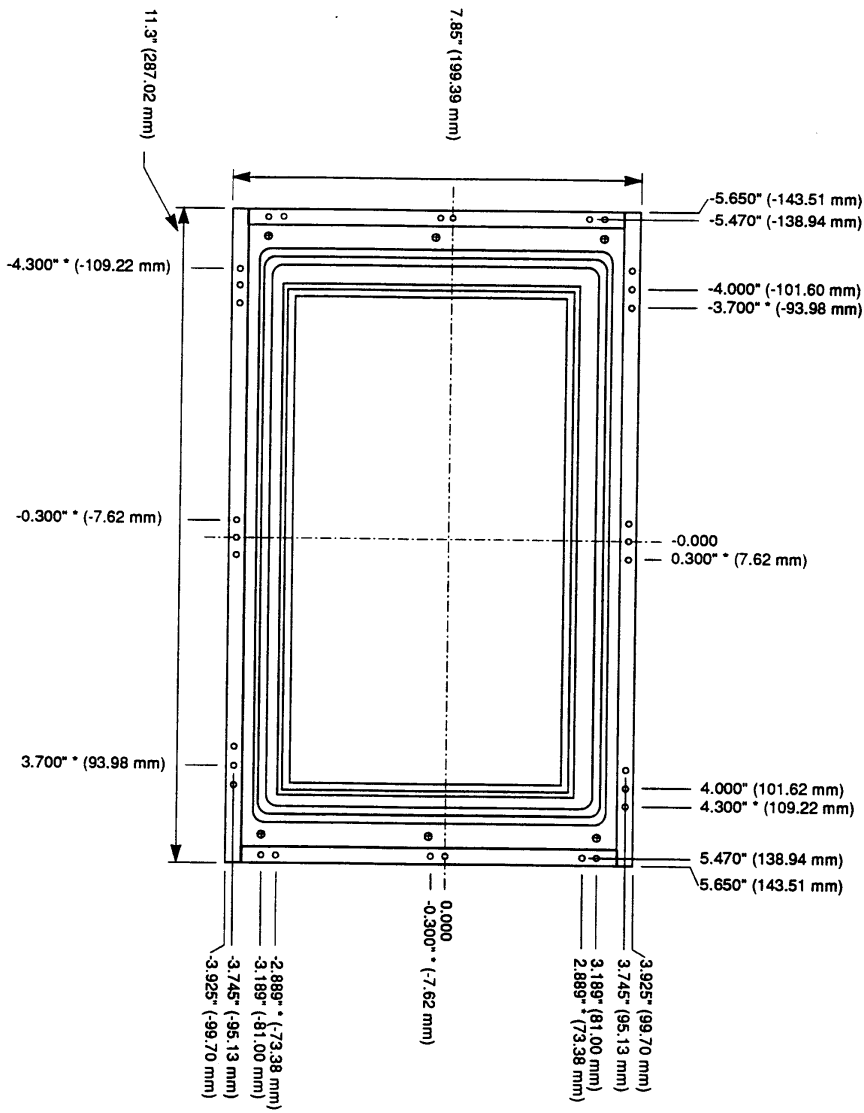

* Optional Mounting Holes
8-32 THD Thru

A.9 EMI SIDE VIEW

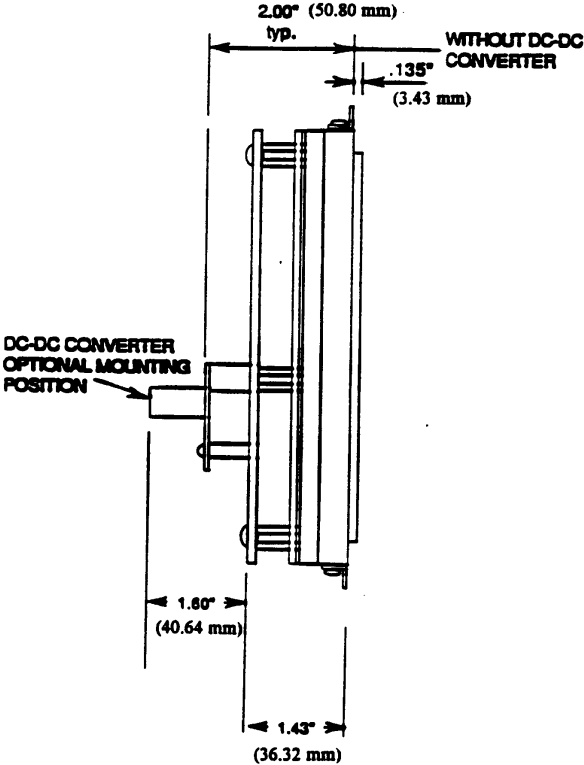

Appendix B: Ordering/Customer Support

B.1 ORDERING

This information will be requested when placing an order:

- Company Name
- Complete Billing Address
- Ship To Address
- Purchase Order Number
- Buyer's Name
- Buyer's Telephone Number
- Technical Contact's Name (for product update information)
- Technical Contact's Telephone Number
- Method of Shipment
- Whether order is resale or not (if order placed for California company)
- Product Order
- Quantity of Product Order

B.2 CUSTOMER SUPPORT

Lucas Control Systems places great importance on building and maintaining excellent customer relations. Customer feedback and communication are invaluable tools in providing the best possible products and services.

Should you require operational assistance, or have other questions relative to the M9ST, our Technical Support personnel are trained to provide technical assistance by calling, (510) 471-4700, Monday through Friday, from 8:00 A.M. 5:00 P.M. Pacific Time.

For assistance in Europe call 49-7024-971214.

Appendix C: Product Naming Convention

ST - C 4 6 1

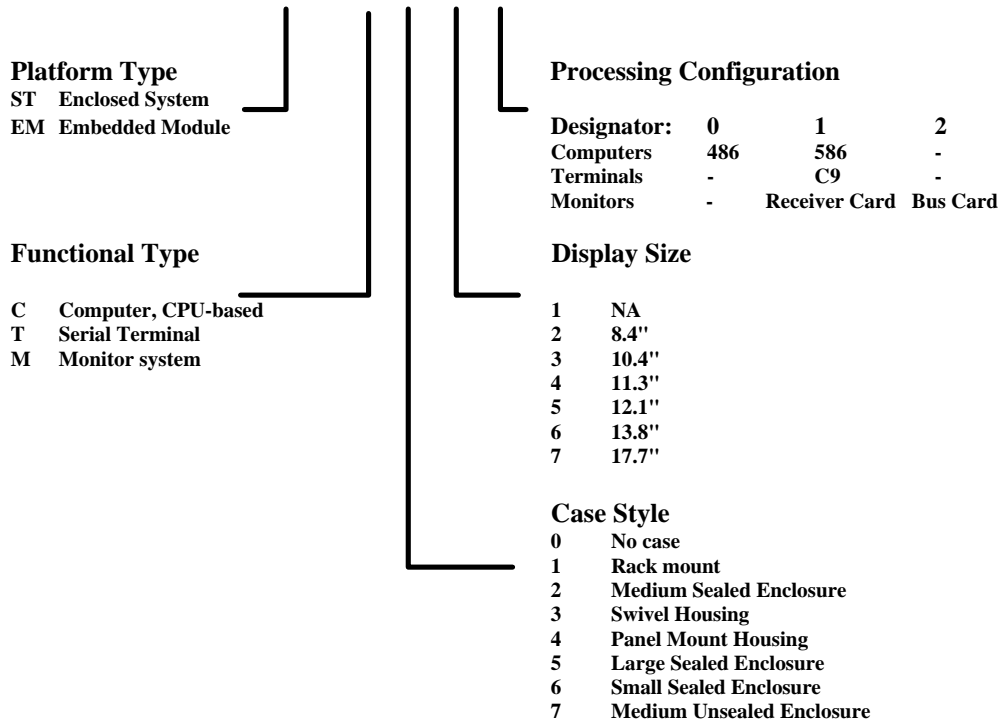

Examples

ST-C461 Sealed Computer, Medium case, 13.8" display, Pentium SBC
 EM-C031 Embedded computer, 10.4" display, Pentium SBC

Newer products are named according to the system described above. The M9ST was named prior to adoption of this system.

Appendix D: Additional Documentation

These publications may be of interest to the designer and user:

C4 Serial Terminal Firmware User Manual (P/N: 15981)
(Contains information vital to the operation of the M9ST)
(Includes a Frequently Asked Questions section)

Application Note 003971:
"General Functional Overview: Deeco Serial Touchscreen Displays (C9)

Application Note 181971: "C9 Quick Mode"

Application Note 080971:
"Serial Communications Cable with Hardware Handshaking (RS-232)"

Application Note 192971: "Quick Start Guide to Touch Buttons"
(Wholly reprinted in C4 Firmware User Manual, partially reprinted in this manual)

Limited Warranty

Lucas Control Systems, Deeco warrants this product against defects in materials and workmanship for a period of one year from the date of original shipment from the factory.

During this warranty period, Lucas Control Systems will, at no cost to the buyer, promptly repair or replace defective equipment returned to the factory, or other authorized warranty repair center, transportation charges pre-paid by the buyer, and will return such equipment, transportation charges prepaid. Lucas Control Systems' sole obligation shall be, at its option, to repair or replace any goods which have been determined to be defective by Lucas Control Systems.

Equipment returned to the factory must be accompanied by the following information:

- Returned Material Authorization (RMA) number, obtained from Lucas Control Systems;
- Reason for return, with a comprehensive description of the malfunction;
- The name and telephone number of the person to contact in the event of questions or problems; and,
- Shipping instructions

This warranty shall not apply to damage resulting from improper handling, accident, negligence, loss or damage in transit, or abuse (such as applying the wrong polarity or voltage power). This warranty shall be voided should the buyer attempt any repairs or alterations without prior written permission of Lucas Control Systems.

Lucas Control Systems makes no other warranty, either expressed or implied, and disclaims any warranty or merchantability or fitness for a particular purpose. Any action by buyer for any alleged breach of this warranty shall be brought to the attention of Lucas Control Systems by the buyer within the warranty period.

Repairs and/or replacement under the terms of this warranty **SHALL NOT EXTEND THE WARRANTY LIFE OF THE ORIGINAL EQUIPMENT SUPPLIED.**

LIMITATIONS OF LIABILITY

THE BUYER AND LUCAS CONTROL SYSTEMS AGREE THAT THE SOLE AND EXCLUSIVE REMEDIES FOR BREACH OF ANY WARRANTY SHALL BE REPAIR OR REPLACEMENT OF DEFECTIVE PARTS ACCORDING TO THE TERMS DESCRIBED ABOVE. LUCAS CONTROL SYSTEMS SHALL NOT BE LIABLE FOR CONTINGENT OR CONSEQUENTIAL DAMAGES TO PERSONS OR PROPERTY, AND LUCAS CONTROL SYSTEMS' SOLE LIABILITY IS AS SET FORTH ABOVE. THIS STATEMENT OF WARRANTY AND LIMITATION OF LIABILITY IS A COMPLETE AND EXCLUSIVE STATEMENT OF ALL WARRANTY AND LIABILITY REPRESENTATIONS OF LUCAS CONTROL SYSTEMS.

IT MAY NOT BE VARIED, SUPPLEMENTED, QUALIFIED OR INTERPRETED BY ANY PRIOR DEALINGS BETWEEN THE PARTIES OR BY ANY USAGE OF THE TRADE OR UPON THE FACE OR REVERSE OF ANY FORM TO WHICH THIS IS ATTACHED OR PART OF, NOR MAY IT BE MODIFIED BY ANY AGENT, EMPLOYEE, OR REPRESENTATIVE OF LUCAS CONTROL SYSTEMS.

Index

—A—

AC, 25
 ANSI, 23, 30, 56, 57
 Application Notes, 77
 Applications Engineering, 3, 6, 61
 Aux Memory, 36
 Aux Memory Jumper Selection, 36

—B—

Bad Beam, 39
 Baud rate, 26, 33, 34, 41, 50
 Baud rates, internal, 55
 BIOS, 18
 Button beep mode, 42
 Button enter mode, 42

—C—

Cabling, 18, 49, 60
 Cleaning, 44
 COM1, 18, 20
 COM2, 20
 Computer, 11, 13, 18, 19, 38, 47, 48, 50, 59
 Configuration, 1, 2, 11, 14, 18, 33, 52, 53, 75
 Configuration by State Memory, 11
 Connector, 11, 18, 19, 28, 29, 30, 49
 Contacting the Factory, 3, 60
 Control codes, 13
 CSI, 20, 24, 52, 53, 54, 55, 56, 57
 Current, max draw, 7
 Cursor, 40
 Customer Service, 3

—D—

Data Bits, 42
 Data Format, 26
 DCE, 47, 48
 DCS, 20
 DEC Computer, 13

Diagnostics, 10, 59, 60
 Display, 9, 10, 14, 18, 19, 21, 27, 30, 33, 35, 36,
 37, 38, 39, 40, 49, 50, 55, 61, 63
 DOS, 13, 19, 20, 22, 23
 DTE, 47, 48

—E—

EMI, 60
 EMI Drawings, 69, 70, 71
 EMI shield, 6
 Emulation, 39
 ESC, 20, 21, 22, 23, 24, 53, 54

—F—

Features, 18, 39, 51
 Form Feed, 40
 Full Duplex, 35, 49
 Fuse, 59

—G—

Graphics, 13
 Grounding, i, 60

—H—

Half Duplex, 35
 Handshaking, 13, 51
 Host, 34, 40, 49
 Host Commands, 55
 HOST PC Serial Software, 11, 18, 19, 20, 21, 22,
 23, 25, 40, 47

—I—

I/O, 42
 Incompatible Systems, 50
 Input, 18, 27, 28, 29, 37, 42, 43, 49, 53
 Input Voltage, 7
 Input/Output Interface Ports, 27
 Installation, 5

Interface, 9, 26, 27, 30, 47, 49

—K—

Keyboard, 13, 14, 15, 20, 21, 23, 25, 26, 27, 30, 38, 39, 41, 43, 53, 63

—M—

Maintenance, 44
Mapping, 41
Mechanical, 60, 61, 63
Mechanical Integration, 6
Memory, 10, 11, 24, 33, 34, 35, 36
Menus, 16, 19, 20, 23, 25, 26, 38, 39, 43, 53
Modem, 11, 25, 29, 47, 48
Mounting, 6
Mouse, 18, 19

—N—

Networking, 41
New Line, 41
Next Line, 40
Non-Volatile, 35

—O—

Options, 2
Output, 18, 27, 28, 29, 49, 53, 54

—P—

Panel Mount Computer, 1
Parallel Port, 42
Parity, 42
PC Serial Communications Software Selection, 18
Pigtail, 5, 8
POWER, 8, 10, 11, 17, 25, 26, 33, 37, 52, 55, 59, 79
Power Supply Options, 2
Power-up Mode, 37
Print Screen, 38, 40
Printer, 27, 40, 63

—Q—

QWERTY Keyboard, 14, 20

—R—

RAM, 10
Receive Control Mode, 53, 54
Reliability, i, 59
Repair, 59, 60, 61, 79
Report, 10, 43
Returns, 3
RS232, 11, 12, 13, 29, 30, 34, 42
RS232C, 42
RS422, 11, 26, 29, 34, 42
RS485, 11, 26, 29, 34, 35, 41, 42, 51, 53
RS485 Configuration, 35

—S—

Screen Saver, 40
Sealed, 1
Sequence Introducers, 20
Serial Communications Port, 28
Serial Mode, 34
SetUp, 15, 16, 17, 19, 20
Set-up Menus, 38
Shock, i
Software, 2, 11, 13, 18, 24, 43, 50, 51, 54, 60
Specifications, 1, 3, 48
Standalone Computers, 1
Stop Bits, 42

—T—

Testing the Touch System:, 17
Touch, 10, 14, 17, 18, 19, 20, 21, 22, 23, 24, 25, 38, 42, 43, 44, 53
Touch Assist, 1
Touch resolution, 43
Touch Screen, 14, 17, 25, 44, 53
Troubleshooting, 59

—U—

Unpacking, 5

—V—

VGA, 39
Video, 23, 24, 41
Viewports, 39
Virus, 60

Voltage, 7, 25, 29, 79

Windows, 18, 25

—W—

—X—

Warranty, 60, 61, 79

XON/XOFF, 13, 42, 50, 51